

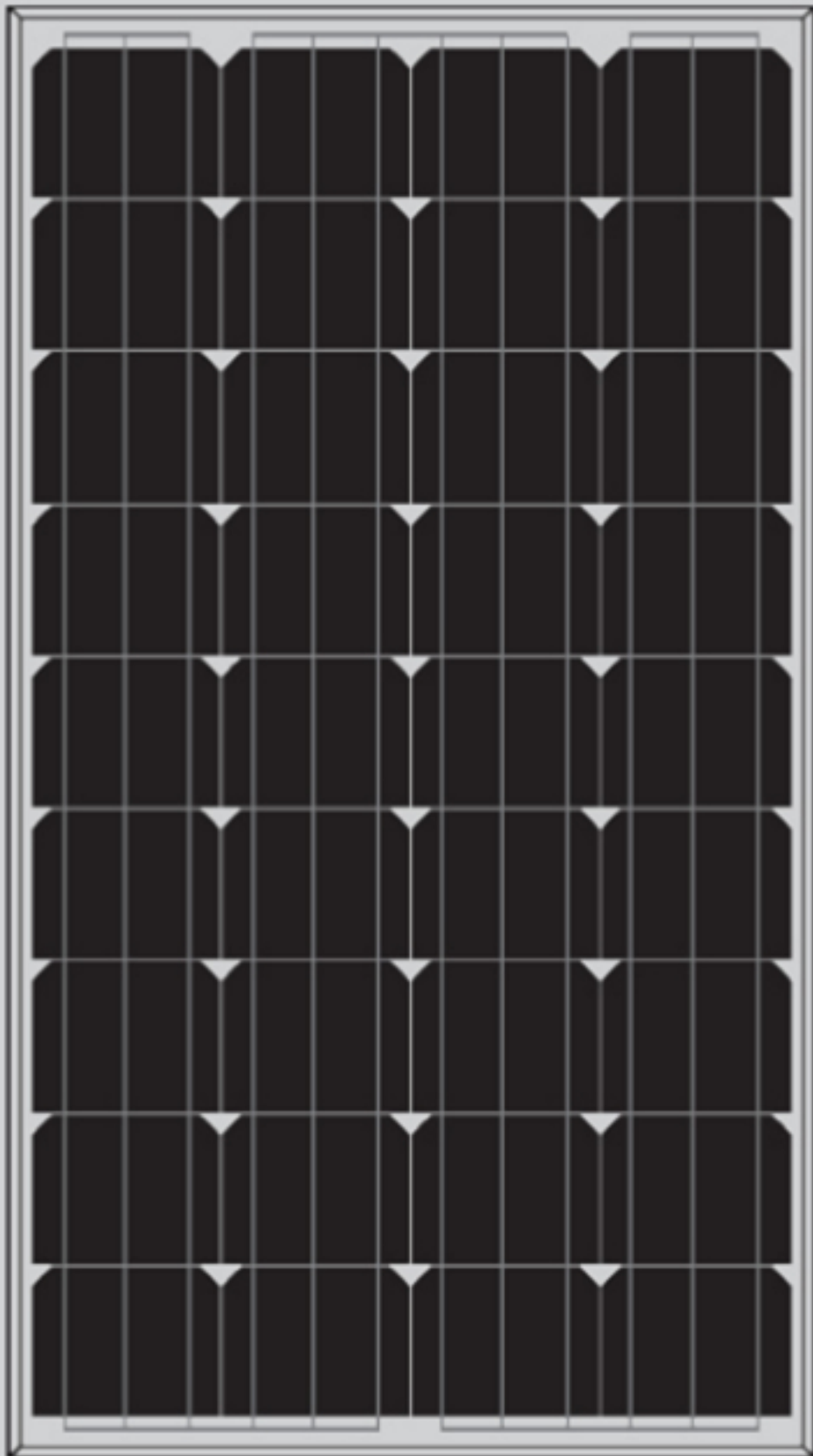

GP-120 GP-125

MONOCRYSTALLINE SILICON MODULE



Products Characteristics



Widely using of the most popular and mature type of modules for off-grid system.



Leading manufacturing technology in PV industry, strictly controlling the quality of raw materials and the process of producing



100% EL inspection, ensures modules are defects free.



Cells binned by current to improve module performance



Anti reflective glass. Not only to increase the light absorption, but also to make the module has the function of self-cleaning in water environment, effectively reducing the power loss caused by dust.



Outstanding performance in low-light irradiance environments.



Excellent mechanical load resistance: Certified to withstand high wind loads(2400pa) and snow loads(5400pa).



High salt and ammonia resistance



Positive power tolerance: 0~+5w

Warranty

- 5 years product warranty
- 10-years 90% of Min. rated output power, and 25-years 80% of Min. rated output power warranty

GP-120 GP-125



GREENERGY POWER
SOLAR TECHNOLOGY

Engineering Drawings (Front Side)

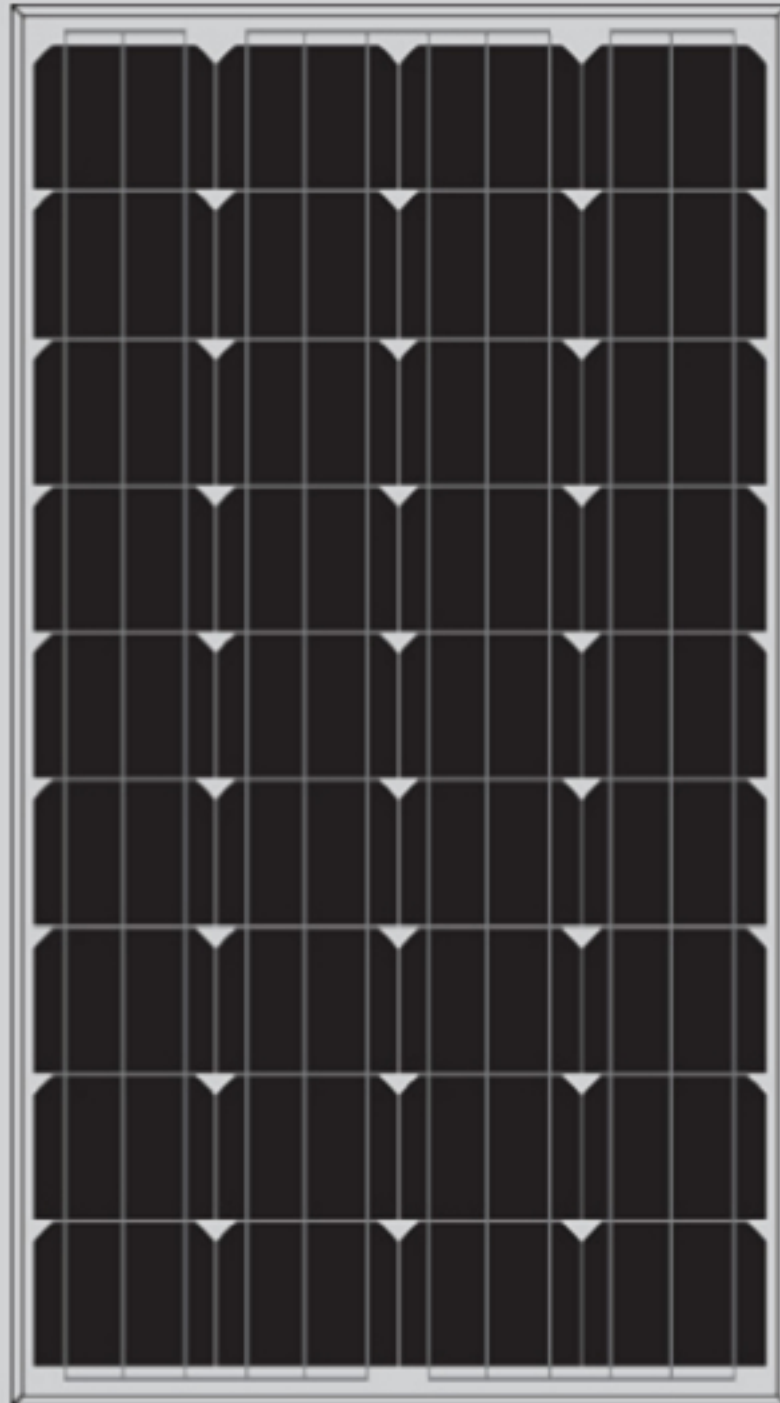

Engineering Drawings (Back Side)

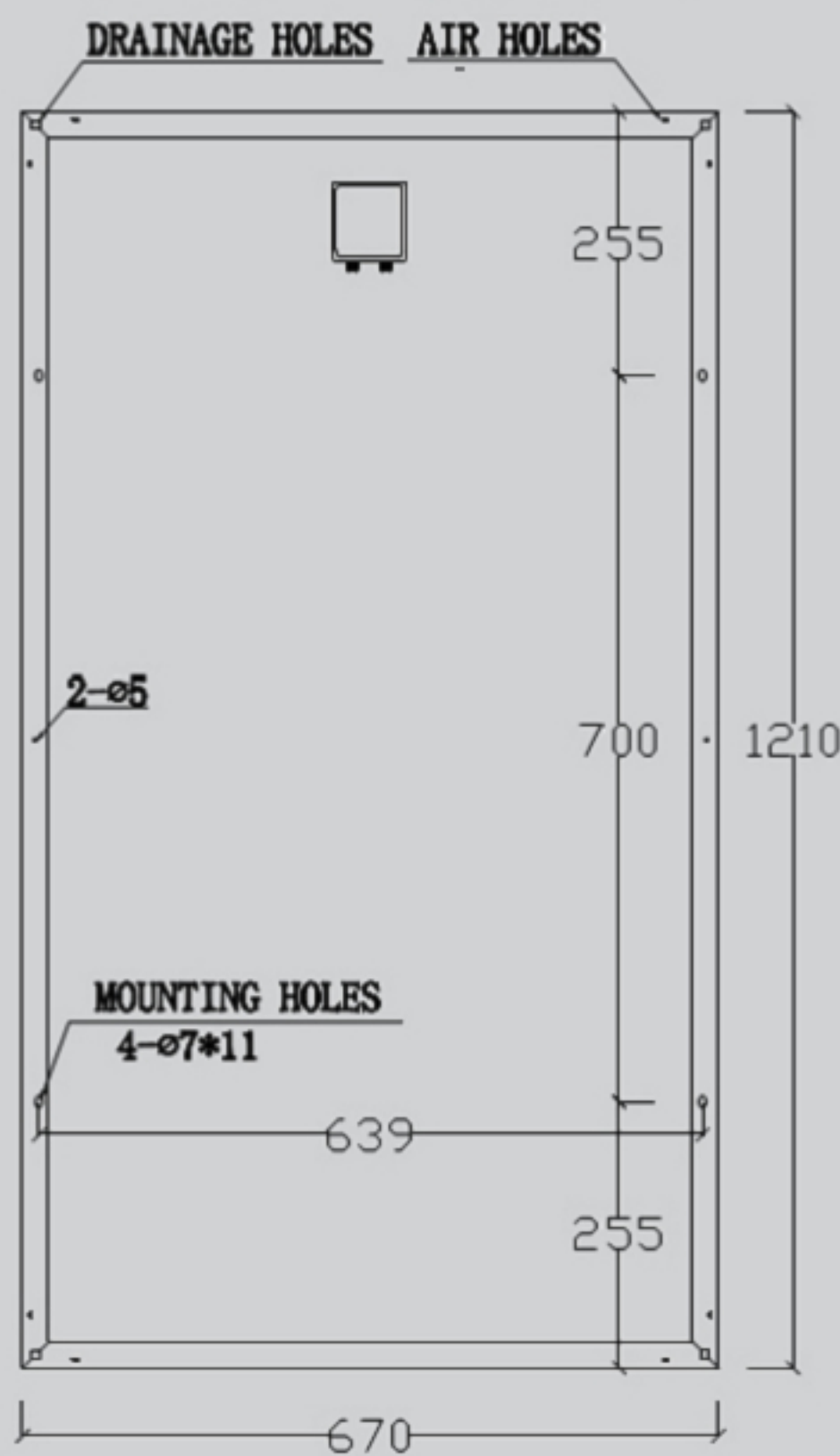

Raw materials and Mechanical Parameters

	GP-120	GP-125
Type of Cells(mm)	mono156 × 124.8	
NO. of Cells and Connections	4 × 9=36	
Dimensions(mm)(L*W*H)	1210 × 670 × 30	
Weight(kg)	9.0	
Glass	3.2mm Tempered Glass	
Encapsulation	EVA	
Backsheet	Multilayer Composite	
Aluminium-Frame	Silvery/Black Anodized aluminium alloy	
Junction-Box	IP65/IP67	
Cable	NA, but customized is acceptable	
Connector	NA, but MC4 and MC4 Compatible are acceptable	
Package Configuration	4pcs/ctn	

Performance Parameters

	GP-120	GP-125
Maximum System Voltage	700V	
Operating Temperature	-45~+80°C	
Maximum Series Fuse	10A	
Maximum Static Load, Front Side (e.x. Snow, Wind)	5400Pa	
Maximum Static Load, Back Side (e.x. Wind)	2400Pa	
Application Grade	Class A	

Electrical Parameters (Standard Test Condition)

	GP-120	GP-125
Rated Maximum Power(Mp)	120W	125W
Power Tolerance	0~ +5W	
Cell Efficiency	17.6%	18.4%
Open Circuit Voltage(Voc)	22.4V	22.6V
Maximum Power Voltage(Vmp)	17.6V	17.8V
Short Circuit Current(Isc)	7.09A	7.43A
Maximum Power Current(Imp)	6.82A	7.02A
Temperature Coefficient of Isc	+0.06%	
Temperature Coefficient of Voc	-0.32%	
Temperature Coefficient of Pmp	-0.45%	
Standard Test Condition	Irradiance:1000W/M2, Cell Temperature:25°C, Spectrum AM:1.5	

The Electrical Parameters of the module are the average theory figure under the standard test condition, each one exists difference. Can not be treated as the basis of module delivery.