

70~115 Watt

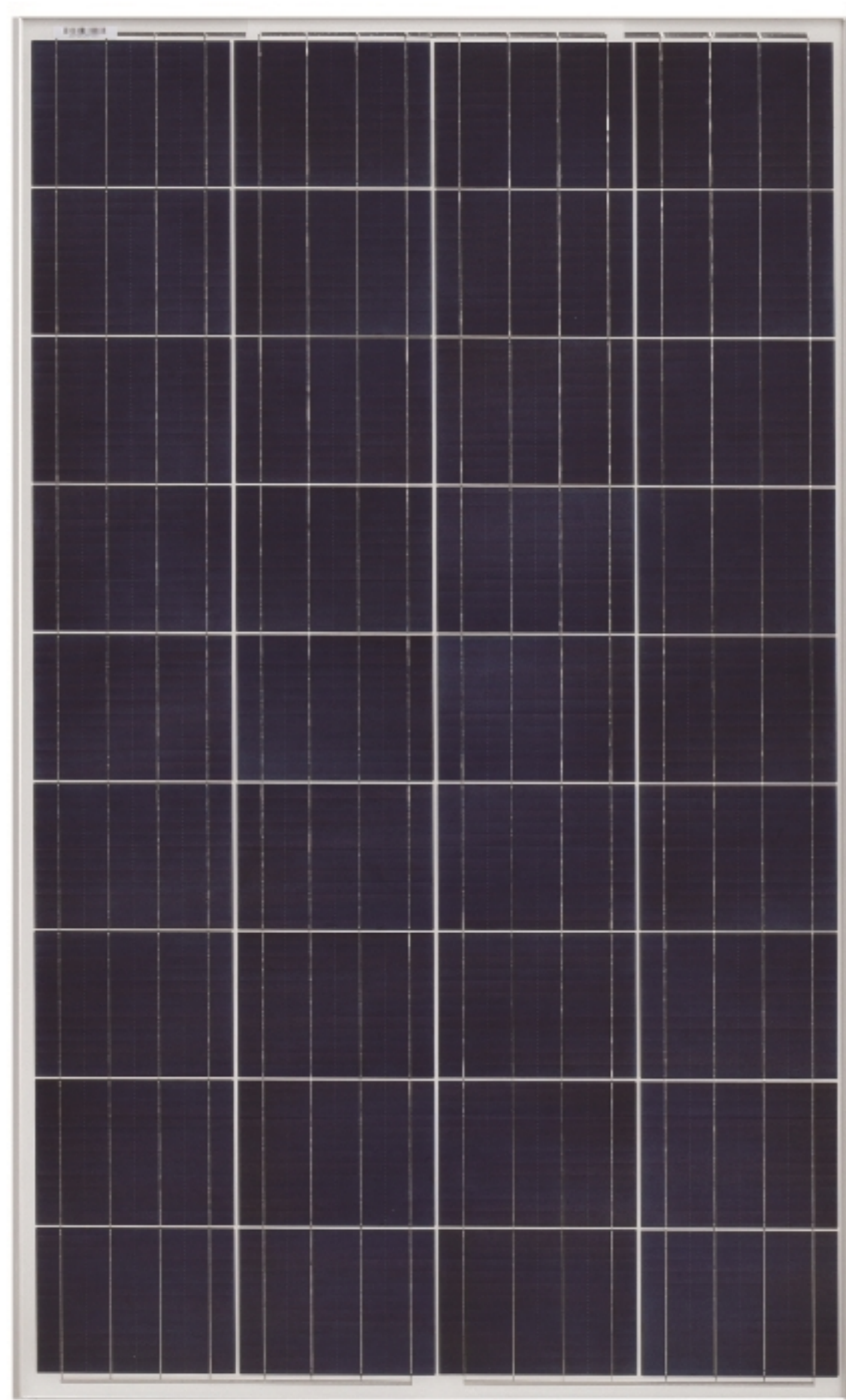

*BLACK FRAME/BLACK BACK-SHEET PRODUCTS ARE AVAILABLE UPON REQUEST



110W-115W

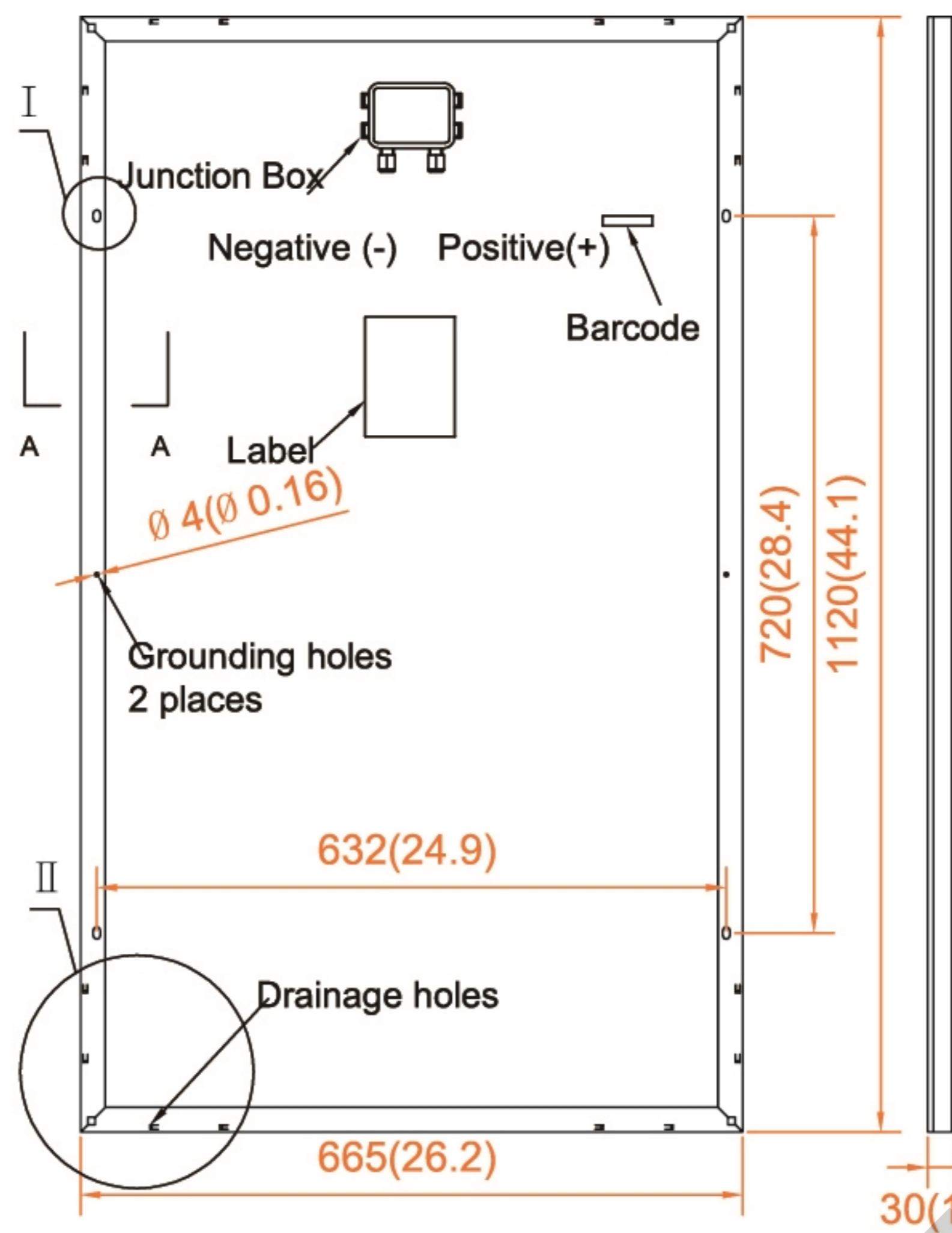

95W-105W

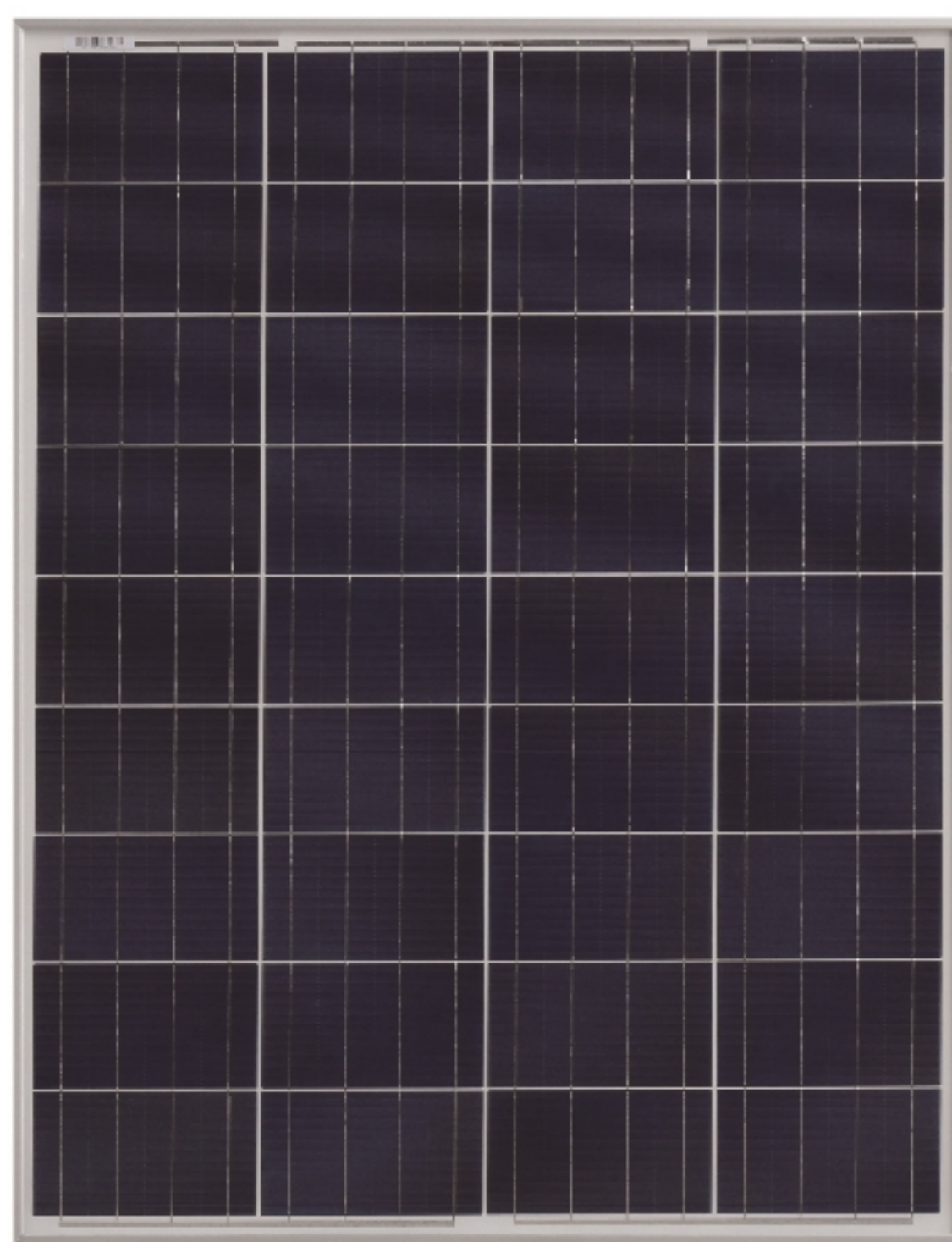
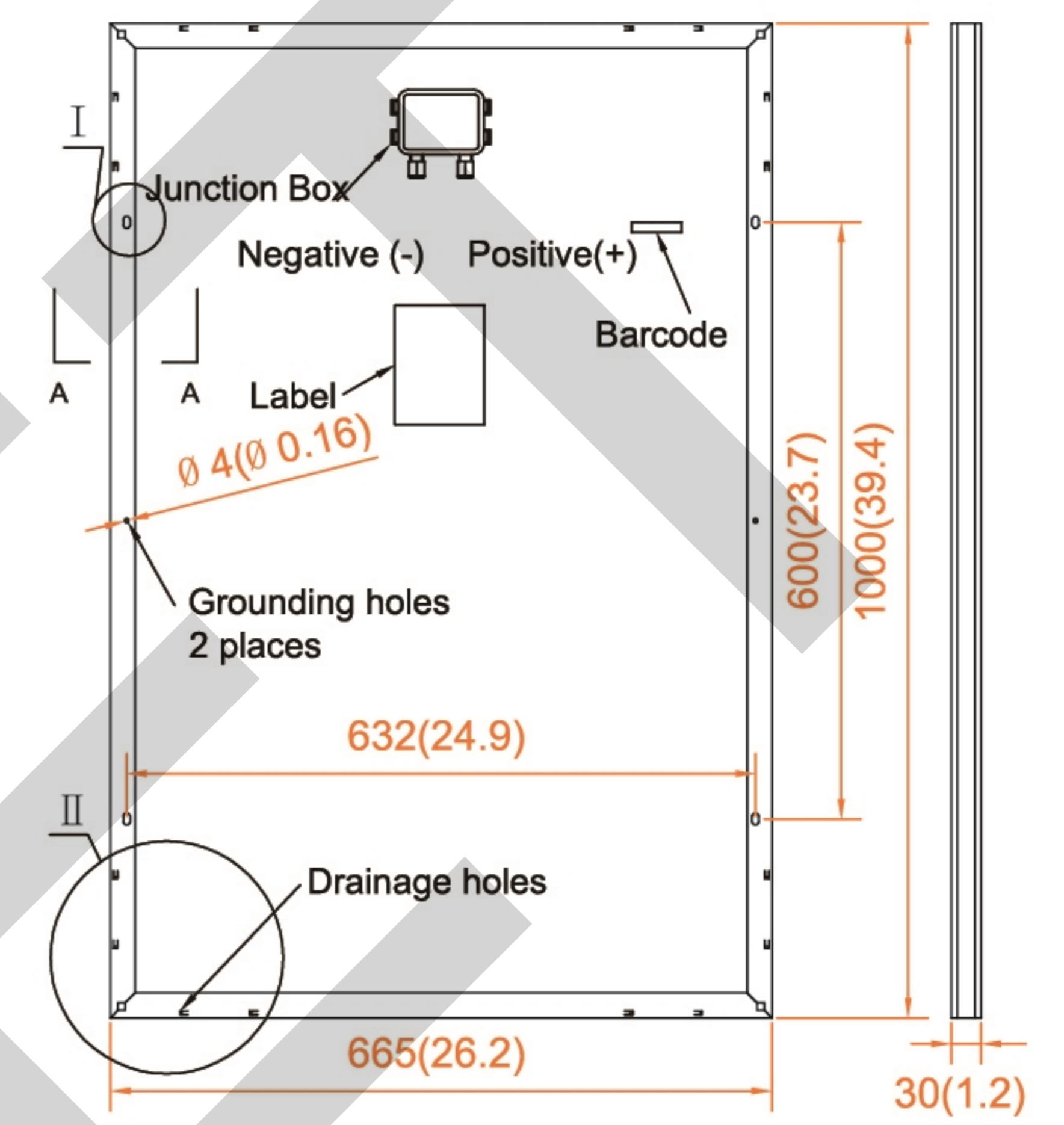

80W-90W

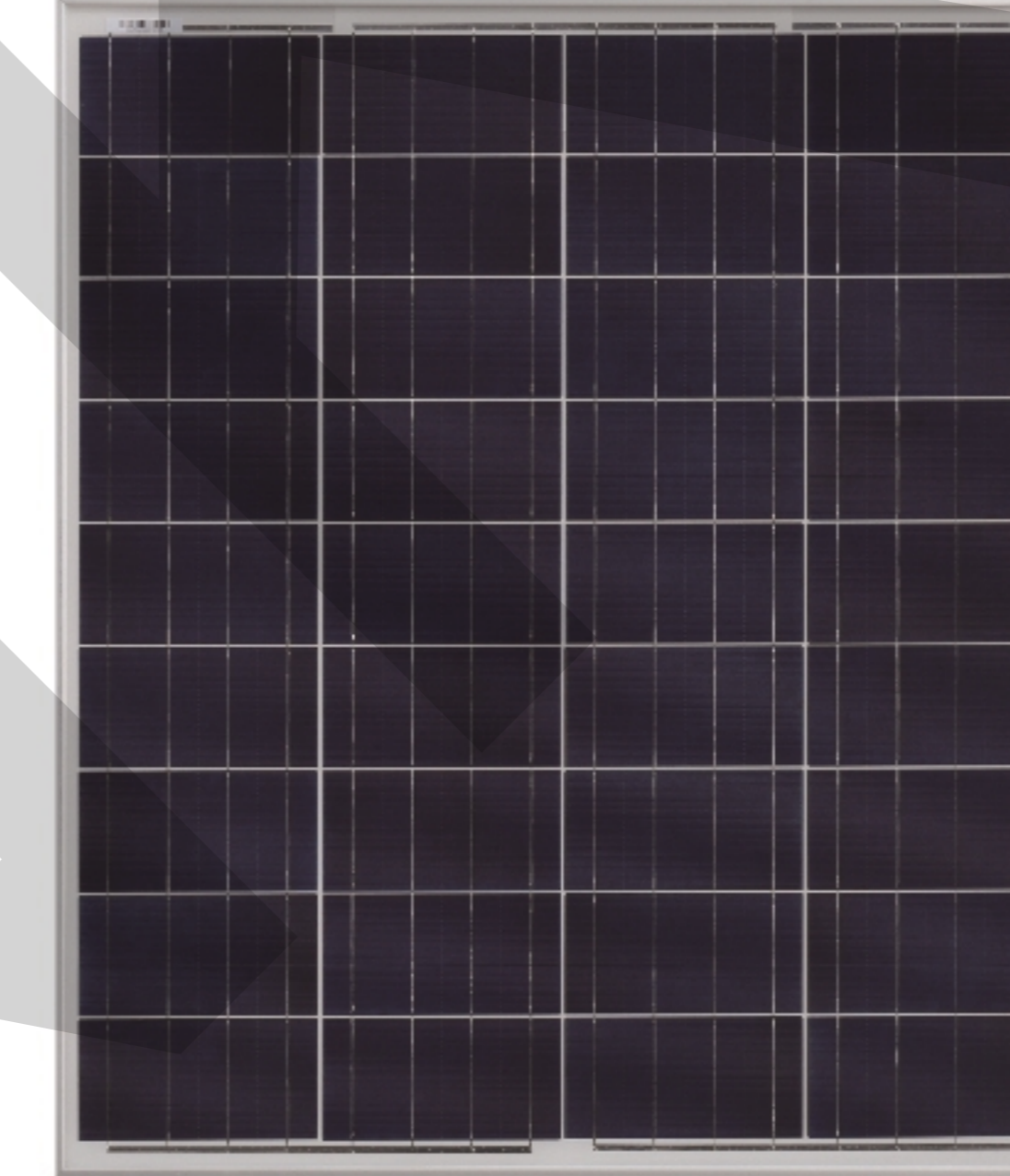
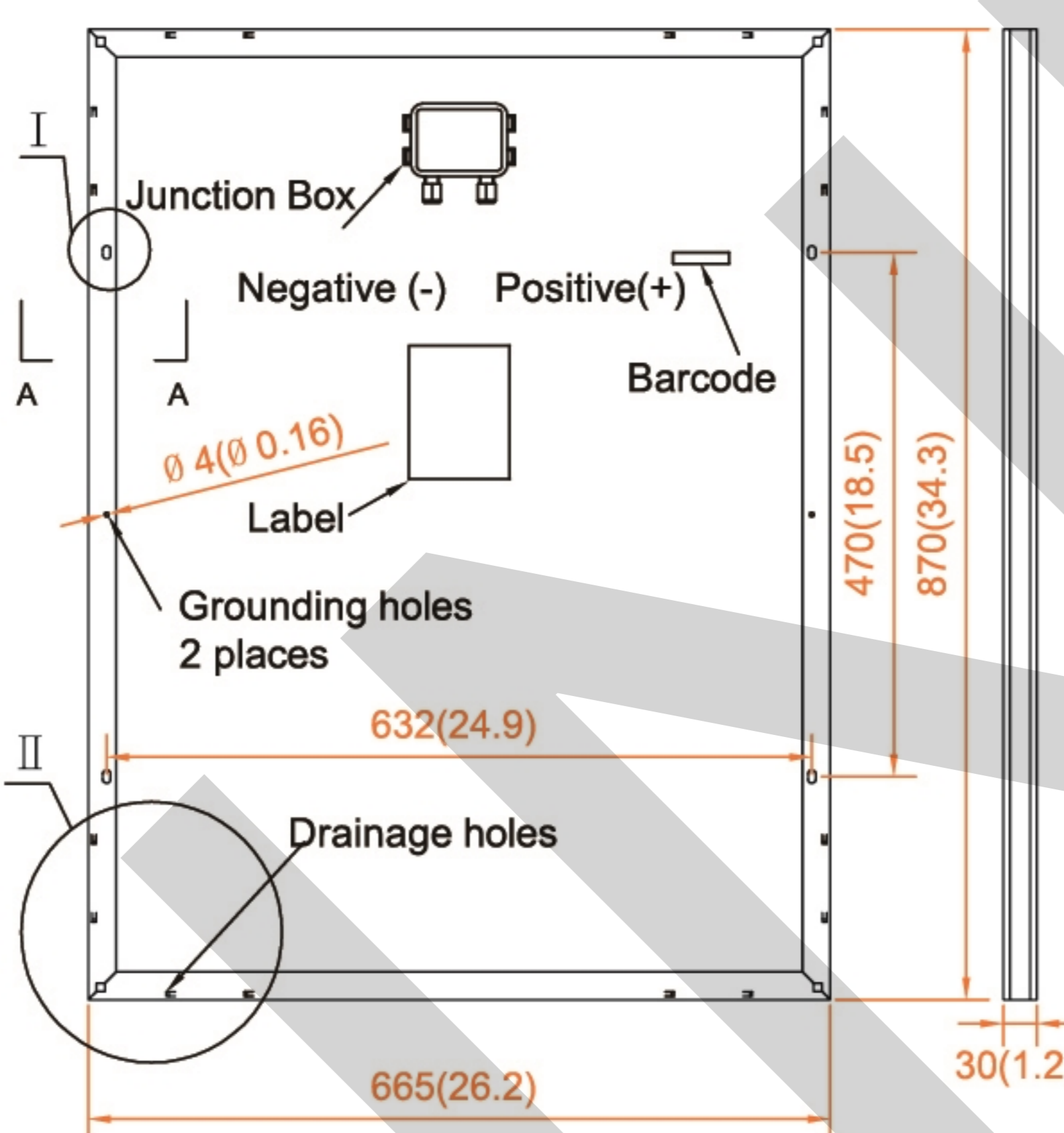

70W-75W

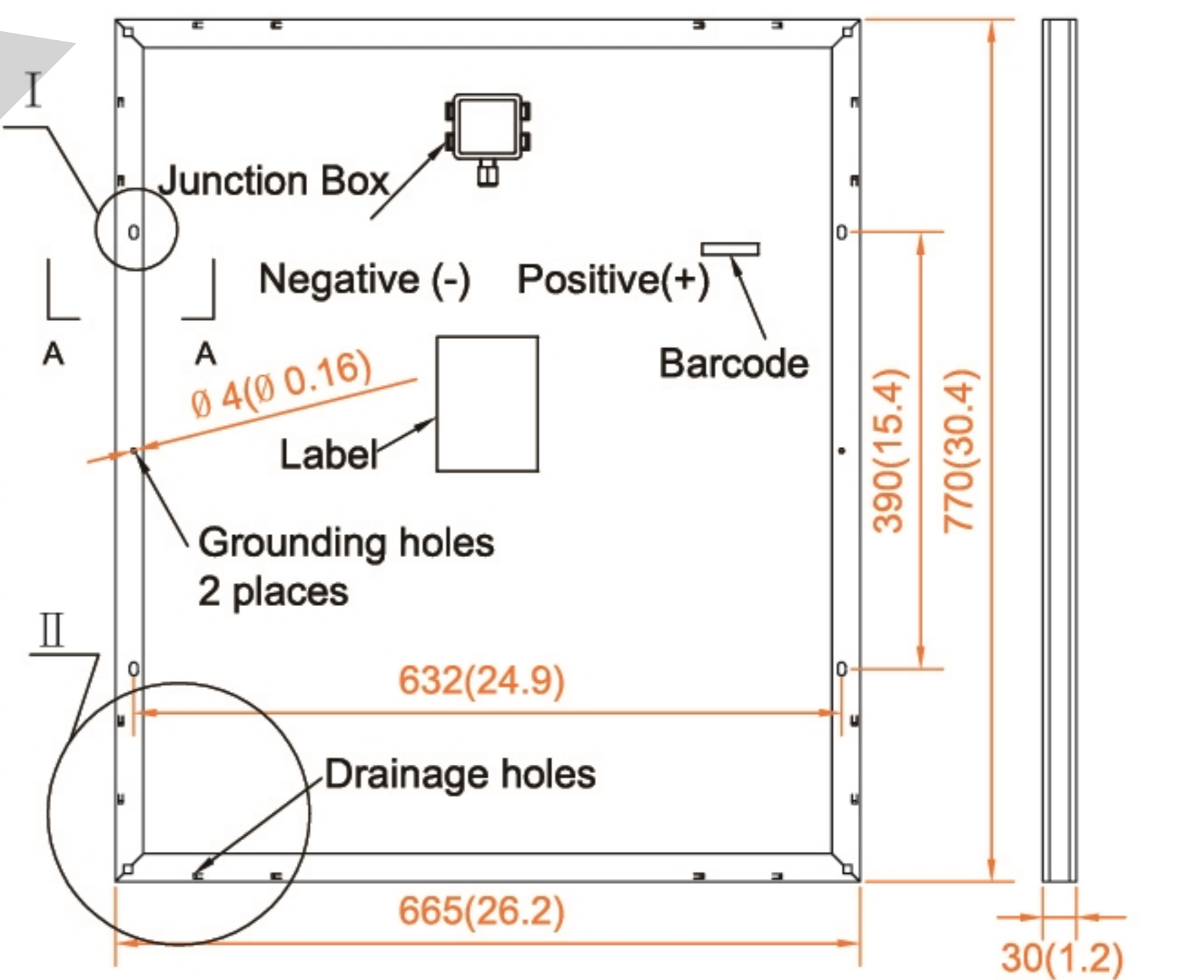

MANAGEMENT SYSTEM

- ISO 9001: Quality management system
- ISO 14001: Standard for environmental management system
- OHSAS 18001: International standard for occupational health and safety assessment system

PRODUCT CERTIFICATES

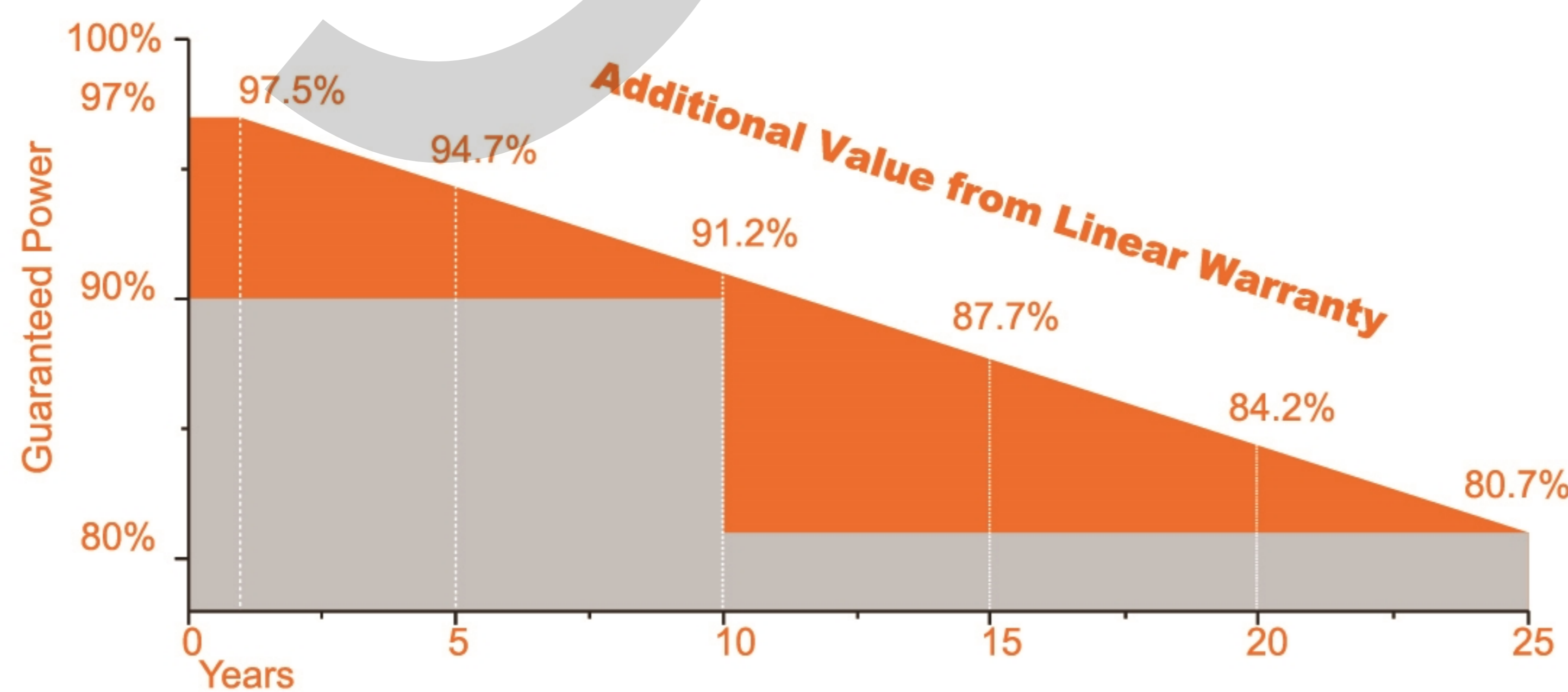
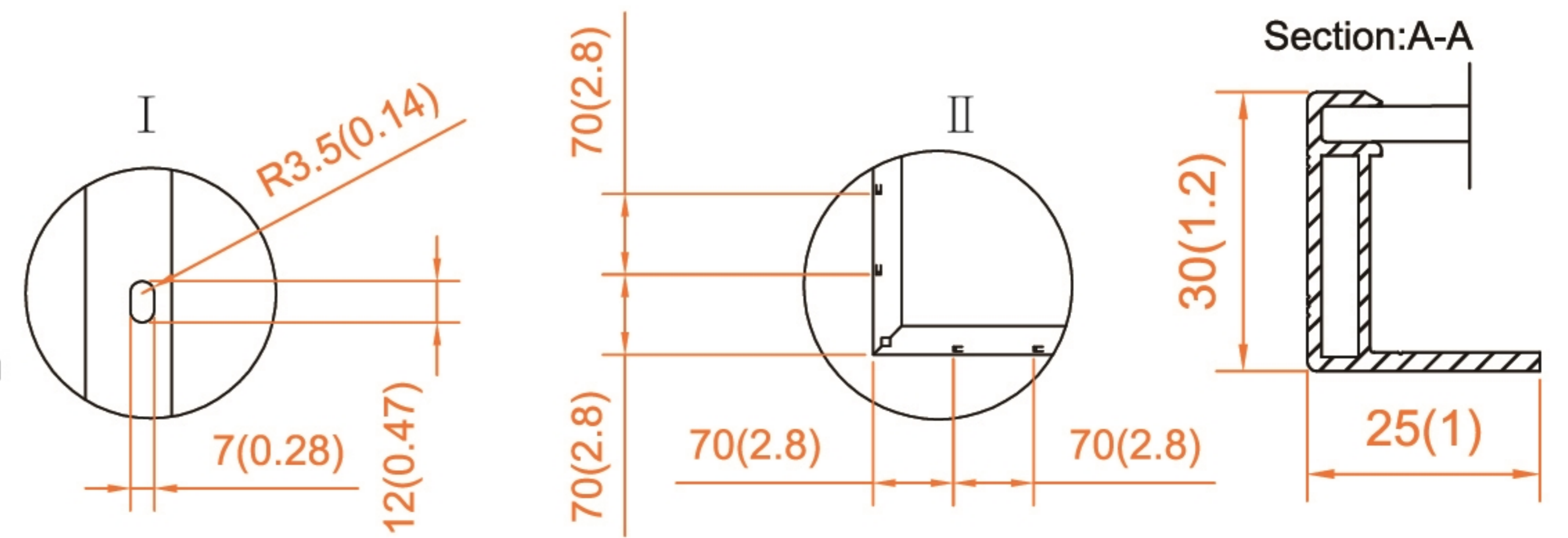

*All Dimensions in mm(inch)
 *The above drawing is a graphical representation of the product.
 For engineering quality drawings please contact SUNKET.

WARRANTY

- 5** Years Material & Craft Quality assurance
- 10** Years 90% Output Power guarantee
- 25** Years 80% Output Power guarantee

Specifications are subject to change without further notification SKT-EN-2017V1.0 © Copyright 2017 Sunket

Electrical Characteristics (STC)

Module Type	SKT70P-12	SKT75P-12	SKT80P-12	SKT85P-12	SKT90P-12
Maximum Power- Pmax(W)	70	75	80	85	90
Open Circuit Voltage - Voc(V)	22.2	22.4	22.2	22.4	22.6
Short- Circuit Current - Isc(A)	4.15	4.40	4.75	4.99	5.23
Voltage at Pmax -Vmp(V)	18.2	18.4	18.2	18.4	18.6
Current at Pmax - Imp(A)	3.85	4.08	4.40	4.62	4.84
Module Efficiency - η_m (%)	13.67	14.65	13.83	14.69	15.56

Module Type	SKT95P-12	SKT100P-12	SKT105P-12	SKT110P-12	SKT115P-12
Maximum Power- Pmax(W)	95	100	105	110	115
Open Circuit Voltage - Voc(V)	22.2	22.4	22.6	22.2	22.4
Short- Circuit Current - Isc(A)	5.64	5.87	6.10	6.53	6.75
Voltage at Pmax -Vmp(V)	18.2	18.4	18.6	18.2	18.4
Current at Pmax - Imp(A)	5.22	5.43	5.65	6.04	6.25
Module Efficiency - η_m (%)	14.29	15.04	15.79	14.77	15.44

STC: Irradiance 1000W/m², Cell Temperature 25°C, Air Mass 1.5
Power measurement tolerance:0~+3%

Mechanical Specifications

Module Type	SKT110P/115P-12	SKT95P~105P-12	SKT80P~90P-12	SKT70P/75P-12
External Dimensions	1120×665×30mm	1000×665×30 mm	870×665×30mm	770×665×30 mm
Weight	8.4kg	7.5 kg	6.5kg	5.7 kg
Poly Solar Cells	117×156mm (36pcs)	104×156mm (36pcs)	90×156mm (36pcs)	78×156mm (36pcs)
Front Glass	3.2 mm tempered, low iron	3.2 mm tempered, low iron	3.2 mm tempered, low iron	3.2 mm tempered, low iron
Frame	Anodized aluminum alloy	Anodized aluminum alloy	Anodized aluminum alloy	Anodized aluminum alloy
Junction Box	IP67	IP67	IP67	IP67
Mechanical Load	5400 Pa	5400 Pa	5400 Pa	5400 Pa

Packing Configuration

Module Type	SKT110P/115P-12	SKT95P~105P-12	SKT80P~90P-12	SKT70P/75P-12
Carton Dimensions	1135×680×175mm	1015×680×175mm	885×680×175 mm	785×680×175 mm
Pallet Dimensions	1400×1150×2170mm	1400×1100×2160mm	1800×1100×2170mm	1600×1100×2170mm
Pallet Weight	1074kg	966kg	1264kg	1115kg
Pieces/Pallet	120(5pcs/carton)	120(5pcs/carton)	180(5pcs/carton)	180(5pcs/carton)

I-V Curve (SKT100P-12)

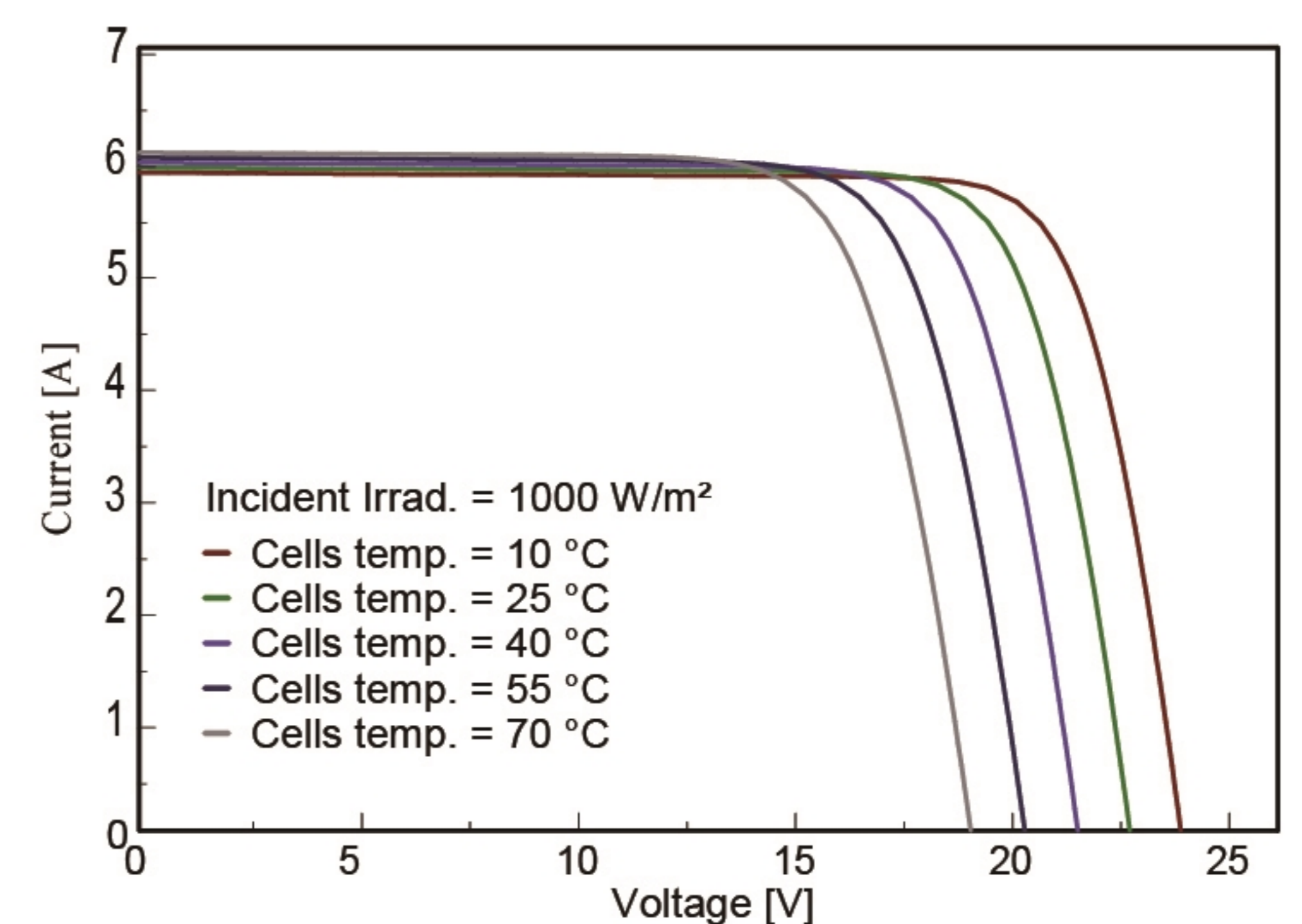
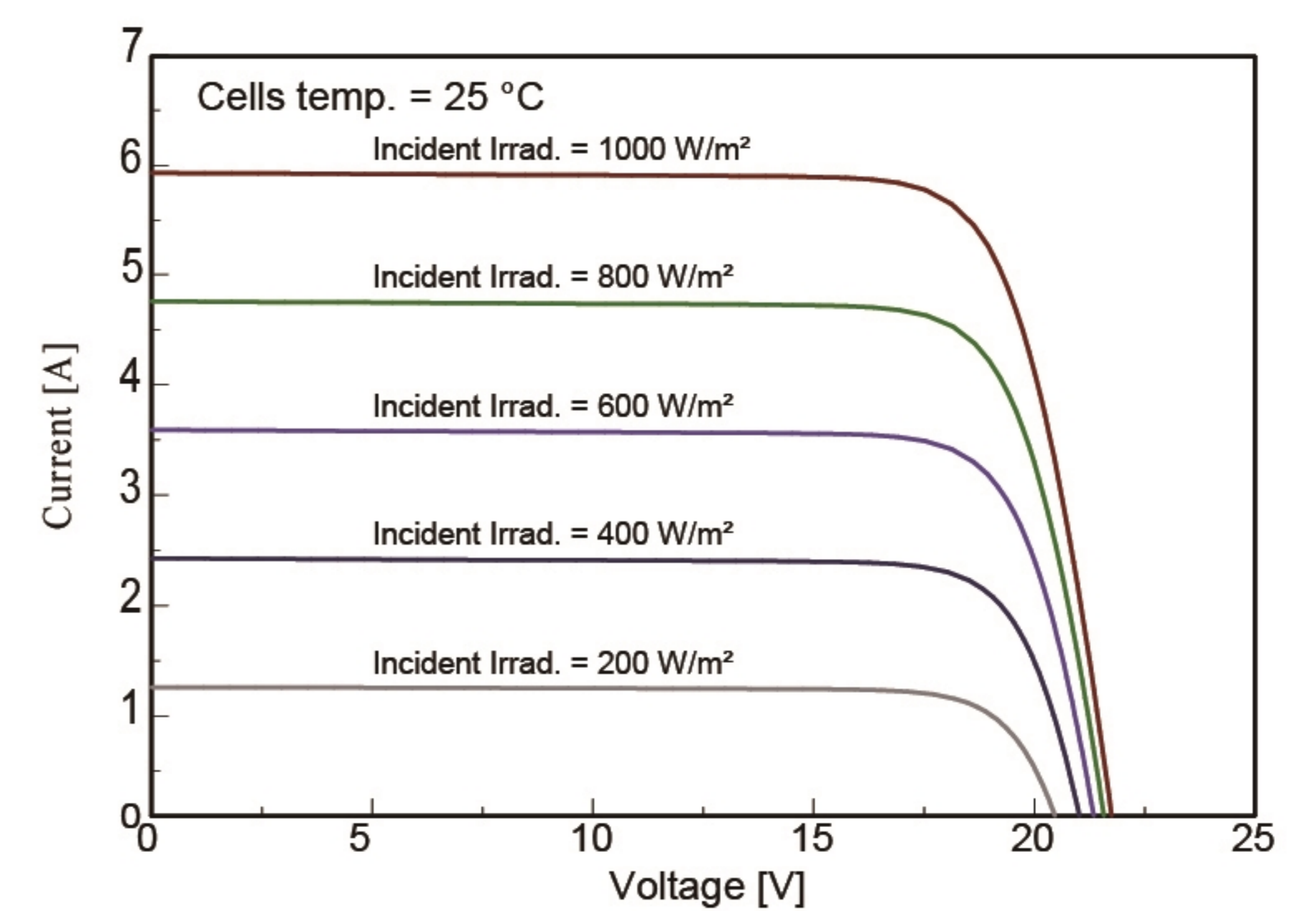

Specifications are subject to change without further notification SKT-EN-2017V1.0 © Copyright 2017 Sunket