

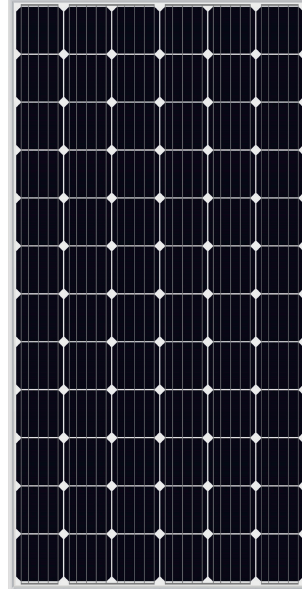

BQ-6MA (-HV) 365-380_W



KEY FEATURES



Tested and certified according to newest IEC standard
IEC61730-1:2016 IEC61215-1:2016
IEC61730-2:2016 IEC61215-2:2016



Safety for salt mist corrosion
Safety for ammonia corrosion



Bankable products



Outstanding power output capability at low irradiance



Triple 100% Electroluminescence (EL) tests minimize breakage rate



Top rank in Photon yield measurement



Safety for fire risk
(Class C tested in TÜV SÜD and Rheinland)



Anti-PID products, passing TÜV SÜD system voltage durability test



World 1st company to pass "Thresher Test" and "On-site Power Measurement Validation" certificate

Warranty

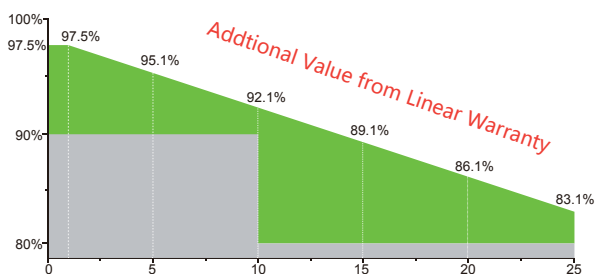

10 Years

Guarantee on product material and workmanship

25 Years

linear power output warranty

Product Certificates



BQ SOLARTECH CO., LTD

+86 13758135482 sales@bqsolartech.com

www.bqsolartech.com

Electrical Characteristics

Module Type	BQ-365-6MA-HV		BQ-370-6MA-HV		BQ-375-6MA-HV		BQ-380-6MA-HV	
	STC	NOCT	STC	NOCT	STC	NOCT	STC	NOCT
Maximum Power - P_{mp} (W)	365	271	370	274	375	278	380	282
Open Circuit Voltage - V_{oc} (V)	47.6	44.0	47.8	44.1	48.0	44.3	48.3	44.6
Short Circuit Current - I_{sc} (A)	9.78	7.90	9.88	7.97	9.96	8.05	10.02	8.11
Maximum Power Voltage - V_{mp} (V)	38.7	36.3	38.9	36.4	39.1	36.6	39.4	36.9
Maximum Power Current - I_{mp} (A)	9.44	7.47	9.52	7.53	9.60	7.60	9.65	7.65
Module Efficiency STC- η_m (%)	18.81/18.68		19.07/18.93		19.33/19.19		19.58/19.44	
Power Tolerance (W)	(0,+4.99)							
Maximum System Voltage (V)	1500 VDC							
Maximum Series Fuse Rating (A)	20A							
Pmax Temperature Coefficient	-0.36 %/°C							
Voc Temperature Coefficient	-0.28 %/°C							
Isc Temperature Coefficient	+0.05 %/°C							
Operating Temperature	-40~+85 °C							
Nominal Operating Cell Temperature	45±2 °C							

STC: Irradiance 1000 W/m² module temperature 25°C AM=1.5

NOCT: Irradiance 800 W/m² ambient temperature 20° C wind speed :1m/s Power measurement tolerance: +/-3%

I-V Curve

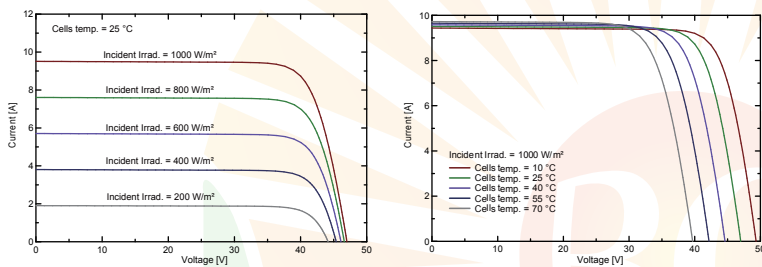

Technical drawing(BQ-XXX-6MA)

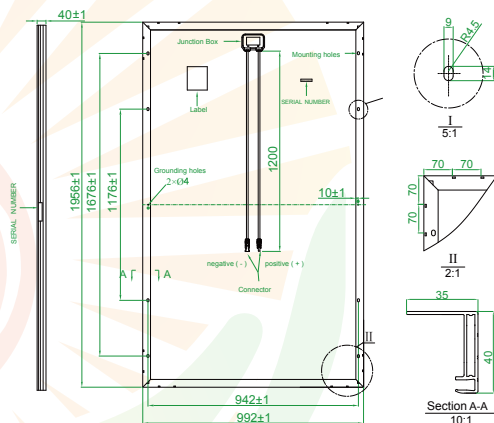

Mechanical Specifications

External Dimension	1956 x 992 x 40mm/1970 x 992 x 40mm
Weight	21.5kg/22.0kg
Solar Cells	PERC Mono crystalline 156.75 x 156.75 mm (72pcs)
Front Glass	3.2 mm AR coating tempered glass, low iron
Frame	Anodized aluminium alloy
Junction Box	IP68, 3 diodes
Output Cables	4.0 mm ² , cable length:1200 mm
Connector	MC4 Compatible
Mechanical Load	5400 Pa

Technical drawing(BQ-XXX-6MA-HV)

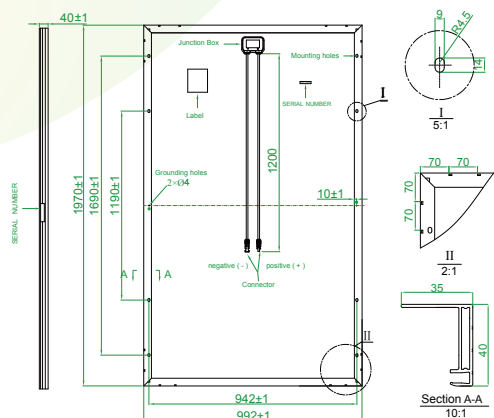

Packing Configuration

External Dimension	1956 x 992 x 40mm/1970 x 992 x 40mm		
Container	20' GP	40' GP	40' HQ
Pieces per Pallet	27	27	27+2*
Pallets per Container	10	22	22
Pieces per Container	270	594	638

* 27+2 pieces per pallet is the special package which only suits for container transport. For details, please consult SERAPHIM.

* All Dimensions in mm.
* The above drawing is a graphical representation of the product.

BQ SOLARTECH CO., LTD

+86 13758135482 sales@bqsolartech.com

www.bqsolartech.com