



YS 270-280 SM / Monocrystalline Single Glass 54 Series

270W/275W/280W

10
Years
Product warranty

25
Years
Linear power
output
Warranty



High output efficiency

PID Free ensuring high efficiency output of the system.



Superior weak light effect

Excellent module efficiency in the weak light conditions.



Excellent loading capacity

Passed mechanical load testing 5400Pa



Strong adaptability

Passed TUV salt mist and ammonia resistance testing.



Easy Installation

Suitable for a variety of applications



Durability

High quality raw materials and fine workmanship

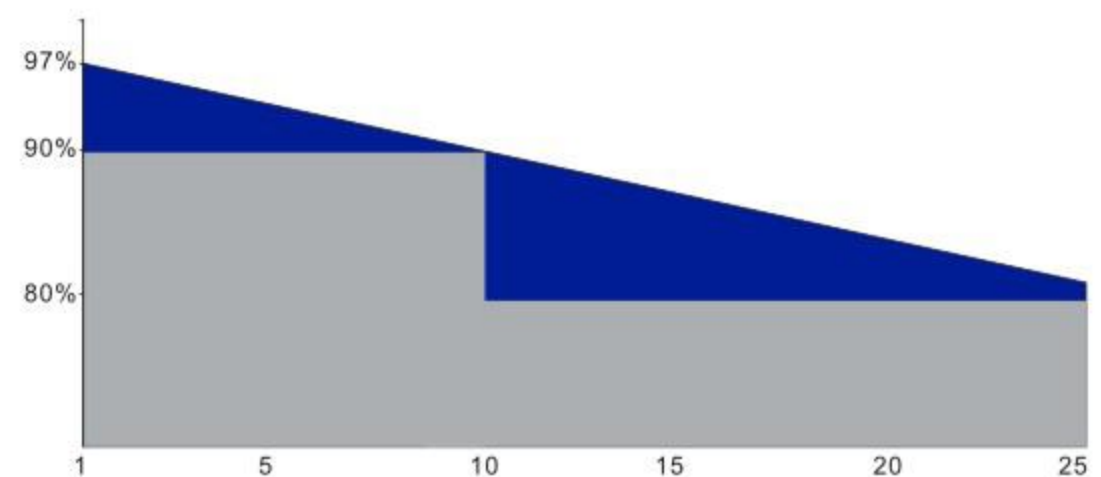

GREEN ENERGY PRODUCTS



Tel: +86 753 2880123

Email: info@gdyssolar.com

Web: www.gdyssolar.com

Guangdong Yaosheng Solar Technology Co., Ltd.

SPECIFICATION

Module	YS270SM-54	YS275SM-54	YS280SM-54
Maximum Power (Pmax W)	270	275	280
Open-circuit Voltage (Voc V)	36.23	36.44	36.77
Maximum Power Voltage (Vmp V)	29.38	29.57	29.88
Short-circuit Current (ISC A)	9.64	9.75	9.85
Maximum Power Current (Imp A)	9.19	9.30	9.37
Module Efficiency STC (%)	18.39	18.74	19.07
Power Tolerance	0~+5W		
Temperature coefficients of Isc(A-Isc)	+0.037%/°C		
Temperature coefficients of Voc(B-Voc)	-0.34%/°C		
Temperature coefficients of Pmax(C-Pmp)	-0.48%/°C		
Standard Testing Condition(STC)	Irradiance 1000W/ m ² , Cell Temperature 25°C ± 2 , AM1.5G		

Remark: The technical specification belongs to monocrystalline 54-cell module only.

SPECIFICATION

Module Type	Monocrystalline
Dimension	1480*992*30 (mm)
Weight	16.2 (kg)
No. of Cells	54 (pcs)
Packing	30 sets/ctn

APPLICATION

Maximum System Voltage	1000V/1500V DC(IEC)
Operating Temperature	-40°C~+85°C
Maximum Series Fuse Rating	20A
Nominal Operating Cell Temperature (NOCT)	45 ± 2°C
Application Class	Class A

Engineering Drawing

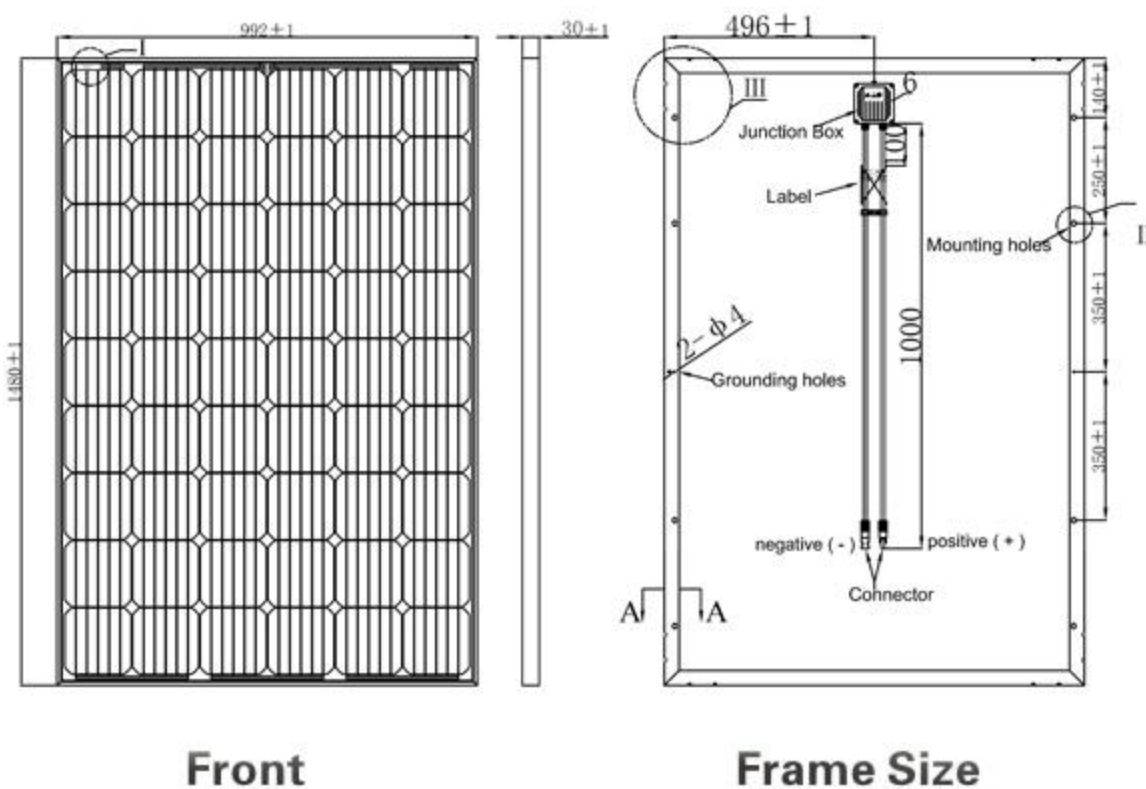

Linear Characteristic

Current-Voltage Curve

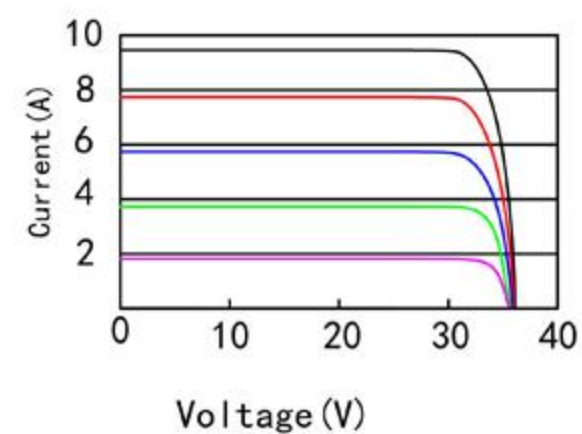

power-Voltage Curve

