

Solar inverters

ABB string inverters
UNO-7.6/8.6-TL-OUTD
7.6kW to 8.6kW



UNO 7.6 and 8.6 is a feature-rich transformerless inverter that is powerful and flexible enough to operate like two inverters. This means fewer inverters are needed to accommodate residential installations.

Reducing cost of installation.

Available in 7.6kW or 8.6kW, the ABB UNO 7.6 and 8.6 inverters are well suited for North American residential rooftop installations and provide the system flexibility, levels of performance and reliability that designers need. The wide input-voltage range makes the inverter suitable for installations utilizing a reduced string size.

ABB is the only manufacturer who can offer a fully-loaded, large residential system using one inverter.

ABB's high-speed and precise Multiple Power Point Tracker (MPPT) algorithm enables real-time power tracking and improved energy harvesting. The dual MPPT input enables more orientations of PV strings to be connected at the same time, and unbalanced strings on each MPPT channel; thereby, maximizing the energy harvesting and flexibility. These inverters are extremely lightweight and simple to wall mount, while still featuring an integrated DC disconnect with combiner, lowering overall installation cost.

Highlights:

- Dual independent MPPT channel compatible with a 40A residential panel sized breaker
- Outdoor NEMA 4X rated enclosure for unrestricted use under any environmental conditions
- Wide input range for increased stringing flexibility
- Minimizes installation space with side-by-side installation
- 96.5 percent CEC efficiency

Additional highlights:

- Single-phase and split-phase output
- Offers an extra quiet, transformer-less inverter architecture
- Fully integrated DC disconnect and wiring box saves installation time and cost
- Flexible data monitoring options to view inverter performance where and how you need it
- Comes with a standard 10-year warranty, available extensions to 15 and 20 years
- Available with optional Wifi Logger Card for wireless monitoring



Technical data and types

Type code	UNO-7.6-TL-OUTD-S-US-A			UNO-8.6-TL-OUTD-S-US-A	
Nominal output power	7600W			8600W	
Maximum output power	8300W			9400W	
Rated grid AC voltage	208V	240V	277V	240V	277V
Input side					
Number of independent MPPT channels	2				
Maximum usable power for each channel	5400W				
Absolute maximum voltage (Vmax)	600V				
Start-up voltage (Vstart)	200V (adj. 120-350V)				
Full power MPPT voltage range	165-480V			185-480V	
Operating MPPT voltage range	0.7xVstart-580 (≥ 90V)				
Maximum current (I _{dcmax}) for both MPPT in parallel	48A				
Maximum usable current per channel	24A				
Maximum short circuit current limit per channel	30A				
Number of wire landing terminals per channel	2 pairs				
Array wiring termination	Terminal block, pressure clamp, AWG12-AWG4				
Output side					
Grid connection type	1Ø/2W	Split-Ø/3W	1Ø/2W	Split-Ø/3W	1Ø/2W
Grid voltage range (V _{min} -V _{max})	183-228V	211-264V	244-304V	211-264V	244-304V
Nominal grid frequency	60Hz				
Adjustable grid frequency range	57-63Hz				
Maximum current (I _{acmax})	36.5A _{RMS}	32A _{RMS}	27.5A _{RMS}	36A _{RMS}	31A _{RMS}
Power factor	>0.995(adj. ±0.9, or fixed to ± 0.8 with max 7.6kVA / 8.6kVA)				
Total harmonic distortion (@ rated output power)	<2%				
Grid wiring termination type	Terminal block, pressure clamp AWG10-AWG4				
Input protection devices					
Reverse polarity protection	Yes				
Over-voltage protection type	Varistor, 2 for each channel				
PV array ground fault detection	Pre start-up R _{iso} and dynamic GFDI (requires floating arrays)				
Output protection devices					
Anti-islanding protection	Meets UL1741 / IEEE1547 requirements				
External AC OCPD rating	50A _{RMS}	40A _{RMS}	40A _{RMS}	50A _{RMS}	40A _{RMS}
Over-voltage protection type	Varistor, 2 (L ₁ - L ₂ / L ₁ - G)				
Efficiency					
Maximum efficiency	97.5%				
CEC efficiency	96.5%				
Operating performance					
Nighttime consumption	<0.6 W _{RMS}				
Stand-by consumption	< 8 W _{RMS}				
Communication					
User-interface	5.5" x 1.25" graphic display				
Remote monitoring (1xRS485 included)	VSN700 Data Logger (opt.), VSN300 Wifi Logger Card (opt.)				
Environmental					
Ambient air operating temperature range	-13°F to 140°F (-25°C to +60°C) with derating above 122°F (50°C)				
Ambient air storage temperature range	-40°F to 176°F (-40°C to +80°C)				
Relative humidity	0-100% condensing				
Acoustic noise emission level	<50 db (A) @ 1m				
Maximum operating altitude without derating	6560ft (2000m)				

Block diagram of UNO-7.6/8.6-TL-OUTD

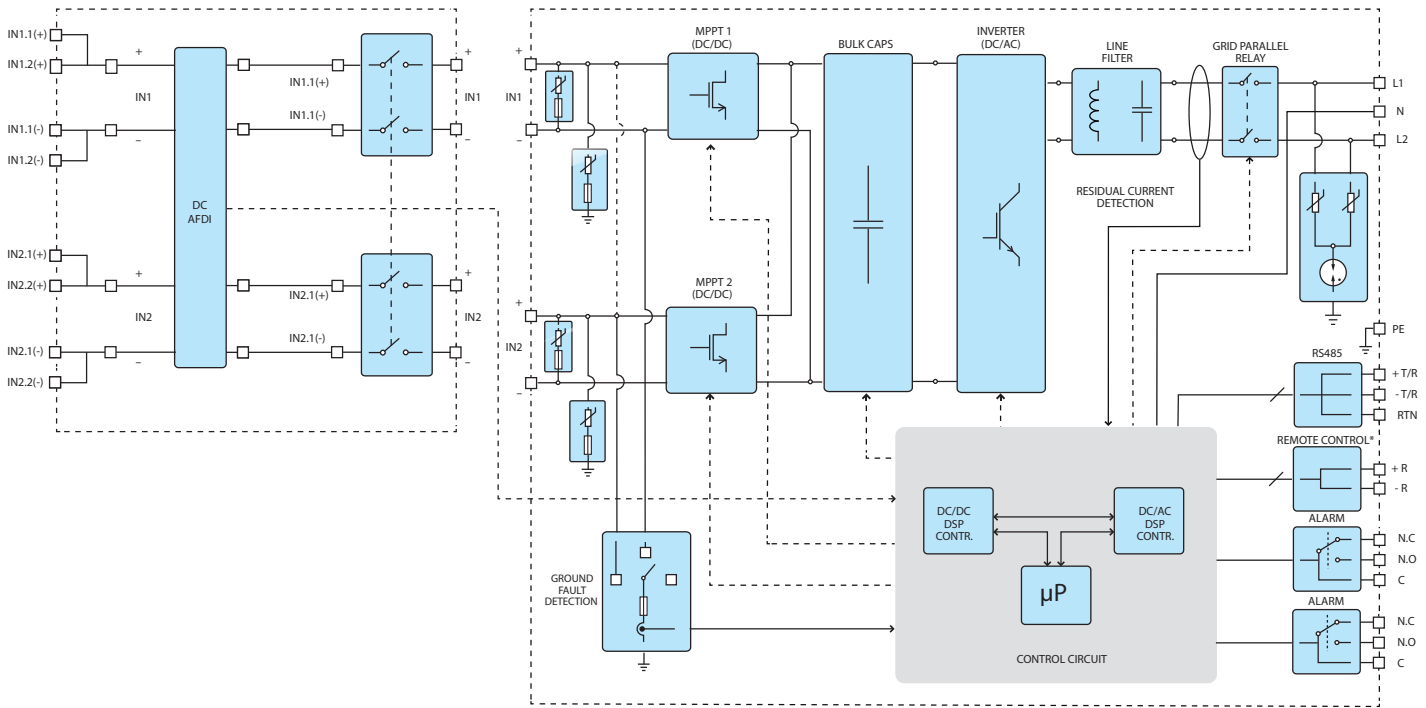

UNO-7.6-TL-OUTD-S-US

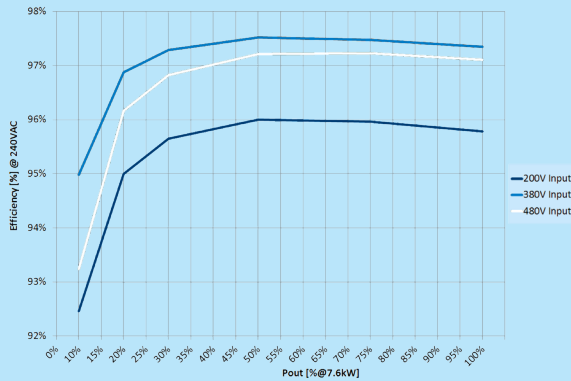

UNO-8.6-TL-OUTD-S-US

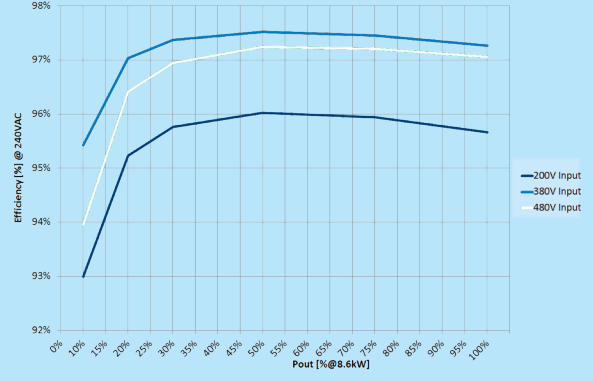

Technical data and types

Type code	UNO-7.6-TL-OUTD-S-US-A	UNO-8.6-TL-OUTD-S-US-A
Mechanical specifications		
Enclosure rating		NEMA 4X
Cooling		Natural convection
Dimensions H x W x D		18.9 x 22.8 x 8.8 in (480 x 583 x 223mm) Inverter only 29.3 x 22.9 x 8.8 in (745 x 583 x 223mm) Including wiring box
Weight		81.5lb (37kg)
Shipping weight		103.5lb (47kg)
Mounting system		Wall bracket
Conduit connections	Bottom: (2) plugged 1/2" openings, (2) plugged 1" openings, (2) Concentric KOs 3/4", 1" Sides: (2) Concentric KOs 3/4", 1"	
DC switch rating (per contact) (A/V)	25A / 600Vdc	
Safety		
Isolation level	Transformerless - floating array	
Safety and EMC standard	UL 1741, IEE 1547, IEE1547.1, CSA-C22.2N. 107.1-01, UL1998 UL1699B, FCC Part 15 Class B	
Safety approval	cCSA _{us}	
Warranty		
Standard warranty	10 years	
Extended warranty	15 & 20 years	
Available models		
With DC switch and wiring box, arc fault detector and interruptor	UNO-7.6-TL-OUTD-S-US-A	UNO-8.6-TL-OUTD-S-US-A

All data is subject to change without notice

Support and service

ABB supports its customers with a dedicated, global service organization in more than 60 countries, with strong regional and national technical partner networks providing a complete range of life cycle services.

For more information please contact your local ABB representative or visit:

www.abb.com/solarinverters

www.abb.com

© Copyright 2015 ABB. All rights reserved. Specifications subject to change without notice.

