

# ABB central inverters

PVS800

100 to 1000 kW



**ABB central inverters raise reliability, efficiency and ease of installation to new levels. The inverters are aimed at system integrators and end users who require high performance solar inverters for large photovoltaic (PV) power plants. The inverters are available from 100 up to 1000 kW, and are optimized for cost-efficient multi-megawatt power plants.**

## **World's leading inverter platform**

The ABB central inverters have been developed on the basis of decades of experience in the industry and proven technology platform. Unrivalled expertise from the world's market and technology leader in frequency converters is the hallmark of this solar inverter series.

Based on ABB's highly successful platform and the most widely used frequency converters on the market – the inverters are the most efficient and cost-effective way to convert the direct current (DC) generated by solar modules into high-quality and CO<sub>2</sub>-free alternating current (AC) that can be fed into the power distribution network.

## **Solar inverters from ABB**

ABB central inverters are ideal for large PV power plants but are also suitable for large-sized power plants installed in commercial or industrial buildings. High efficiency, proven components, compact and modular design and a host of life cycle services ensures ABB central inverters provide a rapid return on investment.

## **Highlights**

- High total performance
- Modular and compact product design
- Extensive DC and AC side protection
- Full grid support functionality
- Fast and easy installation
- Complete range of industrial-type data communication options, including remote monitoring
- Life cycle service and support through ABB's extensive global service network

String inverters

PV + Storage

Central inverters

Turnkey stations

Monitoring and communications



### Maximum energy and feed-in revenues

ABB central inverters have a high total efficiency level. Optimized and accurate system control and a maximum power point tracking (MPPT) algorithm together with high efficiency power converter design ensure that maximum energy is delivered to the power distribution network from the PV modules. For end users this generates the highest possible revenues from the feed-in tariffs.

### Proven ABB components

The inverters comprise proven ABB components with a long track record of performance excellence in demanding applications and harsh environments. Equipped with extensive electrical and mechanical protection, the inverters are engineered to provide a long and reliable service life of at least 20 years.

### Compact and modular design

The inverters are designed for fast and easy installation. The industrial design and modular platform provides a wide range of options like remote monitoring, fieldbus connection and modular and flexible DC input cabinet. The integrated DC cabinet saves space and costs as the solar array junction boxes can be connected directly to the inverter DC cabinet

fused busbars. The inverters are customized to meet end user needs and are available with short delivery times.

### Effective connectivity to power distribution network

ABB's transformerless central inverter series enables system integrators to design the PV power plant using optimum combination of different power rating inverters. Inverters are connected to the medium voltage (MV) power distribution network either centrally or in a distributed manner depending on the plant size and shape and network connection position.

### Advanced grid support features

ABB central inverter software includes all the latest grid support and monitoring features including active power limitation, low voltage ride through (LVRT) with current feed-in and reactive power control. Active and reactive power output can be limited by using an external source. Active power can also be limited automatically as a function of grid frequency.

All grid support functions are parameterized allowing easy adjusting for local utility requirements. ABB central inverters are also able to support grid stability even at night by providing reactive power with the DC input disconnected.

# ABB central inverters

## PVS800

100 to 1000 kW



### Technical data and types

Type designation	-0100kW-A	-0250kW-A	-0315kW-B	-0500kW-A	-0630kW-B	-0875kW-B	-1000kW-C
PVS800-57	100 kW	250 kW	315 kW	500 kW	630 kW	875 kW	1000 kW
<b>Input (DC)</b>							
Maximum input power ( $P_{PV, max}$ ) <sup>1)</sup>	120 kWp	300 kWp	378 kWp	600 kWp	756 kWp	1050 kWp	1200 kWp
DC voltage range, mpp ( $U_{DC, mpp}$ )	450 to 825 V	450 to 825 V	525 to 825 V	450 to 825 V	525 to 825 V	525 to 825 V	600 to 850 V
Maximum DC voltage ( $U_{max(DC)}$ )	1000 V	1000 V	1000 V	1100 V	1100 V	1100 V	1100 V
Maximum DC current ( $I_{max(DC)}$ )	245 A	600 A	615 A	1145 A	1230 A	1710 A	1710 A
Number of protected DC inputs	1 (+/-) / 4 <sup>2)</sup>	2, 4, 8 (+/-)	2, 4, 8 (+/-)	4 to 15 (+/-)	4 to 15 (+/-)	8 to 20 (+/-)	8 to 20 (+/-)
<b>Output (AC)</b>							
Nominal power ( $P_{N(AC)}$ ) <sup>3)</sup>	100 kW	250 kW	315 kW	500 kW	630 kW	875 kW	1000 kW
Maximum output power <sup>4)</sup>	100 kW	250 kW	345 kW	600 kW	700 kW	1050 kW	1200 kW
Power at $\cos\phi = 0.95$ <sup>3)</sup>	96 kW	240 kW	300 kW	475 kW	600 kW	830 kW	950 kW
Nominal AC current ( $I_{N(AC)}$ )	195 A	485 A	520 A	965 A	1040 A	1445 A	1445 A
Nominal output voltage ( $U_{N(AC)}$ ) <sup>5)</sup>	300 V	300 V	350 V	300 V	350 V	350 V	400 V
Output frequency	50/60 Hz	50/60 Hz	50/60 Hz	50/60 Hz	50/60 Hz	50/60 Hz	50/60 Hz
Harmonic distortion, current <sup>6)</sup>	< 3%	< 3%	< 3%	< 3%	< 3%	< 3%	< 3%
Distribution network type <sup>7)</sup>	TN and IT	TN and IT	TN and IT	TN and IT	TN and IT	TN and IT	TN and IT
<b>Efficiency</b>							
Maximum <sup>8)</sup>	98.0%	98.0%	98.6%	98.6%	98.6%	98.7%	98.8%
Euro-eta <sup>8)</sup>	97.5%	97.6%	98.3%	98.2%	98.4%	98.5%	98.6%
<b>Power consumption</b>							
Own consumption in operation	310 W	310 W	310 W	490 W	490 W	650 W	650 W
Standby operation consumption	60 W	60 W	60 W	65 W	65 W	65 W	65 W
External auxiliary voltage <sup>9)</sup>	230 V, 50 Hz	230 V, 50 Hz	230 V, 50 Hz	230 V, 50 Hz	230 V, 50 Hz	230 V, 50 Hz	230 V, 50 Hz
<b>Dimensions and weight</b>							
Width/Height/Depth, mm (W/H/D)	1030/2130/690	1830/2130/680	1830/2130/680	2630/2130/708	2630/2130/708	3630/2130/708	3630/2130/708
Weight appr. <sup>10)</sup>	550	1100	1100	1800	1800	2320	2320

<sup>1)</sup> Recommended maximum input power

<sup>2)</sup> Optional MCB inputs, 80 A inputs

<sup>3)</sup> 100 and 250 kW units at 40°C. 315 and 630 kW at 45°C. 500, 875 and 1000 kW at 50°C.

<sup>4)</sup> At 25°C. See the user manual for details.

<sup>5)</sup> +/- 10%

<sup>6)</sup> At nominal power

<sup>7)</sup> Inverter side must be IT type

<sup>8)</sup> Without auxiliary power consumption at min  $U_{DC}$

<sup>9)</sup> 115 V, 60 Hz optional

<sup>10)</sup> For the smallest number of protected inputs

See the user manual for details

## ABB central inverter design and power network connection

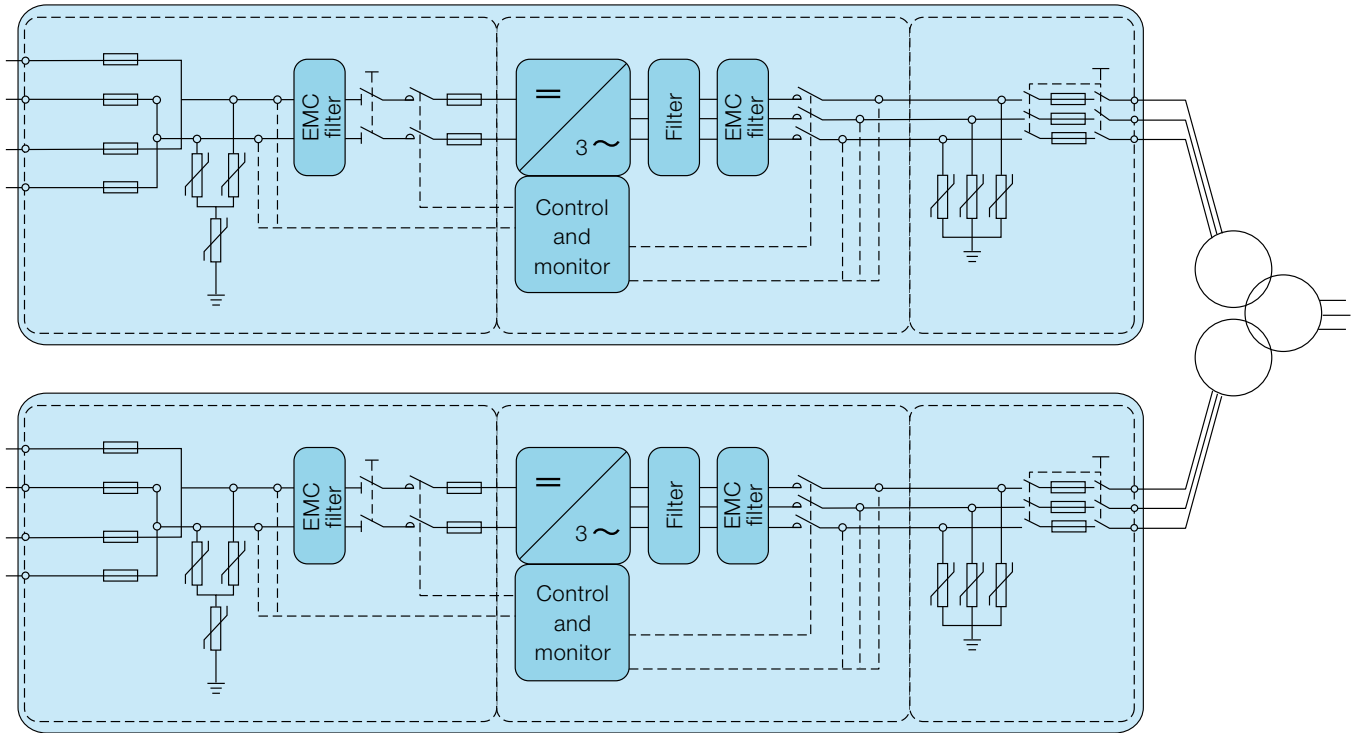

### Technical data and types

Type designation	-0100kW-A	-0250kW-A	-0315kW-B	-0500kW-A	-0630kW-B	-0875kW-B	-1000kW-C
<b>PVS800-57</b>	<b>100 kW</b>	<b>250 kW</b>	<b>315 kW</b>	<b>500 kW</b>	<b>630 kW</b>	<b>875 kW</b>	<b>1000 kW</b>
<b>Environmental limits</b>							
Degree of protection	IP42	IP42	IP42	IP42	IP42	IP42	IP42
Ambient temp. range (nom. ratings) <sup>11)</sup>	-15 to +40°C	-15 to +40°C	-15 to +45°C	-15 to +50°C	-15 to +45°C	-15 to +50°C	-15 to +50°C
Maximum ambient temperature <sup>12)</sup>	+50°C	+50°C	+55°C	+55°C	+55°C	+55°C	+55°C
Relative humidity, not condensing	15 to 95%	15 to 95%	15 to 95%	15 to 95%	15 to 95%	15 to 95%	15 to 95%
Maximum altitude (above sea level) <sup>13)</sup>	2000 m <sup>14)</sup>	2000 m <sup>14)</sup>	2000 m <sup>14)</sup>	4000 m	4000 m	4000 m	4000 m
Maximum noise level	75 dBA	75 dBA <sup>15)</sup>	75 dBA <sup>15)</sup>	75 dBA <sup>15)</sup>	75 dBA <sup>15)</sup>	75 dBA <sup>15)</sup>	75 dBA <sup>15)</sup>
Maximum air flow of the inverter section	1300 m <sup>3</sup> /h	2500 m <sup>3</sup> /h	2500 m <sup>3</sup> /h	5000 m <sup>3</sup> /h	5000 m <sup>3</sup> /h	7950 m <sup>3</sup> /h	7950 m <sup>3</sup> /h
<b>Protection</b>							
Ground fault monitoring <sup>16)</sup>	Yes	Yes	Yes	Yes	Yes	Yes	Yes
Grid monitoring	Yes	Yes	Yes	Yes	Yes	Yes	Yes
Anti-islanding	Yes	Yes	Yes	Yes	Yes	Yes	Yes
DC reverse polarity	Yes	Yes	Yes	Yes	Yes	Yes	Yes
AC and DC short circuit and over current	Yes	Yes	Yes	Yes	Yes	Yes	Yes
AC and DC over voltage and temperature	Yes	Yes	Yes	Yes	Yes	Yes	Yes
<b>User interface and communications</b>							
Local user interface	ABB local control panel						
Analog inputs/outputs	1/2	1/2	1/2	1/2	1/2	1/2	1/2
Digital inputs/relay outputs	3/1	3/1	3/1	3/1	3/1	3/1	3/1
Fieldbus connectivity	Modbus, PROFIBUS, EtherNet						
<b>Product compliance</b>							
Safety and EMC	CE conformity according to LV and EMC directives						
Certifications and approvals <sup>17)</sup>	VDE, CEI, UNE, RD, EDF, P.O. 12.3, BDEW, GOST, AS, ZA						
Grid support and grid functions	Reactive power compensation <sup>18)</sup> , power reduction, LVRT, HVRT, anti-islanding						

<sup>11)</sup> Frosting is not allowed. May need optional cabinet heating.

<sup>12)</sup> Power derating after 40°C/45°C/50°C

<sup>13)</sup> Power derating above 1000 m

<sup>14)</sup> With option 2000 to 4000 m

<sup>15)</sup> At partial power typically < 70 dBA

<sup>16)</sup> Optional

<sup>17)</sup> More detailed information, please contact ABB

<sup>18)</sup> Also during the night

# ABB central inverters

PVS800

100 to 1000 kW



---

## High total performance

- High efficiency
- Low auxiliary power consumption
- Efficient maximum power point tracking
- Long and reliable service life of at least 20 years

---

## Modular industrial design

- Compact and easy-to-maintain product design
- Fast and easy installation
- Integrated and flexible DC input cabinet

---

## Full grid support functionality

- Reactive power compensation also during the night time
- Active power limitation
- Low voltage ride through with current feed in

---

## Extensive protections

- DC and AC side protection with built-in fuses, surge protection and filters
- Increased reliability and safety with DC and AC side contactors
- Heavy-duty surge protection

---

## Grid code compatibility

- Wide country-specific grid code compliance
- Adjustability to various local utility requirements

---

## Proven technology

- Based on ABB's market-leading technology platform used in frequency converters

---

## Life cycle service and support

- ABB's extensive global service network
- Extended warranties
- Service contracts
- Technical support throughout the service life

---

## Wide communication options

- Complete range of industrial-type data communication options
- Ethernet/Internet protocol
- Remote monitoring

## Data communication principle for ABB central inverters

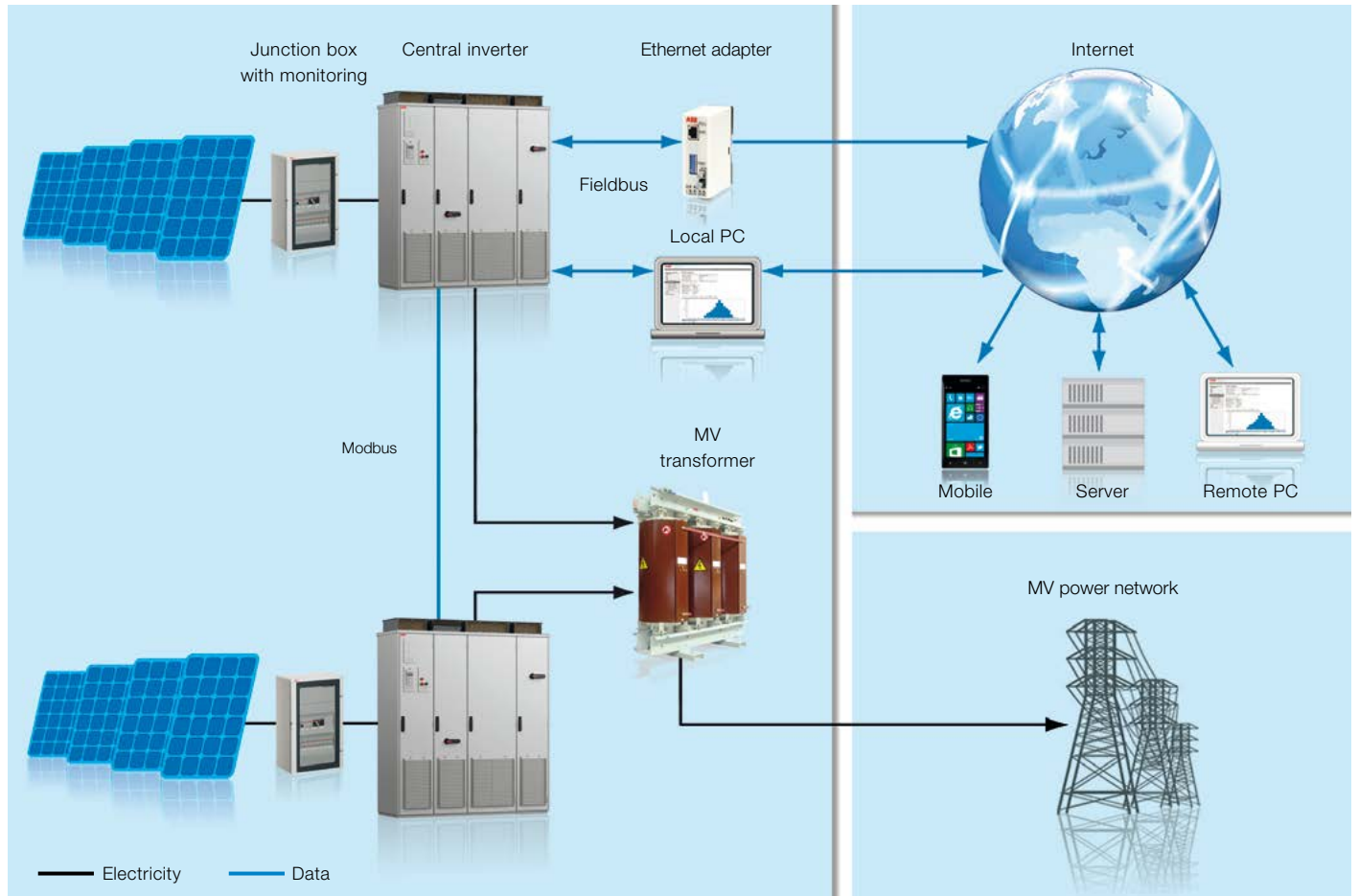

### Options

- Integrated and flexible DC input extension cabinets
- Cabinet heating
- I/O extensions
- DC grounding (negative and positive)
- Fieldbus and Ethernet connections
- Current measurement to each DC input
- Warranty extensions
- Solar inverter care contracts

### Accessories

- Solar array junction boxes with string monitoring
- Remote monitoring solutions