



3-Phase



TTL
inverter
series

- colour graphic touch screen
- integrated data logger
- multi-inverter ready
- indoor / outdoor use (IP65)

TTL inverters: the future is here

advanced technology

These advanced inverters offer superior performance and a lightweight, transformerless design.

TTL inverters deliver over **98% efficiency**.



universal communication

TTL inverters are equipped with **built-in data logger** to record field operating data. Recorded data can be copied quickly and easily to a **USB** memory stick.

In the PV fields with more inverters, all TTL can be linked together via an optional communication device. In this way it is possible working from the user panel of any of the connected inverters, display data of the entire PV field.

Selco Energy has developed a complete and advanced monitoring system that calculates and transmits essential information to the user, using the powerful data loggers integrated in all Selco Energy inverters.

The Selco Energy monitoring system is available in two versions, **EnergyWebMonitor®** and **EnergyWebGuard®**.

Data transmission over LAN/ETHERNET, Wi-Fi and GPRS connections.



all the energy is for you

TTL inverters have been developed using carefully selected technical solutions to guarantee excellent efficiency from a lightweight, compact package. A **wide string voltage range** and Selco Energy new **SmartTrack** algorithm allow TTL inverters to carry on functioning at full power even in poor sunlight. TTL inverters are equipped with **2 MPPT trackers**. This makes PV field configuration as flexible as possible by permitting strings to be set up with different azimuths, tilts and dimensions.



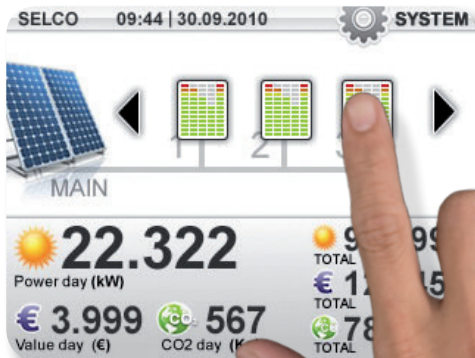

One_Touch interface

The user interface of TTL inverters is provided by a generous 3.5 inch **touch screen display** with clear and intuitive graphics. This display lets you read operating data clearly, and set parameters quickly and easily. A simple touch is enough to activate it even in zero sunlight conditions.

Three signalling LEDs provide a rapid read-out of the inverter's functioning status.

watch the video 
youtube.com/selcoenergy

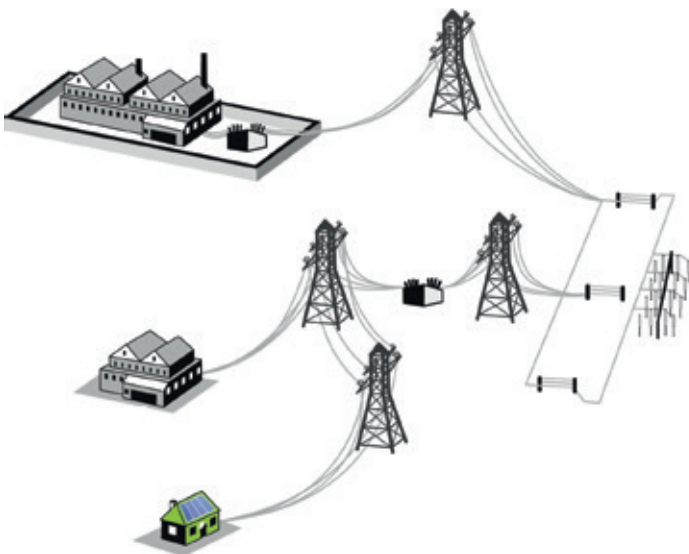

Smart Grid ready

TTL inverters are designed and made in conformity with the European Standards **VDE 0126**, **AR-N 4105**, **EN 50438**, **G83-2** and **G59-2**. These standards are binding on all new installations and demand a hardware and software architecture with provision for connection to smart grids.



SolarPlan

SolarPlan is a software tool developed by Selco Energy to ensure perfect integration between inverters and their photovoltaic fields, and to optimise overall system efficiency.

Though simple to use, SolarPlan is an extremely effective tool for designers and installers configuring PV systems of all sizes, from small domestic systems to large parks. An easy to use and intuitive menu lets you configure systems in 3 simple steps.

Informative messages guide you through every stage of the process.

	TTL 620	TTL 820
Inputs (DC)		
Maximum power	6,6 kW	8,8 kW
Nominal power	6,6 kW	8,8 kW
Maximum voltage	1000 V	1000 V
MPPT voltage range	250 V – 800 V	250 V – 800 V
Start input voltage	200 V	200 V
Maximum power per MPPT	3,9 kW	5,2 kW
Maximum power per MPPT - Unbalanced operation	3,9 kW MPP T1 / 2,7 kW MPPT2	5,2 kW MPP T1 / 3,6 kW MPPT2
Maximum input current (per MPPT)	15,0 A	17,3 A
Number of MPPT trackers	2	2
Maximum number of strings	2 MPP T1 / 2 MPPT2	2 MPP T1 / 2 MPPT2
Outputs (AC)		
Grid connection	Three-phase (Δ/Y)	Three-phase (Δ/Y)
Rated power	6,0 KVA	8,0 KVA
Maximum power	6,0 KVA	8,4 KVA
Nominal voltage range	340... 460 Vac	340... 460 Vac
Maximum output current	8,7 A	12,1 A
Grid frequency	50 Hz	50 Hz
Cos ϕ	> 0,995 (adj \pm 0,80)	> 0,995 (adj \pm 0,80)
Efficiency		
Maximum efficiency	98,0 %	98,2 %
European efficiency	97,8 %	97,9 %
Start feeding-in power	10 W	10 W
Protections		
DC reverse polarity	●	●
Integrated RCMU	●	●
AC short circuit protection	●	●
Oversvoltage category (input/output)	II / III	II / III
Safety class	I	I
Ground fault monitoring	●	●
DC load-disconnecting switch	–	–
Input fuses	–	–
Equipment		
DC connection (quick)	●	●
AC connection (spring clamp)	●	●
Interface (USB/Ethernet/GPRS/CAN-BUS / RS485)	● / ○ / ○ / ○ / ○	● / ○ / ○ / ○ / ○
Touch screen graphic display 3.5"	●	●
Auxiliary relay	●	●
Energy Controller (on-site consumption management)	●	●
General data		
Ambient operating temperature	-25 °C ... +60 °C	-25 °C ... +60 °C
Noise emissions	< 35 dB	< 35 dB
Enclosure Protection Rating	IP 65	IP 65
Installation	Indoor/Outdoor	Indoor/Outdoor
Warranty and certificates		
Duration (10 / 15 / 20 years)	● / ○ / ○	● / ○ / ○
Certificates and approvals		
● standard / ○ optional / – not available		

TTL1020	TTL1220	TTL1520	TTL 1820
11,0 kW	13,2 kW	16,5 kW	19,8 kW
11,0 kW	13,0 kW	16,0 kW	19,0 kW
1000 V	1000 V	1000 V	1000 V
250 V – 800 V	300 V – 800 V	350 V – 800 V	400 V – 800 V
200 V	200 V	200 V	200 V
6,5 kW	7,8 kW	10 kW	10 kW
6,0 kW MPP T1 / 5,0 kW MPPT2	7,8 kW MPP T1 / 5,4 kW MPPT2	10,0 kW MPPT1 / 6,5 kW MPPT2	11,7 kW MPPT1 / 8,1 kW MPPT2
18,6 A	19,5 A	25,0 A	25,0 A
2	2	2	2
2 MPP T1 / 3 MPPT2	2 MPP T1 / 3 MPPT2	3 MPPT1 / 3 MPPT2	3 MPPT1 / 3 MPPT2
Three-phase (Δ/Y)	Three-phase (Δ/Y)	Three-phase (Δ/Y)	Three-phase (Δ/Y)
10,0 KVA	12,0 KVA	15,0 KVA	18,0 KVA
10,5 KVA	12,6 KVA	15,8 KVA	19,0 KVA
340... 460 Vac	340... 460 Vac	340... 460 Vac	340... 460 Vac
15,2 A	18,3 A	22,8 A	27,4 A
50 Hz	50 Hz	50 Hz	50 Hz
> 0,995 (adj ± 0,80)	> 0,995 (adj ± 0,80)	> 0,995 (adj ± 0,80)	> 0,995 (adj ± 0,80)
98,3 %	98,3 %	98,5 %	98,6 %
98,0 %	98,0 %	98,2 %	98,3 %
10 W	10 W	10 W	10 W
●	●	●	●
●	●	●	●
●	●	●	●
II / III	II / III	II / III	II / III
I	I	I	I
●	●	●	●
–	–	–	–
–	–	–	–
●	●	●	●
●	●	●	●
● / ○ / ○ / ○ / ○	● / ○ / ○ / ○ / ○	● / ○ / ○ / ○ / ○	● / ○ / ○ / ○ / ○
●	●	●	●
●	●	●	●
●	●	●	●
-25 °C ... +60 °C	-25 °C ... +60 °C	-25 °C ... +60 °C	-25 °C ... +60 °C
< 35 dB	< 35 dB	< 35 dB	< 35 dB
IP 65	IP 65	IP 65	IP 65
Indoor/Outdoor	Indoor/Outdoor	Indoor/Outdoor	Indoor/Outdoor
● / ○ / ○	● / ○ / ○	● / ○ / ○	● / ○ / ○
CE / CEI 0-16 / CEI 0-21 / VDE 0126-1-1 / AR-N 4105 / EN 50438 / G83-2 / G59-2			

100% Made in Selco

Selco Energy is committed to manufacturing according to the standards of 100% "Made in" certification. Selco Energy's manufacturing process is certified by the prestigious Institute for the Protection of Italian Manufacturers (ITPI).

Selco Energy is committed to combining Italian competence and creativity in the design and assembly processes with the use of components from highly competent local suppliers who have grown along with the Selco brand in 30 years of activity. This strategic choice guarantees a top quality production process that generates technically reliable, efficient and high performance products.



quality and robustness

Selco Energy has carefully selected the materials of the inverter casing to ensure long term reliability under all ambient conditions. TTL inverters have an **protection rating IP65** and are therefore suited to **indoor or outdoor** use.

All TTL inverters can be equipped with an integrated DC disconnecting switch on request.

	TTL 620 / 820 / 1020	TTL 1220 / 1520 / 1820
W mm	373	452
H mm	767	767
D mm	231	241
Weight kg	< 25	< 35

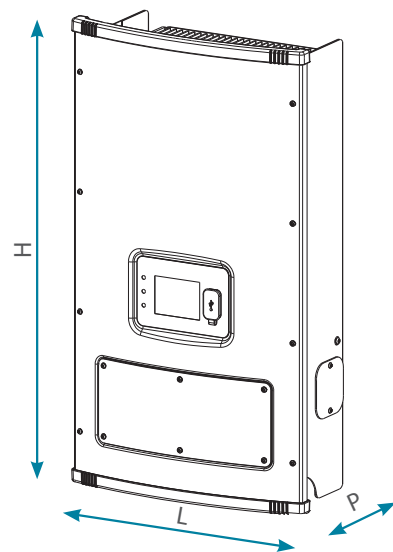

safety and simplicity

TTL inverters are extremely safe to use thanks to a number of integrated protection systems including isolation testing, interface protection, string polarity inversion protection, and AC side short circuit protection. TTL inverters are also equipped with a special, integrated **RCMU** protection device that checks for residual currents. TTL inverters therefore do not need additional class B differential relays to protect them against DC current earth leakage. All TTL inverters are equipped with a protection device that intervenes in the event of a power supply malfunction or overtemperature. TTL inverters come with wall mounting flanges and clearly marked electrical terminals, and are quick and easy to install. They also feature a practical front access panel that provides easy access to internal components without having to remove the outer casing. This makes connection and maintenance operations extremely quick and easy.



selco energy: decades of experience in inverter technology



Selco was set up in the late 1970s

Selco has been manufacturing inverters since its earliest beginnings, first for industrial applications and later for the renewable energy sector. Selco has always pioneered innovative inverter designs and applications, and has often led the way in introducing new technology. Selco has two large, modern factories, both in Italy.



Selco boasts enviable experience in inverter technology

From the outset to the present day, Selco has sold thousands of inverter based systems. Selco puts every effort into the development of innovative solutions that combine functionality and safety, and into the rationalisation and standardisation of components. Selco's ultra-modern electronics R&D centre designs and develops all the software and hardware for Selco products.

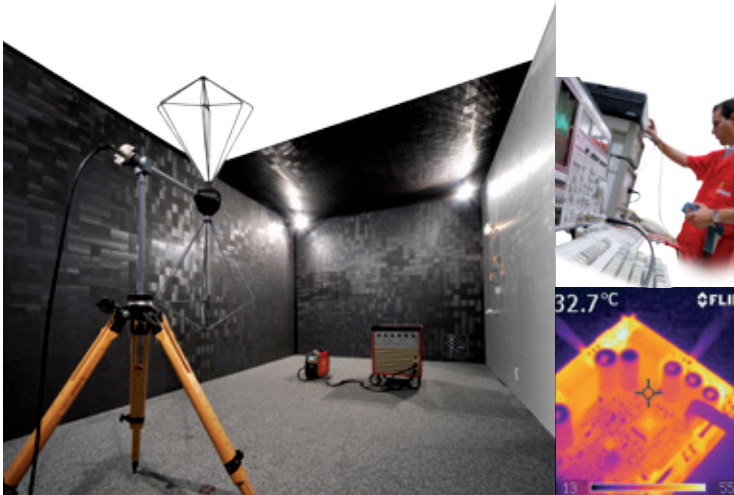

Selco's R&D labs carry out rigorous tests on all new solutions to continually improve product performance

Selco's R&D centre is continuously engaged in the testing of new solutions to improve performance and safety. Selco has registered numerous industrial patents and works hand in hand with university research institutes on the development of innovative technologies.

