

SOLAR INVERTERS

ABB central inverters

PVS800-57B – 1645 to 1732 kW



ABB central inverters raise reliability, efficiency and ease of installation to new levels. The inverters are aimed at system integrators and end users who require high performance solar inverters for large photovoltaic (PV) power plants. The inverters are available up to 1732 kW nominal rating, with 2078 kW output power at lower temperatures.

—
01

—
01 ABB central inverter,
PVS800-57B

World's leading inverter platform

The ABB central inverters have been developed on the basis of decades of experience in the industry and proven technology platform. Unrivalled expertise from the world's market and technology leader in frequency converters is the hallmark of this solar inverter series.

Based on ABB's highly successful platform and the most widely used frequency converters on the market – the inverters are the most efficient and cost-effective way to convert the direct current (DC) generated by solar modules into high-quality and CO₂-free alternating current (AC) that can be fed into the power distribution network.

Solar inverters from ABB

ABB central inverters are ideal for large PV power plants but are also suitable for large-sized power plants installed in commercial or industrial buildings. High efficiency, proven components, compact and modular design and a host of life cycle services ensures ABB central inverters provide a rapid return on investment.

Highlights

- High total performance
- Modular and compact product design
- Extensive DC and AC side protection
- Full grid support functionality
- Fast and easy installation
- Complete range of industrial-type data communication options, including remote monitoring
- Life cycle service and support through ABB's extensive global service network



02

Maximize yields without losing a watt

02 ABB inverter station, PVS800-IS, with two PVS800-57B central inverters and ABB medium voltage pad mounted solution, PVS800-MVP, installed on site

Maximum energy and feed-in revenues

ABB central inverters have a high total efficiency level. Optimized and accurate system control and a maximum power point tracking (MPPT) algorithm together with high efficiency power converter design ensure that maximum energy is delivered to the power distribution network from the PV modules. For end users this generates the highest possible revenues from the feed-in tariffs.

Proven ABB components

The inverters comprise proven ABB components with a long track record of performance excellence in demanding applications and harsh environments. Equipped with extensive electrical and mechanical protection, the inverters are engineered to provide a long and reliable service life of at least 20 years.

Compact and modular design

The inverters are designed for fast and easy installation. The industrial design and modular platform provides a wide range of options like remote monitoring, fieldbus connection and modular and flexible DC input cabinet. The integrated DC cabinet saves space and costs as the solar array junction boxes can be connected directly to the inverter DC cabinet fused busbars. The inverters are customized to meet end user needs and are available with short delivery times.

Effective connectivity to power distribution network

ABB's transformerless central inverter series enables system integrators to design the PV power plant using optimum combination of different power rating inverters. Inverters are connected to the medium voltage (MV) power distribution network either centrally or in a distributed manner depending on the plant size and shape and network connection position.

Advanced grid support features

ABB central inverter software includes all the latest grid support and monitoring features including active power limitation, low voltage ride through (LVRT) with current feed-in and reactive power control. Active and reactive power output can be limited by using an external source. Active power can also be limited automatically as a function of grid frequency.

All grid support functions are parameterized allowing easy adjusting for local utility requirements. ABB central inverters are also able to support grid stability even at night by providing reactive power with the DC input disconnected.

ABB central inverters

PVS800-57B – 1645 to 1732 kW



03

03 ABB central inverter,
PVS800-57B,
doors opened

High total performance

- High power density with small footprint
- Low auxiliary power consumption
- Efficient maximum power point tracking
- Long and reliable service life of at least 20 years

Full grid support functionality

- Reactive power compensation also during the night time
- Active power limitation
- Low voltage ride through with current feed in

Grid code compatibility

- Wide country-specific grid code compliance
- Adjustability to various local utility requirements

Life cycle service and support

- ABB's extensive global service network
- Extended warranties
- Service contracts
- Technical support throughout the service life

Modular industrial design

- Compact and easy-to-maintain product design
- Fast and easy installation
- Integrated and flexible DC input cabinet

Extensive protections

- DC and AC side protection with built-in fuses, surge protection and filters
- Increased reliability and safety with DC and AC side contactors
- Heavy-duty surge protection

Proven technology

- Based on ABB's market-leading technology platform used in frequency converters

Wide communication options

- Complete range of industrial data communication options
- Ethernet/Internet Protocol
- Remote monitoring

ABB central inverters

PVS800-57B – 1645 to 1732 kW



Technical data and types

Type designation	PVS800-57B-1645kW-C	PVS800-57B-1732kW-C
Input (DC)		
Maximum input power ($P_{PV, max}$) ¹⁾	2468 kWp	2598 kWp
DC voltage range, mpp ($U_{DC, mpp}$)	550 to 850 V	580 to 850 V
Maximum DC voltage ($U_{max(DC)}$)	1000 V	1000 V
Maximum DC current ($I_{max(DC)}$)	3700 A	3700 A
Number of protected DC inputs	16 to 24	16 to 24
Output (AC)		
Nominal power ($P_{N(AC)}$) ²⁾	1645 kW	1732 kW
Maximum output power ³⁾	1975 kW	2078 kW
Power at $\cos(\varphi) = 0.95$ ²⁾	1562 kW	1645 kW
Nominal AC current ($I_{N(AC)}$)	2500 A	2500 A
Nominal output voltage ($U_{N(AC)}$) ⁴⁾	380 V	400 V
Output frequency	50/60 Hz	50/60 Hz
Harmonic distortion, current ⁵⁾	< 3%	< 3%
Distribution network type ⁶⁾	TN and IT	TN and IT
Efficiency		
Maximum ⁷⁾	98.5%	98.5%
Euro-eta ⁷⁾	98.3%	98.4%
Power consumption		
Own consumption in operation	1800 W	1800 W
Standby operation consumption	60 W	60 W
External auxiliary voltage	400 V	400 V
Dimensions and weight		
Width/Height/Depth, mm (W/H/D)	4030/2150/720	4030/2150/720
Weight appr. ⁸⁾	3000 kg	3000 kg

¹⁾ Recommended maximum input power
²⁾ At 50 °C. See the user manual for details.
³⁾ At 25 °C. See the user manual for details.
⁴⁾ +/- 10%
⁵⁾ At nominal power

⁶⁾ Inverter side must be IT type
⁷⁾ Without auxiliary power consumption at min U_{DC}
⁸⁾ For the smallest number of protected inputs. See the user manual for details.

ABB central inverter design and power network connection

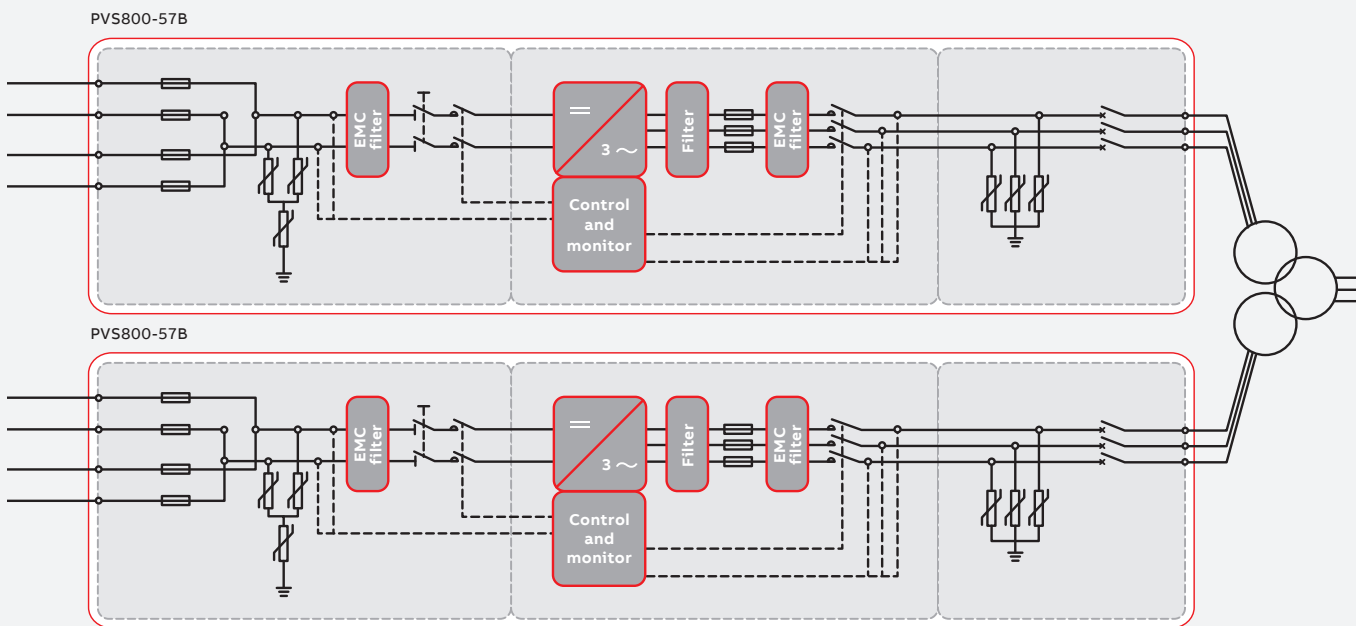

Technical data and types

Type designation	PVS800-57B-1645kW-C	PVS800-57B-1732kW-C
Environmental limits		
Degree of protection	IP41	IP41
Ambient temp. range (nom. ratings) ⁹⁾	-20 to +50 °C	-20 to +50 °C
Maximum ambient temperature ¹⁰⁾	+60 °C	+60 °C
Relative humidity, not condensing	15 to 95%	15 to 95%
Maximum altitude (above sea level) ¹¹⁾	3000 m	3000 m
Maximum noise level ¹²⁾	< 75 dBA	< 75 dBA
Maximum air flow	10200 m ³ /h	10200 m ³ /h
Protection		
Ground fault monitoring	Yes	Yes
Grid monitoring	Yes	Yes
Anti-islanding	Yes	Yes
DC reverse polarity	Yes	Yes
AC and DC short circuit and over current	Yes	Yes
AC and DC over voltage and temperature	Yes	Yes
User interface and communications		
Local user interface	ABB local control panel	
Analog inputs/outputs	Extendable as option	
Digital inputs/relay outputs	Extendable as option	
Fieldbus connectivity	Modbus, Profinet, Ethernet	
Product compliance		
Safety and EMC	CE conformity according to LV and EMC directives	
Certifications and approvals ¹³⁾	CEA, CEI 0-16	
Grid support and grid functions	Reactive power compensation ¹⁴⁾ , FRT, Anti-islanding	

⁹⁾ Frosting is not allowed. May need optional cabinet heating.

¹⁰⁾ Power derating after 50 °C

¹¹⁾ Power derating above 1000 m

¹²⁾ At five meters

¹³⁾ More detailed information, please contact ABB

¹⁴⁾ Also during the night

Data communication principle for ABB central inverters

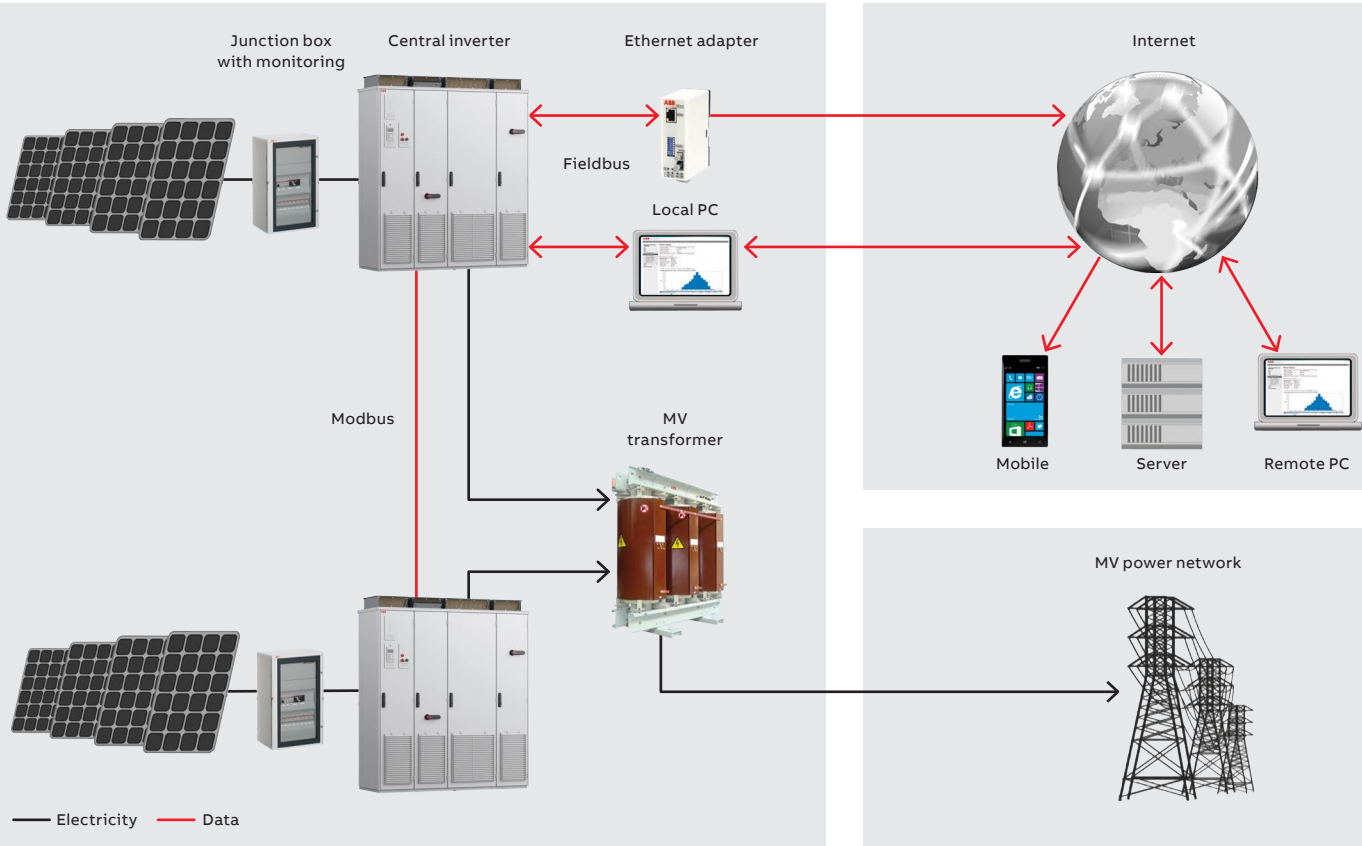

Options

- Integrated and flexible DC input extension cabinets
- Cabinet heating
- I/O extensions
- DC grounding (negative and positive)
- Fieldbus and Ethernet connections
- Current measurement to each DC input
- Warranty extensions
- Solar inverter care contracts

Accessories

- Solar array junction boxes with string monitoring
- Remote monitoring solutions

Support and service

ABB supports its customers with a dedicated service network in more than 60 countries and provides a complete range of life cycle services from installation and commissioning to preventative maintenance, spare parts, repairs and recycling.

For more information please contact your local ABB representative or visit:

www.abb.com/solarinverters
www.abb.com

We reserve the right to make technical changes or modify the contents of this document without prior notice. With regard to purchase orders, the agreed particulars shall prevail. ABB does not accept any responsibility whatsoever for potential errors or possible lack of information in this document.

We reserve all rights in this document and in the subject matter and illustrations contained therein. Any reproduction, disclosure to third parties or utilization of its contents – in whole or in parts – is forbidden without prior written consent of ABB. Copyright © 2018 ABB. All rights reserved

