

EP-5000-HB-UD/20~35, EP-6250-HC-UD/20~35

MV Turnkey Station for 1500V Utility PV Plant



More power generation

Inverter Max. efficiency 99%, Euro efficiency 98.7%
Full power operation without derating at 50 °C
1500Vdc PV system reduce power loss



Low System Cost

Convenient for large block size PV plant
Integrated MV transformer and switchgear
High DC/AC ratio up to 1.5



High Reliability

Capacitor life prediction technology
Key components at front side, easy for maintenance
Current sensor for each DC input, more reliable for monitoring and control



Grid friendly

LVRT and HVRT function
Active & reactive power dispatch

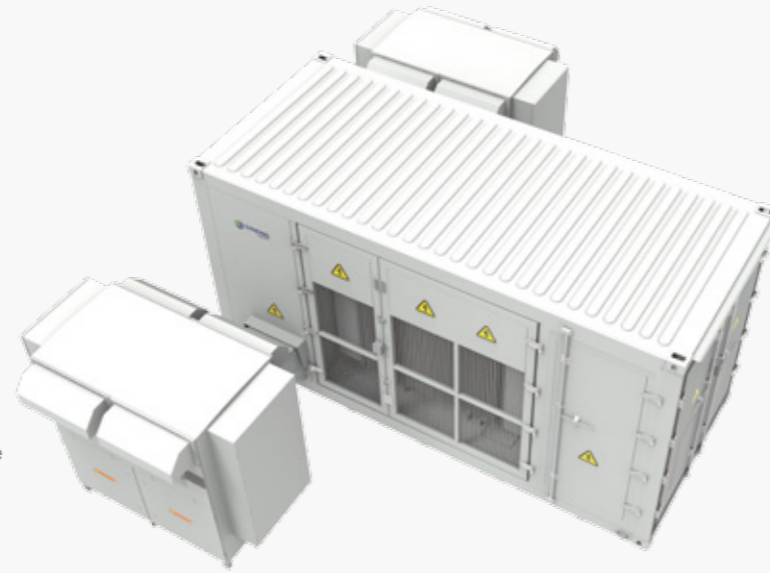

Circuit

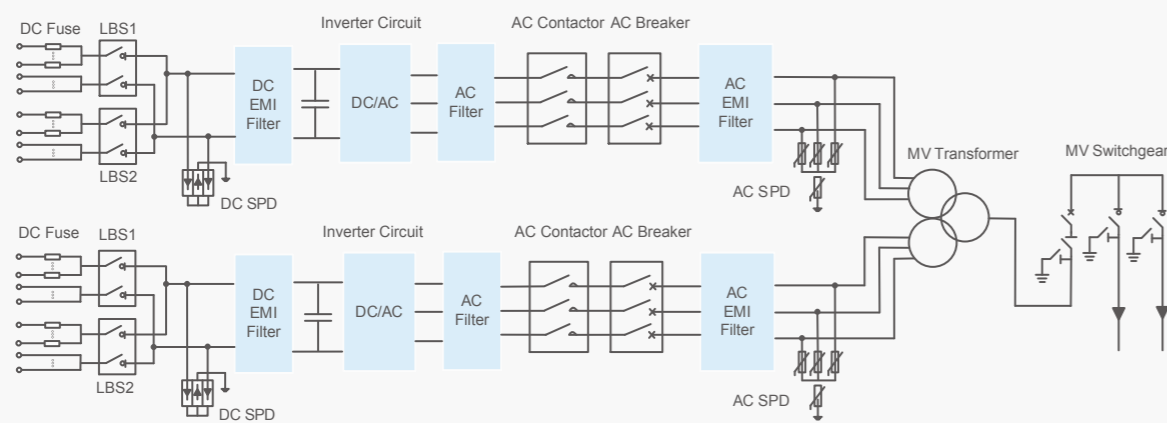

Input (DC)	EP-5000-HB-UD/20~35	EP-6250-HC-UD/20~35
Max. PV input voltage	1500V	1500V
Max. input current	3668A*2	4191A*2
MPP voltage range for nominal power	800~1300V	875~1300V
Number of MPPT trackers	2	2
Number of DC inputs	(14~20)*2	(16~22)*2
Output (AC)		
Rated AC output power(@ 50 °C)	2500kVA*2	3125kVA*2
Max. AC output power(@25 °C)	2875kVA*2	3594kVA*2
AC voltage range	20~35kV	20~35kV
Rated grid frequency/range	50 Hz/ 45~55 Hz, 60Hz/ 55~65 Hz	50 Hz/ 45~55 Hz, 60Hz/ 55~65 Hz
Output current harmonic(at nominal power)	< 3 %	< 3 %
DC current injection	< 0.5% In	< 0.5% In
Power factor at nominal power/range	>0.99/ 0.8 lagging to 0.8 leading	>0.99/ 0.8 lagging to 0.8 leading
Protection		
DC input protection	Load break switch+fuse/Circuit breaker	Load break switch+fuse/Circuit breaker
AC output protection	Circuit breaker	Circuit breaker
AC MV output protection	Circuit breaker/Load break switch+fuse	Circuit breaker/Load break switch+fuse
Overvoltage protection	DC Type II / AC Type II	DC Type II / AC Type II
Leakage current monitoring	Yes	Yes
Grid monitoring/Ground fault monitoring	Yes/Yes	Yes/Yes
Insulation monitoring	Yes	Yes
Overheat protection	Yes	Yes
Night SVG function	Optional	Optional
Anti-PID function	Optional	Optional
Efficiency		
Inverter Max. efficiency	99.00%	99.00%
Inverter EU efficiency	98.70%	98.70%
Transformer		
Transformer Rated power	5000 kVA	6250 kVA
Transformer Max. power	5750 kVA	7188 kVA
LV / MV Voltage	0.55-0.55/20~35kV	0.6-0.6/20~35kV
Transformer Vector	Dy11y11	Dy11y11
Transformer cooling type	ONAN (Oil Natural Air Natural)	ONAN (Oil Natural Air Natural)
General data		
Weight	25t	25t
Protection level	Inverter:IP65, Others:IP54	Inverter:IP65, Others:IP54
Auxiliary power supply	Standard: 10kVA, Optional: max.40kVA	Standard: 10kVA, Optional: max.40kVA
Temperature	- 30 ~ +60 °C (>50 °C derating)	- 30 ~ +60 °C (>50 °C derating)
Allowed humidity(non condensing)	0 - 95 %	0 - 95 %
Cooling mode	Temperature controlled forced air cooling	Temperature controlled forced air cooling
Max.operating altitude	2000m(standard) / > 2000m(optional)	2000m(standard) / > 2000m (optional)
Display	LCD	LCD
Communication port	RS485/Ethernet	RS485/Ethernet