



# NP100-12G (12V100Ah/10hr)



NPG Series is GEL battery which is manufactured with AGM separator and colloidal Silicon. Gel battery are featured with low self-discharge, strong ability to recover from deep discharging, excellent cycle life and performance at cold ambient temperatures than conventional VRLA

## Battery Construction

Component	Positive plate	Negative plate	Container	Cover	Safety valve	Terminal	Separator	Electrolyte
Raw material	Lead dioxide	Lead	ABS	ABS	Rubber	Copper	Fiberglass	Colloidal silicon

## General Feature

- Micro millimeter SiO<sub>2</sub> and H<sub>2</sub>SO<sub>4</sub> technology for Efficient gas recombination of up to 99% and Freedom from electrolyte maintenance or water adding.
- Not restricted for air transport-complies with IATA/ICAO Special Provision A67.
- UL-recognized component.
- Can be mounted in any orientation.
- Computer designed lead, calcium tin alloy grid for high power density.
- Long service life, float or cyclic applications.
- Maintenance-free operation.
- Low self discharge.

## SPECIFICATION

Nominal voltage ..... 12V  
 Number of cell ..... 6  
 Length(mm/inch) ..... 328/12.9  
 Width(mm/inch) ..... 171/6.73  
 Height(mm/inch) ..... 214/8.43  
 Total Height(mm/inch) ..... 218/8.58  
 Approx. Weight(kg/lbs) .....28.5/62.7

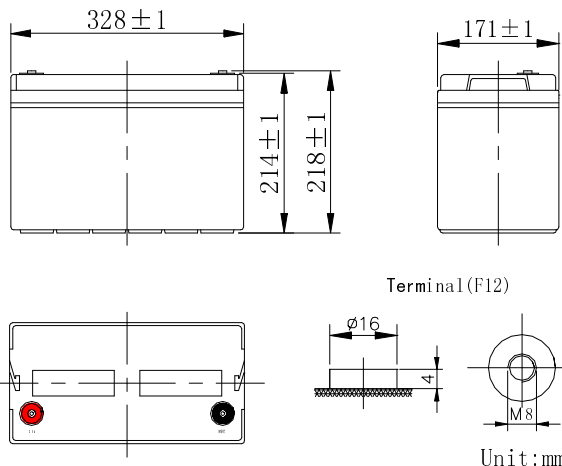

## Performance Characteristics

Capacity 77°F(25°C)	100 hour rate (1.1A、11.1V)	110Ah
	20 hour rate (5A、10.5V)	100Ah
	10 hour rate (9.2A、10.5V)	92Ah
	1 hour rate (58A、9.6V)	58Ah
Internal Resistance	Full charged Battery 77°F(25°C): 10mΩ	
Operating Temperature Range	Discharge: -20~60°C	
	Charge: -10~60°C	
	Storage: -20~60°C	
Self-Discharge 3% of capacity declined per month at 20°C(average)		
Max. discharge current 77°F(25°C): 800A(5S)		
Charge (Constant Voltage)	Float: 13.38~13.68 V/77° F(25°C)	
	Cycle: 14.28~14.52 V/77°F(25°C) Max. Current: 25A	

Discharge Constant Current (Amperes at 77° F 25 °C)

End Point Volts/Cell	5min	10min	15min	30min	1h	3h	5h	10h	20h
1.60V	292	200	164	92.9	58.0	25.2	16.8	9.40	5.25
1.65V	267	187	156	89.3	56.4	25.0	16.6	9.30	5.15
1.70V	245	172	148	86.6	54.5	24.8	16.5	9.20	5.10
1.75V	218	162	138	84.0	53.7	24.6	16.3	9.20	5.00
1.80V	193	148	129	82.2	52.7	24.5	16.0	9.10	4.95

Discharge Constant Power (watts at 77° F 25 °C)

End Point Volts/Cell	5min	10min	15min	30min	45min	1h	2h	3h	5h
1.60V	501	346	283	177	131	113	64.8	46.0	32.5
1.65V	457	328	278	171	127	111	63.7	45.3	32.3
1.70V		312	270	167	125	110	62.5	44.9	32.0
1.75V	390	295	259	162	123	106	61.3	44.5	31.9
1.80V	353	275	251	156	120	103	60.7	43.6	31.6

(Note) The above characteristics data are average values obtained Within three charge/discharge cycles not the minimum values.

