

R27515 TL

132.446.050



MAXIMUM EFFICIENCY

98.9 %

OUTPUT VOLTAGE

550 V_{AC} ± 10%

MPPT VOLTAGE RANGE

930 - 1.450 V_{DC}

Advantage

- > High efficiency, up to 99%.
- > Modular inverter (MPS system).
- > Elevato rendimento, fino a 99%.
- > Modularità dell'inverter (MPS system).

Features

- > Use of a single magnetic component each module.
- > Advance modulation (according to IPCCM algorithm).
- > Continuous monitoring of the system and integrated datalogger.
- > Outbound communication.
- > Monitoring of the photovoltaic plant.
- > Impiego di un singolo componente magnetico per ciascun modulo.
- > Modulazione all'avanguardia (secondo l'algoritmo IPCCM).
- > Supervisione continua del sistema e datalogger integrato.
- > Comunicazione verso il mondo esterno.
- > Monitoraggio dell'impianto fotovoltaico.

Accessories

- > Accessories references - page 81
- > Vedi accessori - pagina 81

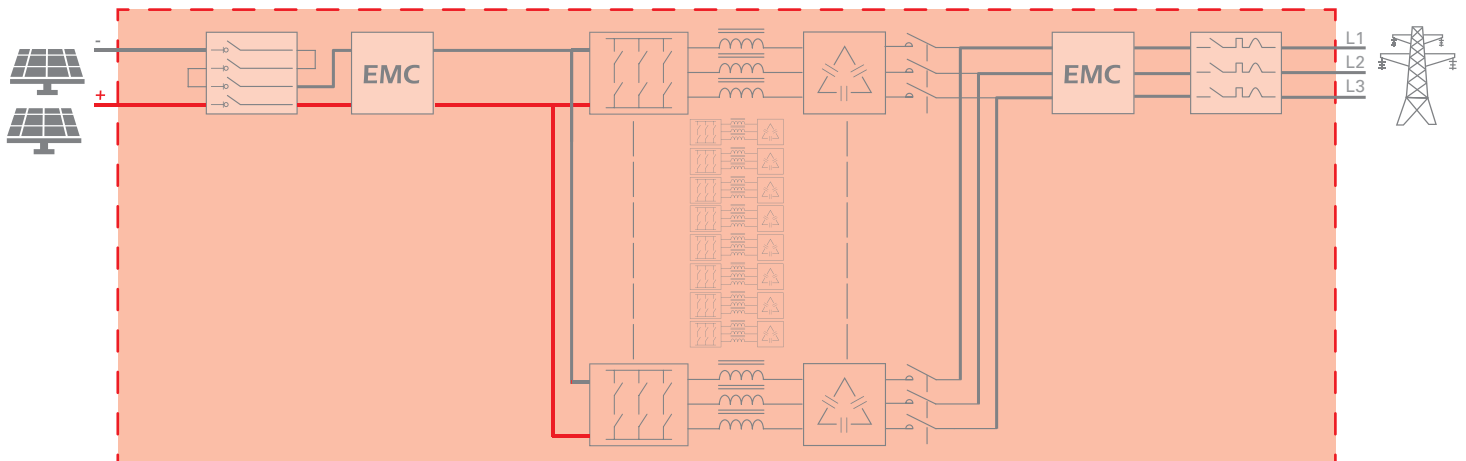
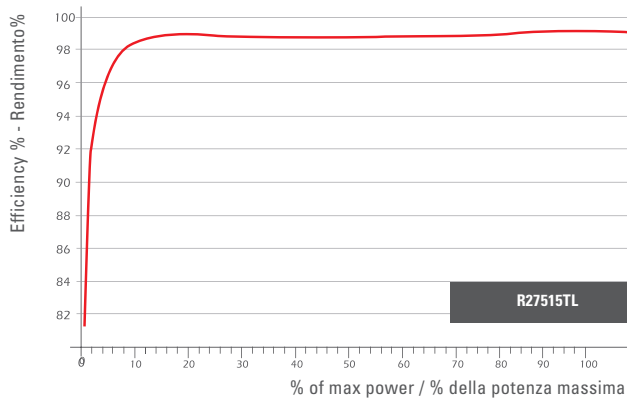
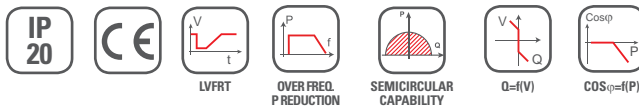

MV Central Inverter

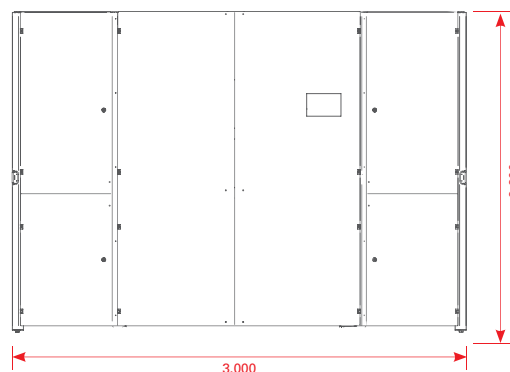
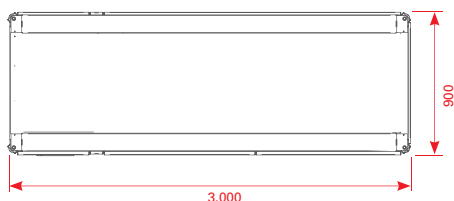
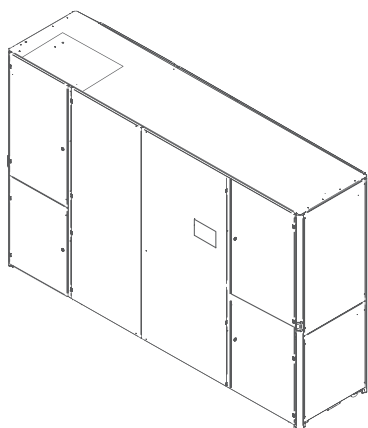

DC Input - PV Module

	R27515TL
MPPT voltage range(V_{DC}) (Note 1)	930 – 1450 V
Absolute max DC voltage (V_{DC})	1.500 V
DC-voltage ripple (%)	<2%
Maximum input current (A_{DC})	3050
DC short circuit current (A_{DC})	3200 A
Voltage Ripple	<2%
Number of MPPT	1
Overvoltage Protection	SPD varistor device Class II (Opt. Class I+II)
DC input connection	DC Switch under load
Reverse Polarity Protection	Yes

AC Output grid

Max Power (kW) (Note 1)	2.750 kW @ 25°C 2.390 kW @ 50°C
Max Apparent Power S_{max} (kVA)	2.750 kVA @ 25°C 2.390 kVA @ 50°C
Maximum Current (A_{AC}) (Note 1)	2.890 A @ 25°C 2.510 A @ 50°C
Max unbalance current	< 2%
AC output Voltage (V_{AC})	550V_{RMS} ±10%
Nr. Phase	3-phase (L1 – L2 – L3 – PE)
Frequency (Hz)	50/60 Hz
Aux. power supply ($V_{AC} - I_{AC}$)	230V ±10% (L-N)
Auxiliary control supply ($V_{AC} - I_{AC}$)	230V ±10% (L-N)
Distortion factor (THDi) (Note 2)	<3%
Power Factor (Note 3)	From 0 to 1 inductive or capacitive
Galvanic insulation	No (transformerless)
AC input connection	Magneto-thermic Circuit Breaker (MCCB)

General Data

Maximum efficiency	98.90%
European efficiency	98.62%
Night consumption (W)	< 60 W
Weight (kg)	2.500 kg approx.
Protection degree	IP20
Cooling	Air forced cooling fan speed controlled
Dimensions (W x D x H)	3.000x900x2.200 mm
Noise level (dBA)	< 70 dBA
Operating temperature (°C) (Note 4)	-10° C +55° C
Storage temperature (°C)	-20° C +60° C
Humidity (Not condensing) (%)	0 ± 95%
Height above the sea (without derating) (Note 5)	1.000 m
Air Flow	5.820 m³/h
Overvoltage Category	II
Color	RAL 9006

Note 1: Power factor (cosφ)= 1 and Vac nominal.
Note 2: THDi is lower than 3% for inverter power greater than 25%.
Note 3: P-Q capability is semicircular with radius equal to S_{max} for all MPPT range.
Note 4: Linear derating to 0 kVA from 50°C to 55°C.
Note 5: Above 1.500m a.s.l. derating of the power of 1% per 100m.

Note: Each inverter must be connected separately to its own LV/MV transformer or it has to be connected to a separate LV secondary input of the LV/MV transformer. Two or more inverters cannot be connected in parallel to the same LV secondary input of the LV/MV transformer.