

ASTORIOS

per aspera ad astra

BIFACIAL, DOUBLE GLASS PHOTOVOLTAIC MODULE

ASTR 110HCD/12 Series 535-555 Wp

HALF CUT PERC CELLS

555 Wp
MAXIMUM POWER OUTPUT

21.2 %
MAXIMUM MODULE EFFICIENCY



MORE YIELD

PV modules are positive tolerance current level sorted bringing to increase in energy yield and avoiding solar panel degradation due to mismatch.



HOT SPOTS RISK REDUCTION

Sophisticated electrical design, cells sorting, cutting and soldering technology leads to low hot spot risk and temperature control



HIGH QUALITY GLASS

Additional yield and easy maintenance are provided by high transparent and self-cleaning glass



MULTI BUSBAR TECHNOLOGY

Better light absorption and current collection for better power output



MINIMIZING THE SHADING IMPACT

Better partial-shade tolerance due to separated half panel string wiring



PID RESISTANT

Selected encapsulants, precision in manufacturing quality control makes modules highly PID resistant and snail trails free



SAND, AMMONIA AND SALT MIST RESISTANCE

Sand blowing, ammonia and salt mist resistance tests have been passed by international standards to ensure operation in harsh conditions



SUPERIOR SAFETY AND RELIABILITY

Tested to avoid microcracks and welding cracks, can withstand high pressure loads, passed multi-step quality control

PERFORMANCE

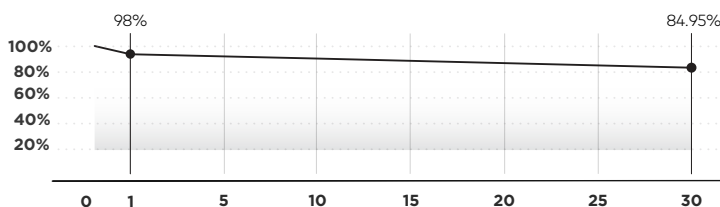

30 YEARS
Performance Guarantee

15 YEARS
Product Warranty

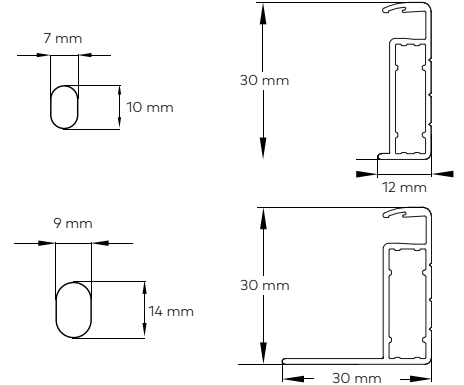
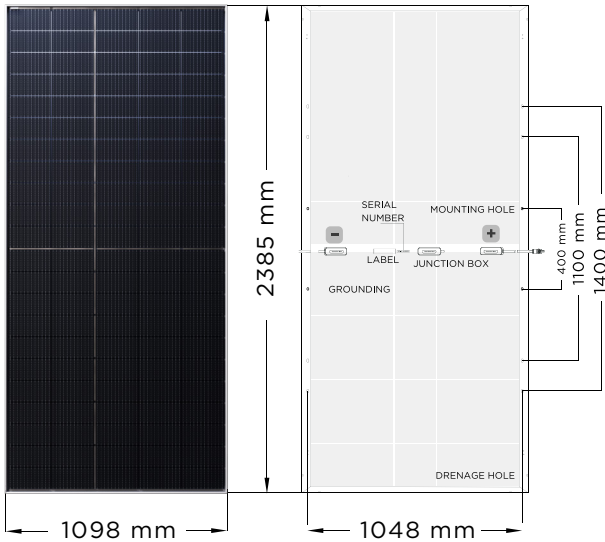

MATERIAL CHARACTERISTICS

Dimensions	2385 x 1098 x 30 mm
Weight	32.6 kg
Number of cells	110 pcs (5x22)
Cells	Bifacial, Half Cut PERC 12BB (210 mm)
Bifaciality	70±5%
Glass front/back	2 mm AR coated tempered glass, low iron
Frame	Silver color, Anodized aluminum alloy
Junction box	IP68, 3 diodes
Connector type	Staubli MC4-Evo 2 / MC4 (Original)
Cable	4 mm ² , 300 mm

PACKAGING INFORMATION

One pallet quantity	620 pcs
Module Per Box	31 pcs

TEMPERATURE PARAMETERS

Temperature Coefficient of Pmax	-0.34 % / °C
Temperature Coefficient of Voc	-0.25 % / °C
Temperature Coefficient of Isc	+0.04 % / °C
Operating Temperature	-40°C to +85 °C
Normal Operating Cell Temperature (NOCT)	43±2°C

MAXIMUM RATINGS

Max. System Voltage	1500V DC -(H)
Max. Series Fuse Rating	35A
Uplift load (wind)	2400 Pa*
Downforce load (snow)	5400 Pa*

*For more information please refer to Instruction Manual

MODULE TYPE	110HCD/12		535 Wp		540 Wp		545 Wp		550 Wp		555 Wp	
	STC	NMOT	STC	NMOT	STC	NMOT	STC	NMOT	STC	NMOT	STC	NMOT
ELECTRICAL CHARACTERISTICS												
Maximum power (Pmax / Wp)	535	405	540	409	545	413	550	417	555	420		
Open circuit voltage (Voc / V)	37.3	35.1	37.5	35.3	37.7	35.5	37.9	35.7	38.1	35.9		
Short circuit current (Isc / A)	18.36	14.80	18.41	14.84	18.47	14.88	18.52	14.92	18.56	14.96		
Maximum power voltage (Vmp / V)	31.0	28.8	31.2	29.0	31.4	29.2	31.6	29.4	31.8	29.5		
Maximum power current (Imp / A)	17.28	14.06	17.33	14.10	17.37	14.15	17.40	14.19	17.45	14.23		
Module efficiency at STC (ηm / %)	20.5		20.7		20.9		21.0		21.2			
5%*	Maximum power (Pmax / Wp)	561.7		567.0		572.2		577.5		582.7		
	Module efficiency at STC (ηm / %)	21.45		21.65		21.85		22.05		22.25		
15%*	Maximum power (Pmax / Wp)	615.2		621.0		626.7		632.5		638.2		
	Module efficiency at STC (ηm / %)	23.49		23.71		23.93		24.15		24.37		
25%*	Maximum power (Pmax / Wp)	668.7		675.0		681.2		687.5		693.7		
	Module efficiency at STC (ηm / %)	25.53		25.77		26.01		26.25		26.49		

Power tolerance (Pmax) (0,+5) Wp

STC: Irradiance of 1000 W/m² with spectrum AM 1.5 and a module temperature of 25°C

NMOT: Irradiance 800W/m², ambient temperature 20°C and wind speed 1 m/s

CERTIFICATES

- IEC 62716 (Ammonia)
- IEC 60068-2-68 (Sand)
- IEC 61701 (Salt)
- IEC 61215 / 61730



I-V Curve at Different Temperature (545 W)

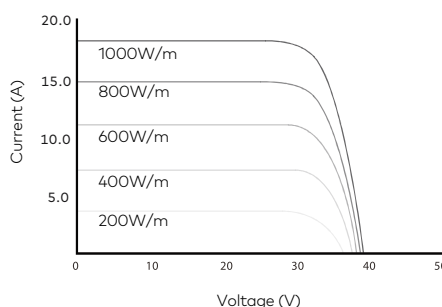

P-V Curve (545 W)

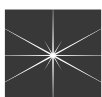
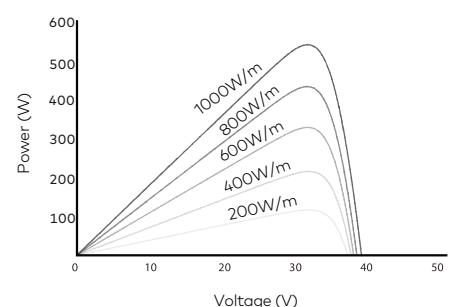

ASTORIOS Holding Inc.
16192 Coastal Highway, Lewes,
Delaware 19958, USA
info@astorios.com