

## 30 Years

Industry Experience

# C1D2 HazLoc Engineered Durability

### ABOUT US

Hub Solar's commitment to engineering excellence are evident in our ruggedized C1D2 family of solar panels. Meeting today's most stringent hazardous location standards, and using the best available materials and technologies.

Our manufacturing facilities are world class and operate in strict accordance to ISO 9001 standards. Our process controls, quality control and flash testing, ensure manufacturing excellence.

## Applications



Offgrid Industrial Sites



Communications Sites



Oil & Gas Sites



Mountain Top



Commercial on Grid



Offshore Sites

### MODULE PERFORMANCE

## HSMH60-330-G1



**330W**  
Max Power



**9.89A**  
Max Power Current

### DETAILS

## Start at the core

- Industrial Grade Design
- Robust Aluminum Frame
- 3.2mm Glass Cover
- Thick Backing Cover
- Factory Installed Leads
- Mono Crystalline Cells
- ISO Standards

## MONO CRYSTALLINE SOLAR MODULE

# HSMH60-330-G1

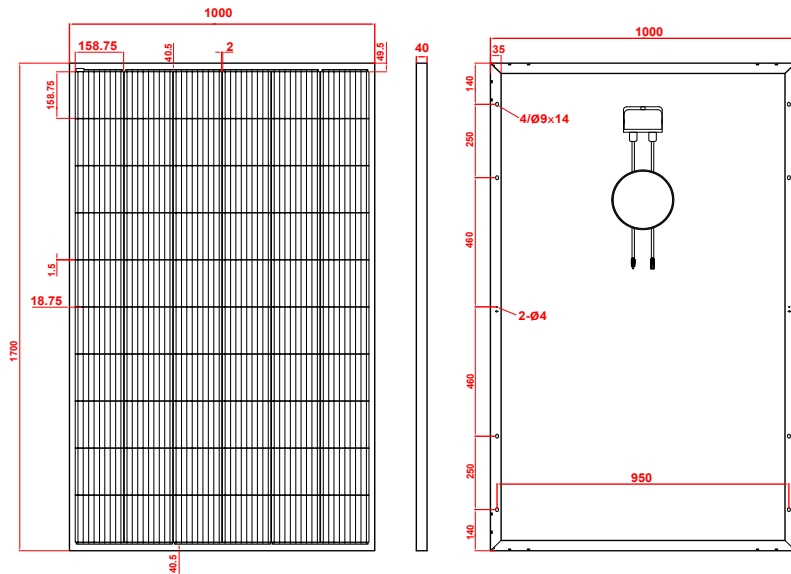

STC: Irradiance 1000 W/m<sup>2</sup>; SpectrumAM1.5; Cell Temperature 25°C, Wind 0 m/s

<b>Type</b>	HSMH60-330-G1
<b>Type of Solar Cell</b>	Mono-crystalline, 158.75mm×158.75mm
<b>Number of Cells</b>	60
<b>Size of module</b>	1660×1000×40mm (158.75×158.75mm cell)
<b>Module, Weight</b>	17.4kg
<b>Connector</b>	Low Profile Junction Box with Wire Leads
<b>Cables</b>	Customizable
<b>Front Cover Glass</b>	Safety Glass
<b>Front Cover Glass, Thickness</b>	3.2 mm
<b>Frame</b>	Anodized Aluminium



## ELECTRICAL DATA

<b>Maximum Power</b>	330W
<b>Power Tolerance</b>	+ 3%
<b>Maximum Power Voltage - Vmp</b>	30.35V
<b>Maximum Power Current - Imp</b>	9.89A
<b>Open Circuit Voltage - Voc</b>	40.80V
<b>Short Circuit Current - Isc</b>	10.50A
<b>Cell Efficiency</b>	22.0%
<b>Maximum System Voltage</b>	1000V

## TEMPERATURE COEFFICIENTS

<b>Power Coefficient</b>	-0.50 ±0.05%/K
<b>Voltage Coefficient</b>	-0.35 ±0.01%/K
<b>Current Coefficient</b>	0.065 ±0.015%/K

## SAFETY STANDARDS & CERTIFICATIONS

- Nonincendive Electrical Equipment for Use in Class I and II, Division 2 and Class III, Divisions 1 and 2  
 Standard(s): Hazardous (Classified) Locations [UL 121201:2017 Ed.9+R:APRIL 1, 2021]
- Nonincendive Electrical Equipment for Use in Class I and II, Division 2 and Class III, Divisions 1 and 2 Hazardous (Classified)  
 Locations [CSA C22.2#213:2017 Ed.3+U1;U2;U3]

IEC 61215, IEC 61730, TUV, CE, ISO9001:200



## WARRANTY

5 years warranty against production and material defects

10 years performance warranty to 90%

25 years performance warranty to 80%