

30 Years

Industry Experience

C1D2 HazLoc Engineered Durability

ABOUT US

Hub Solar's commitment to engineering excellence are evident in our ruggedized C1D2 family of solar panels. Meeting today's most stringent hazardous location standards, and using the best available materials and technologies.

Our manufacturing facilities are world class and operate in strict accordance to ISO 9001 standards. Our process controls, quality control and flash testing, ensure manufacturing excellence.

Applications



Offgrid Industrial Sites



Communications Sites



Oil & Gas Sites



Mountain Top



Commercial on Grid



Offshore Sites

MODULE PERFORMANCE

HSMH36-100-G1



100W
Max Power



4.96A
Max Power Current

DETAILS

Start at the core

- Industrial Grade Design
- Robust Aluminum Frame
- 3.2mm Glass Cover
- Thick Backing Cover
- Factory Installed Leads
- Mono Crystalline Cells
- ISO Standards

MONO CRYSTALLINE SOLAR MODULE

HSMH36-100-G1

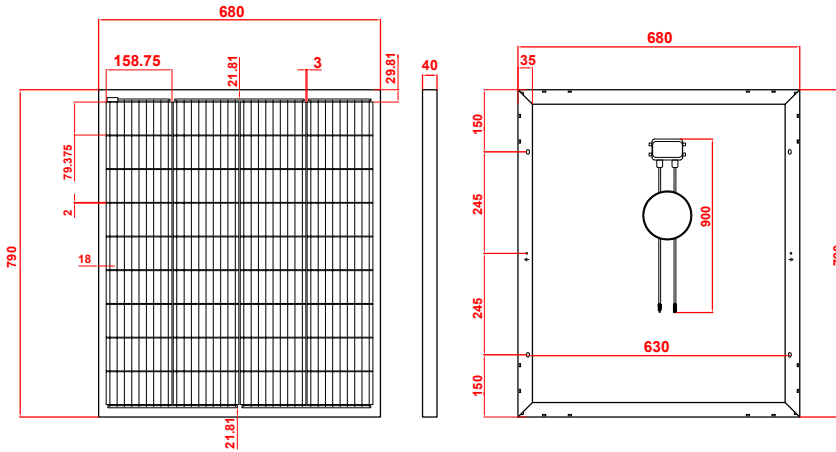

ELECTRICAL DATA

Maximum Power	100W
Power Tolerance	+ 3%
Maximum Power Voltage - Vmp	20.15V
Maximum Power Current - Imp	4.96A
Open Circuit Voltage - Voc	24.55V
Short Circuit Current - Isc	5.25A
Cell Efficiency	22.3%
Maximum System Voltage	1000V

STC: Irradiance 1000 W/m²; SpectrumAM1.5; Cell Temperature 25°C, Wind 0 m/s

Type	HSMH36-100-G1
Type of Solar Cell	Mono-crystalline, 158.75mm×158.75mm
Number of Cells	36
Size of module	790×680×40mm (158.75×79.375mm cell)
Module, Weight	5.6kg
Connector	Low Profile Junction Box with Wire Leads
Cables	Customizable
Front Cover Glass	Safety Glass
Front Cover Glass, Thickness	3.2 mm
Frame	Anodized Aluminium

TEMPERATURE COEFFICIENTS

Power Coefficient	-0.50 ±0.05%/K
Voltage Coefficient	-0.35 ±0.01%/K
Current Coefficient	0.065 ±0.015%/K

SAFETY STANDARDS & CERTIFICATIONS

- Nonincendive Electrical Equipment for Use in Class I and II, Division 2 and Class III, Divisions 1 and 2
 Standard(s): Hazardous (Classified) Locations [UL 121201:2017 Ed.9+R:APRIL 1, 2021]
- Nonincendive Electrical Equipment for Use in Class I and II, Division 2 and Class III, Divisions 1 and 2 Hazardous (Classified)
 Locations [CSA C22.2#213:2017 Ed.3+U1;U2;U3]

IEC 61215, IEC 61730, TUV, CE, ISO9001:200



WARRANTY

5 years warranty against production and material defects

10 years performance warranty to 90%

25 years performance warranty to 80%