



ASTORIOS

per aspera ad astra

HIGH EFFICIENCY BIFACIAL, DOUBLE GLASS PHOTOVOLTAIC MODULE

ASTR 108HCND/10 Series 410-430 Wp

TOPCON N-TYPE HALF CUT CELLS

430 Wp
MAXIMUM POWER OUTPUT

22.02%
MAXIMUM MODULE EFFICIENCY



NEGLIGIBLE LID IMPACT

TOPCon cells exhibit an almost zero susceptibility to Light Induced Degradation, ensuring sustained high efficiency over time despite exposure to sunlight



HOT SPOTS RISK REDUCTION

Sophisticated electrical design, cells sorting, cutting and soldering technology leads to low hot spot risk and temperature control



HIGH EFFICIENCY

N-type cells technology provides the highest efficiency modern multi busbar configuration at affordable cost.



MULTI BUSBAR TECHNOLOGY

Better light absorption and current collection for better power output



MINIMIZING THE SHADING IMPACT

Better partial-shade tolerance due to separated half panel string wiring



PID RESISTANT

Selected encapsulants, precision in manufacturing quality control makes modules highly PID resistant and snail trails free



SAND, AMMONIA AND SALT MIST RESISTANCE

Sand blowing, ammonia and salt mist resistance tests have been passed by international standards to ensure operation in harsh conditions



SUPERIOR SAFETY AND RELIABILITY

Tested to avoid microcracks and welding cracks, can withstand high pressure loads, passed multi-step quality control

PERFORMANCE

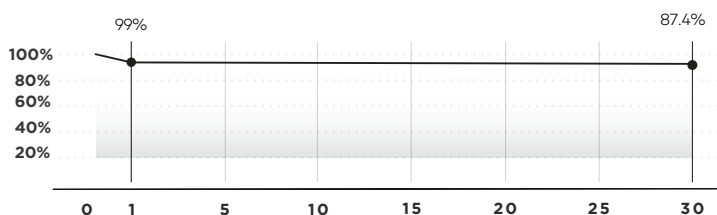

30 YEARS
Performance Guarantee

20 YEARS
Product Warranty

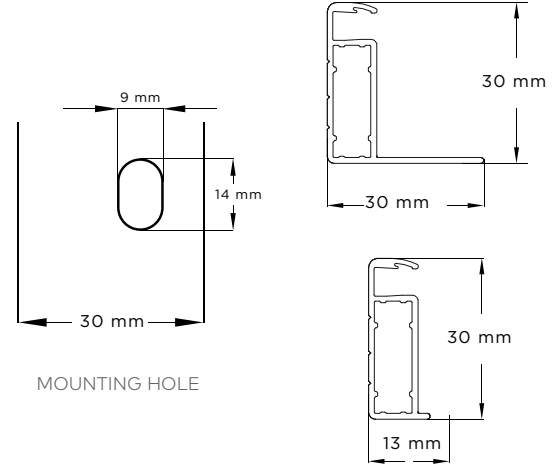
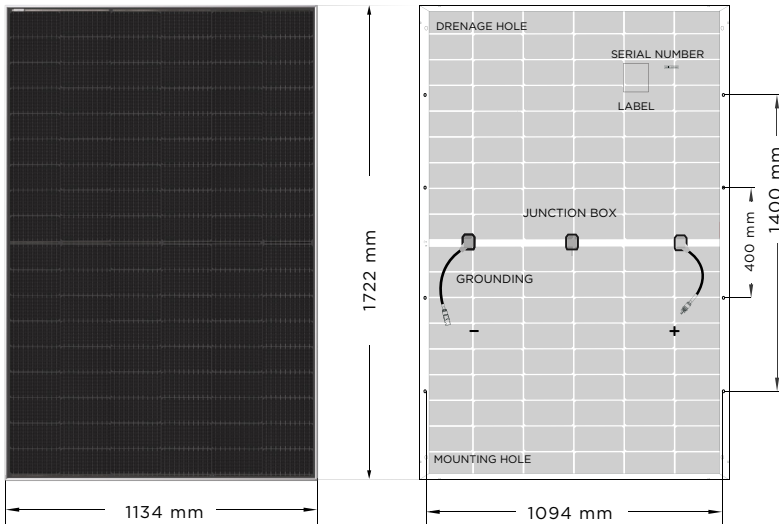

FRAME PROFILE

MATERIAL CHARACTERISTICS

Dimensions	1722 x 1134 x 30 mm (1.95 m ²)
Weight	22.0 kg
Glass front/rear	2mm, High transparency, AR coated
Number of cells	108 pcs (6x18)
Cell layout	Mono-crystalline, Half Cut N-Type 16BB/10 BB (182 mm)
Frame	Silver Color, Anodized aluminum alloy
Junction box	IP68 Rated, 3 bypass diodes
Connector type	Staubli MC4-Evo 2 / MC4 (Original)
Cable	4 mm ² , 300 mm

TEMPERATURE PARAMETERS

Temperature Coefficient of Pmax	-0.30 % / °C
Temperature Coefficient of Voc	-0.25 % / °C
Temperature Coefficient of Isc	+0.046 % / °C
Operating Temperature	-40°C to +85°C
Normal Operating Cell Temperature (NOCT)	44±2°C

MAXIMUM RATINGS

Max. System Voltage	1500V DC -(H)
Max. Series Fuse Rating	20 A
Uplift load (wind)	2400 Pa*
Downforce load (snow)	5400 Pa*

*For more information please refer to Instruction Manual

PACKAGING INFORMATION

One pallet quantity	36 pcs
40 ft HC/HQ container	936 pcs

MODULE TYPE	108HCND/10		410 Wp		415 Wp		420 Wp		425 Wp		430 Wp	
	STC	NMOT	STC	NMOT	STC	NMOT	STC	NMOT	STC	NMOT	STC	NMOT
ELECTRICAL CHARACTERISTICS												
Maximum power (Pmax / Wp)	410	308	415	312	420	316	425	320	430	323		
Open circuit voltage (Voc / V)	37.73	35.84	37.92	36.02	38.11	36.20	38.30	36.38	38.49	36.56		
Short circuit current (Isc / A)	13.91	11.23	13.99	11.29	14.07	11.36	14.15	11.42	14.23	11.49		
Maximum power voltage (Vmp / V)	31.13	29.06	31.32	29.21	31.51	29.34	31.70	29.50	31.88	29.63		
Maximum power current (Imp / A)	13.17	10.61	13.25	10.68	13.33	10.76	13.41	10.83	13.49	10.91		
Module efficiency at STC (ηm / %)	21.00		21.25		21.51		21.76		22.02			
Power tolerance (Pmax)	(0,+5) Wp											

STC: Irradiance of 1000 W/m² with spectrum AM 1.5 and a module temperature of 25°C

NMOT: Irradiance 800 W/m², ambient temperature 20°C and wind speed 1 m/s

CERTIFICATES

IEC62716 (Ammonia)
IEC60068-2-68 (Sand)
IEC61215 / 61730 / 61701



P-V Curve at Different Irradiation (430 W)
Cell Temperature 25°C

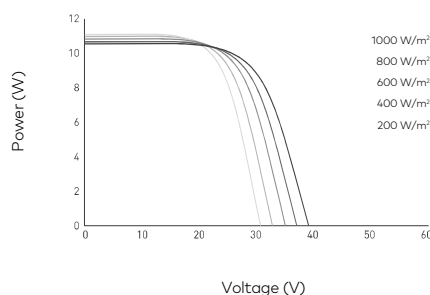

I-V Curve (430 W)
Cell Temperature 25°C

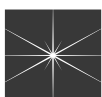
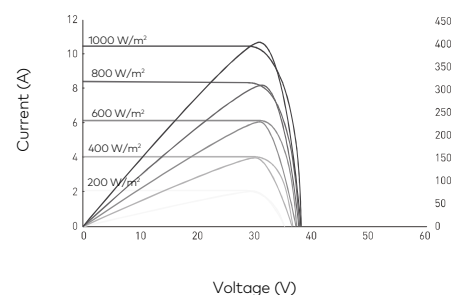

ASTORIOS Holding Inc.
16192 Coastal Highway, Lewes,
Delaware 19958, USA
info@astorios.com