

Aegis T-type Module Specification

Monocrystalline 6X24 Bifacial Solar Modules

385-410Wp



Electrical Data

Model			TS72-6MH-385 H2			TS72-6MH-390 H2			TS72-6MH-395 H2			TS72-6MH-400 H2			TS72-6MH-405 H2			TS72-6MH-410 H2		
			Front	Bifacial Gain		Front	Bifacial Gain		Front	Bifacial Gain		Front	Bifacial Gain		Front	Bifacial Gain		Front	Bifacial Gain	
				5%	10%		5%	10%		5%	10%		5%	10%		5%	10%		5%	10%
Max. power at STC	P _{max}	W	385	404	424	390	410	429	395	415	435	400	420	440	405	425	446	410	431	451
Max. power voltage	V _{pmax}	V	39.71	39.71	39.71	39.85	39.85	39.85	39.99	39.99	39.99	40.13	40.13	40.25	40.25	40.25	40.36	40.36	40.36	
Max. power current	I _{pmax}	A	9.71	10.20	10.68	9.80	10.29	10.78	9.90	10.40	10.89	9.98	10.48	10.98	10.08	10.58	11.09	10.16	10.67	11.18
Open circuit voltage	V _{oc}	V	47.97	47.97	47.97	48.09	48.09	48.09	48.17	48.17	48.17	48.29	48.29	48.29	48.37	48.37	48.37	48.49	48.49	48.49
Short circuit current	I _{sc}	A	10.38	10.90	11.42	10.46	10.98	11.51	10.51	11.04	11.56	10.60	11.13	11.66	10.67	11.20	11.74	10.75	11.29	11.83
Module Conversion Eff.		%	18.95%	19.89%	20.84%	19.19%	20.15%	21.11%	19.44%	20.41%	21.38%	19.68%	20.67%	21.65%	19.93%	20.93%	21.92%	20.18%	21.19%	22.19%

* Under Standard Test Condition (1,000W/m², 25°C, AM 1.5): Power Tolerance ±3%
 * Module Conversion Eff. (%) = [Max power at STC(w) / ((Solar Module Area(m²) x 1000 (w/m²))] x 100%

General Data

Cell type	6" Monocrystalline
Cell per module	Mono-crystalline silicon solar cell (144pcs)
Front	Low-iron tempered glass
Encapsulant Film	Low water vapor transmission rate (WVTR) material
Rear	Tedlar® PVF grid transparent backsheet
Frame	6063T5 Anodized aluminum (silver/black)
Junction Box	IP68
Connector	EVO-2 / EVO-2 Compatible
Cable	1200mm / 4mm ²



Operation Conditions

Max. system voltage	1500V
Module fire resistance class	Class C
Protection Class (IEC 61140)	Class II
Series fuse rating	20 A
Number of bypass diodes	3
Temperature range	-40 to +85°C
Max. mechanical load	5400 pa

Temperature Coefficient

Nominal Operating Cell Temperature	NOCT	°C	44±2
TC I _{sc}	α	%/°C	0.048
TC V _{oc}	β	%/°C	-0.29
TC P _{max}	γ	%/°C	-0.36

Module Dimensions and Weight

Dimension	2028 x 1002 x 40mm
Weight	23 Kgs

IV Curve

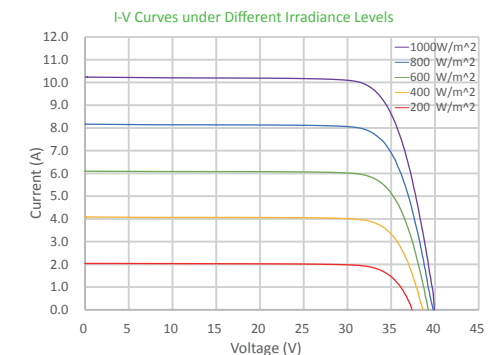

Certifications

- IEC 61215:2016、IEC 61730-1:2016 & IEC 61730-2:2016
- ISO 9001:2015 Quality management system
- ISO 14001:2015 Environmental management system
- ISO 45001:2018 Occupational health and safety management system



Warranty

- 12-year materials and workmanship warranty
- 25-year linear power warranty

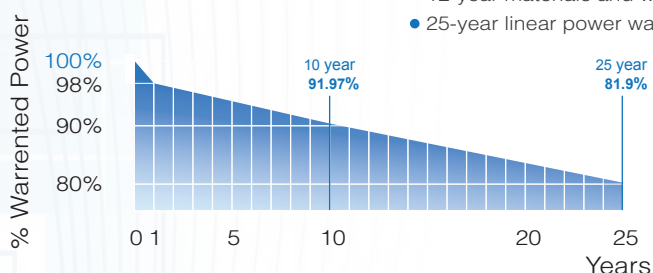

Engineering Drawing (mm)

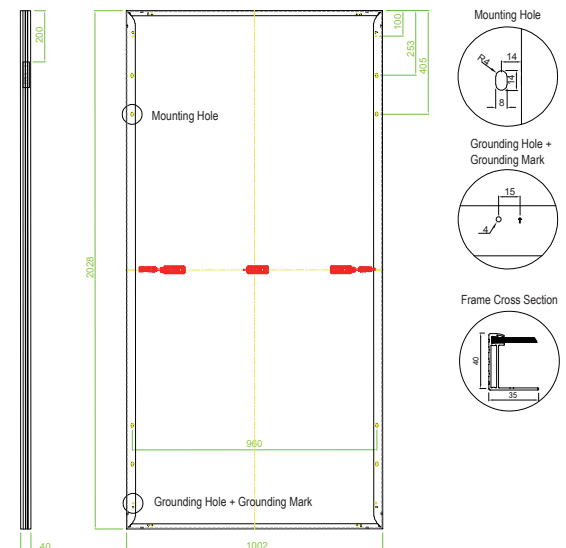

Made in Taiwan

* The information in this document is subject to change without notice * TSEC reserves the rights of final interpretation and revision of datasheet. Version: March 2022.

TSEC Corporation

Taipei Headquarters | 8F., No.225, Sec3, Beixin Rd., Xindian Dist., New Taipei City 23143, Taiwan, R.O.C

T +886-2-2912-2199 F +886-2-2917-5399 M taiwan.sales@tsecpv.com(Sales Contact) epc@tsecpv.com(EPC Construction Service)

Aegis T⁺-type Module Specification

Monocrystalline 6X24 Bifacial Solar Modules for Salt Field Type

385-410Wp



Electrical Data

Model			TS72-6MH-385 H2			TS72-6MH-390 H2			TS72-6MH-395 H2			TS72-6MH-400 H2			TS72-6MH-405 H2			TS72-6MH-410 H2		
			Front	Bifacial Gain		Front	Bifacial Gain		Front	Bifacial Gain		Front	Bifacial Gain		Front	Bifacial Gain		Front	Bifacial Gain	
				5%	10%		5%	10%		5%	10%		5%	10%		5%	10%		5%	10%
Max. power at STC	P _{max}	W	385	404	424	390	410	429	395	415	435	400	420	440	405	425	446	410	431	451
Max. power voltage	V _{pmax}	V	39.71	39.71	39.71	39.85	39.85	39.85	39.99	39.99	39.99	40.13	40.13	40.13	40.25	40.25	40.25	40.36	40.36	40.36
Max. power current	I _{pmax}	A	9.71	10.20	10.68	9.80	10.29	10.78	9.90	10.40	10.89	9.98	10.48	10.98	10.08	10.58	11.09	10.16	10.67	11.18
Open circuit voltage	V _{oc}	V	47.97	47.97	47.97	48.09	48.09	48.09	48.17	48.17	48.17	48.29	48.29	48.29	48.37	48.37	48.37	48.49	48.49	48.49
Short circuit current	I _{sc}	A	10.38	10.90	11.42	10.46	10.98	11.51	10.51	11.04	11.56	10.60	11.13	11.66	10.67	11.20	11.74	10.75	11.29	11.83
Module Conversion Eff.		%	18.95%	19.89%	20.84%	19.19%	20.15%	21.11%	19.44%	20.41%	21.38%	19.68%	20.67%	21.65%	19.93%	20.93%	21.92%	20.18%	21.19%	22.19%

* Under Standard Test Condition (1,000W/m², 25°C, AM 1.5): Power Tolerance ±3%
 * Module Conversion Eff. (%) = [Max power at STC(w) / ((Solar Module Area(m²)) x 1000 (w/m²))] x 100%

General Data

Cell type	6" Monocrystalline
Cell per module	Mono-crystalline silicon solar cell (144pcs)
Front	Low-iron tempered glass
Encapsulant Film	Low water vapor transmission rate (WVTR) material
Rear	Tedlar® PVF grid transparent backsheets
Frame	Anti-Salt Mist 6063T5 aluminum (silver / black)
Junction Box	IP68
Connector	EVO-2 / EVO-2 Compatible
Cable	1200mm / 4mm ²



Operation Conditions

Max. system voltage	1500V
Module fire resistance class	Class C
Protection Class (IEC 61140)	Class II
Series fuse rating	20 A
Number of bypass diodes	3
Temperature range	-40 to +85°C
Max. mechanical load	5400 pa

Temperature Coefficient

Nominal Operating Cell Temperature	NOCT	°C	44±2
TC I _{sc}	α	%/°C	0.048
TC V _{oc}	β	%/°C	-0.29
TC P _{max}	γ	%/°C	-0.36

Module Dimensions and Weight

Dimension	2028 x 1002 x 40mm
Weight	23 Kgs

IV Curve

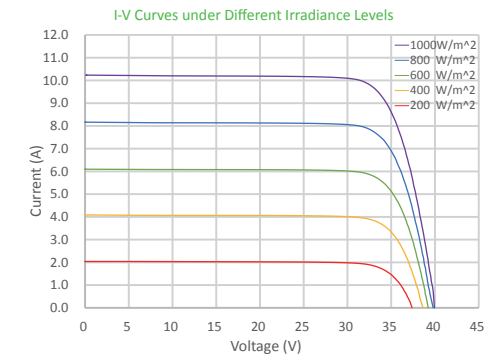

Certifications

- IEC 61215:2016、IEC 61730-1:2016 & IEC 61730-2:2016
- ISO 9001:2015 Quality management system
- ISO 14001:2015 Environmental management system
- ISO 45001:2018 Occupational health and safety management system



Warranty

- 12-year materials and workmanship warranty
- 25-year linear power warranty

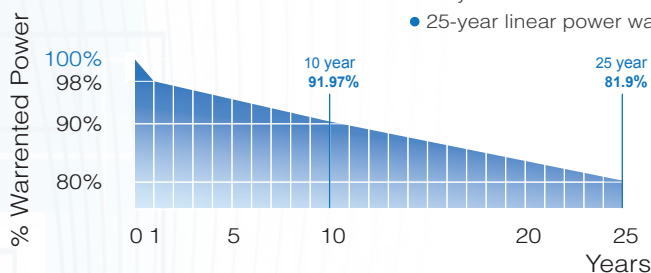

Engineering Drawing (mm)

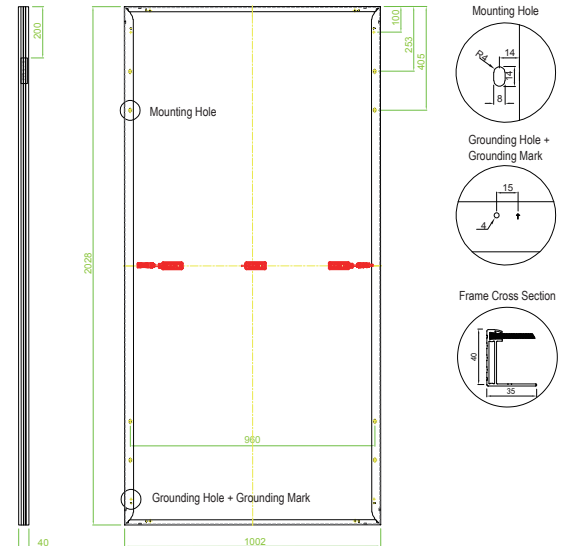

Made in Taiwan

* The information in this document is subject to change without notice * TSEC reserves the rights of final interpretation and revision of datasheet. Version: March 2022.

TSEC Corporation

Taipei Headquarters | 8F., No.225, Sec3, Beixin Rd., Xindian Dist., New Taipei City 23143, Taiwan, R.O.C

T +886-2-2912-2199 F +886-2-2917-5399 Mtaiwan.sales@tsecpv.com(Sales Contact) epc@tsecpv.com(EPC Construction Service)