



Power Lite Plus  
(PLPA-L1-5K1) Product Specification

Ver 1.5



# 产 品 规 格 书

## PRODUCT SPECIFICATION

产品名称： 储能电池系统

APPELLATION: Power Lite Plus

产品型号： PLPA-L1-5K1

MODEL:

客户名称：

CUSTOMER:

版 本： V1.5

VERSION:

客户承认

CUSTOMER APPROVED

签名：

Signature:

职务：

Duty:

日期：

Date:

Note:

Any new content will be added to the back of this document in the form of an attachment.



Revision History:

Date	Revision	Description	Owner
2022-10-11	V1.0	Initial Release	XQ Liu
2022-11-28	V1.1	Update Electrical parameters	Mark Tang
2022-12-14	V1.2	Add more installation methods	XQ Liu
2023-03-15	V1.3	New cable over current capability	XQ Liu
2023-04-07	V1.4	Updated the RJ45 cable definition	XQ Liu
2023-05-16	V1.5	Parameter error, update parameter	XQ Liu



## Table of Contents

<b>1. System</b> .....	<b>5</b>
1.1 Applicable Scope .....	5
1.2 Standard Environmental Test Conditions .....	5
1.3 System Appearance/Component .....	5
1.4 Detailed Specifications .....	5
1.5 Electrical Schematic .....	7
1.6 Battery System Panel Connector .....	7
<b>2. Scope of Supply</b> .....	<b>9</b>
<b>3. Label</b> .....	<b>11</b>
3.1 Product Label .....	11
3.2 SN Label .....	11
<b>4. Package, transportation and storage</b> .....	<b>12</b>
4.1 Package .....	12
4.2 Transportation .....	13
4.3 Storage .....	14
<b>5. Appendix Handling Precautions and Guidelines for Product</b> .....	<b>16</b>
<b>6. Disclaimer</b> .....	<b>18</b>
6.1 Customer Responsibility .....	18
<b>7. Recycling disposal</b> .....	<b>20</b>

## 1. System

### 1.1 Applicable Scope

The purpose of this product specification (“Document”) is to specify the specifications of the rechargeable lithium battery system(System or Product) to be supplied by UZENERGY to Customer based on customer requirements.. For the avoidance of doubt, the specifications specified herein only apply to UZ product.

### 1.2 Standard Environmental Test Conditions

Unless otherwise specified, all tests stated in this Document are conducted at below conditions:

1. Temperature:  $25 \pm 3$  °C (Temperature Condition)
2. Humidity: <95% RH (Non-Condensing)

Throughout this document, numeric criteria annotated by “\*” means such criteria are only applicable to fresh unused Product within 30 days from UZENERGY manufacturing date. Products either have been used or stored for a period longer than 30 days by Customer and/or its customer may exhibit an inferior numeric parameter than such criteria.Customer agrees that such occurrence does not constitute non conformance of specification

### 1.3 System Appearance/Component

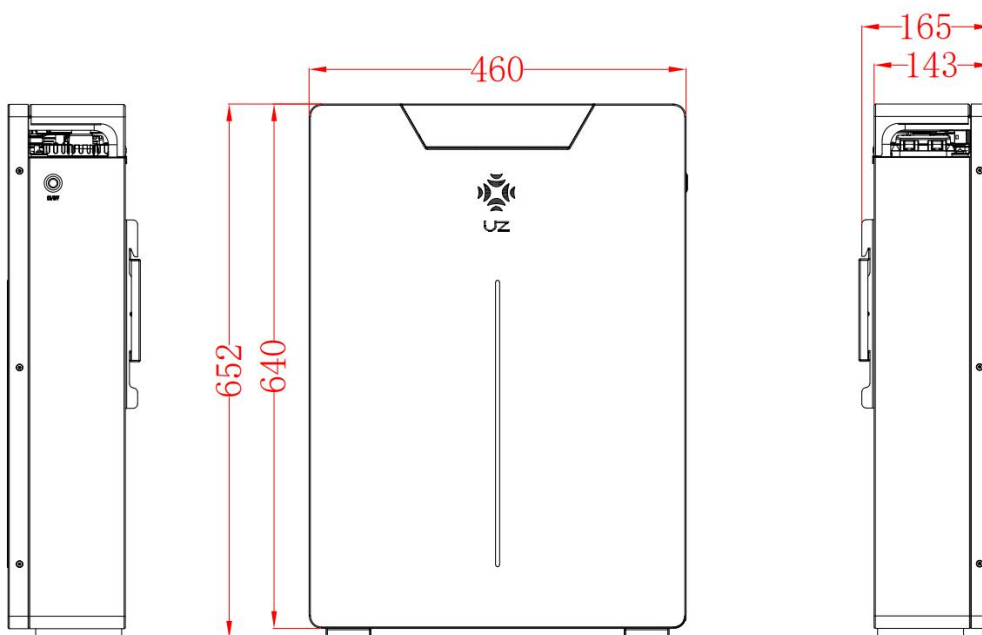

Fig 1.1.1

### 1.4 Detailed Specifications

Key Item	Specification	Remark
Rated Capacity	100 Ah	
Rated Voltage	51.2 V	
Rated Current	0.6C, 60 A	
Working Voltage Range	44.8-58.4 V	



Rated Energy	5.12 kWh	
Max. Parallel Quantity	Max. 32 Sets In Parallel , 163.84 kWh	
Rated Charging Current	0.6C , 60 A	
Max. Charging Continuous Current	0.6C , 60 A	
Rated Discharge Current	0.6C , 60 A	
Max. Discharge Continuous Current	1C, 100 A	>70% SOC
Battery Max. Charge/Discharge Power	3.07 kW/5.12 kW	
Peak Discharge Current / Power	105 A/5.37 kW, 1min	
Standard Charging Method	0.5C CC to 57.6 V; CV at 57.6 V Till Current Is 0.05C	
Available SOC Range	0% ~ 100%	90% DOD is Recommended.
SOC Transportation Range	50%	
Dimensions [W*D*H]	Width: 460 (±5) mm/18.11 in, Depth: 165 (±5) mm/6.5 in, Height: 652 (±5) mm/25.67 in,	
Weight	~50 kg	
Operating Temperature <sup>1</sup>	Charging Temperature: -5°C~55°C Discharge Temperature: -15°C~55°C	
Storage Temperature <sup>2</sup>	-15°C ~ 55 °C	
Working Humidity	<95% RH (non-condensing)	
Altitude <sup>3</sup>	≤2000 m	
Communication	CAN, RS485, Dry Contact, WiFi	WiFi Stick Option
Certificate	TUV, IEC 62619, IEC62040, IEC61000, UN38.3	
Designed Cycle Life	6000	0.5C/80%DOD/80%S OH/1 cycle per day
Designed Calendar Life	15 Years	Working Condition 0.5 C @ 25 deg C, 80% DoD, 1 cycle per day
IP Rating	IP65	
Cooling	Natural Cooling	
Heating Power	Max. 230.4 W	
Environment Protection Standard	RoHS, REACH	

1. Recommended operating temperature: 10~30 °C.
2. Recommended Storage temperature: 10~30 °C.
3. Recommended working height is less than 2000 m, and the max. working height is 3000 m.

### 1.5 Electrical Schematic

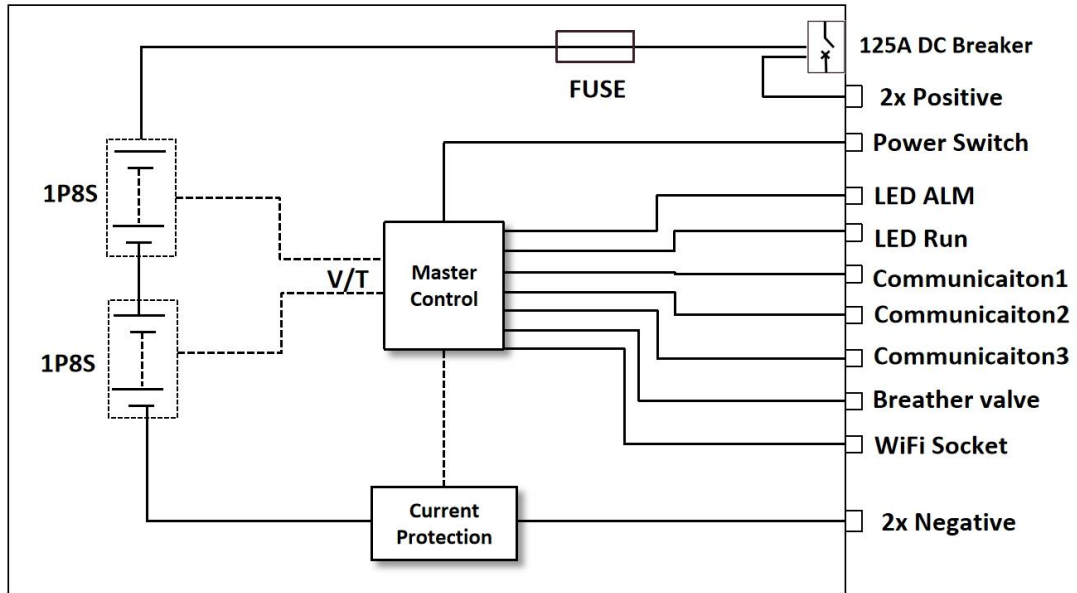

Fig 1.5.1

### 1.6 Battery System Panel Connector

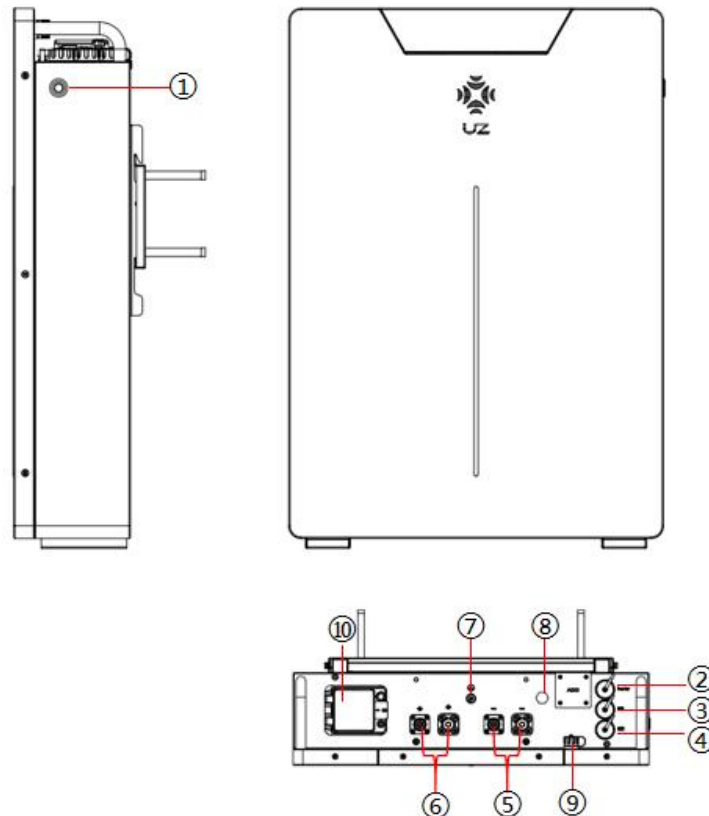



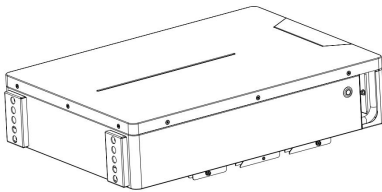
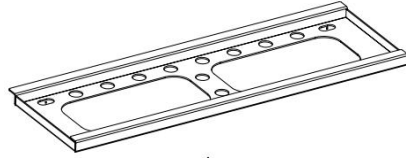
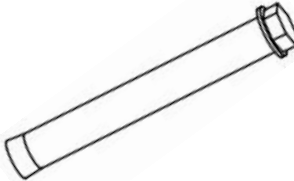
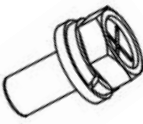
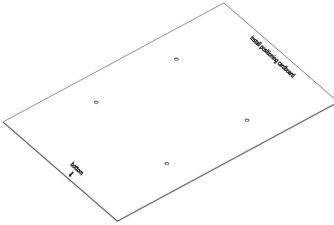



Fig 1.6.1

Item	Name	Model	Remarks
1	Power Switch		Red light:ALM Blue light:RUN
2	Communication port 	RJ45	<b>Battery To INVERTER</b> Pin 1: NA Pin 2: PCS-485-A Pin 3: PCS-485-B Pin 4: PCS-CAN-H Pin 5: PCS-CAN-L Pin 6: GND Pin 7: NA Pin 8: NA
3	Communication port 	RJ45	<b>Internal Connection (LINK IN)</b> Pin 1: NC Pin 2: BMS-485-A Pin 3: BMS-485-B Pin 4: DI+ Pin 5: DI- Pin 6: NC Pin 7: BMS-CAN-H Pin 8: BMS-CAN-L
4	Communication port 	RJ45	<b>Internal Connection (LINK OUT)</b> Pin 1: NC Pin 2: BMS-485-A Pin 3: BMS-485-B Pin 4: DO+ Pin 5: DO- Pin 6: NC Pin 7: BMS-CAN-H Pin 8: BMS-CAN-L
5	Port Negative x2	PSR6XABM5A	Black cable 25 mm <sup>2</sup> , cable plug model: PSRP6XA25A
6	Port Positive x2	PSR6XCBM5A	Red cable 25 mm <sup>2</sup> , cable plug model: PSRP6XC25A
7	GND	M6	Yellow-Green, 10 AWG
8	Breather Valve		
9	WIFI Socket	Magpie WiFi Stick V190603-R	Function (Option)
10	125 A DC Breaker		



## 2. Scope of Supply

Key Item	Number	Describe	Specification
Battery pack	1		51.2 V100 Ah
Back plate support	1		
Expansion screw	4		M8*80 mm
Screw	2		M5*14 mm
Mounting positioning board	1		
RJ45 Waterproof wiring terminal	3		
Positive DC cable	1	Red cable, 25 mm <sup>2</sup> , cable length 1.5m; one side hot plug:Orange__ PSRP6XC25A, one side SC35-8 terminal;Continuous flow capacity:100 A	



Negative DC cable	1	Black cable, 25 mm <sup>2</sup> , cable length 1.5 m; Single-sided hot swap: black _PSRP6XA25A, single-sided SC35-8 terminal;Continuous flow capacity:100 A	
Communication cable	1	Standard communication cable,Length:1.5 m__Black__CAT 5 (8P8C) , Both injection molding metal crystal head; Battery 4H5L;	
Ground wire	1	Yellow green wire UL3512 10WAG_Length:1 m,double M6 OT Terminal	

### 3. Label

#### 3.1 Product Label

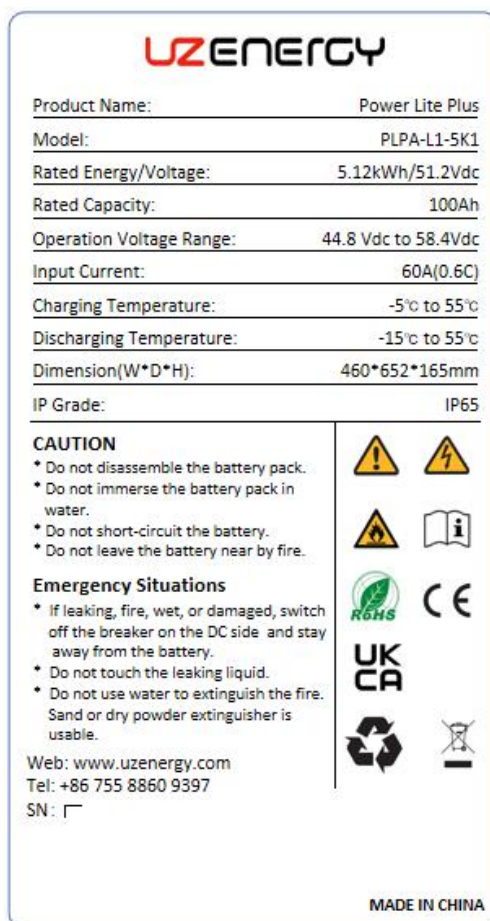

Requirement: Dimension: 80x150mm;

Scale 1:1 according to drawing scale;

Material: PET;

Single-sided adhesive: 3M 467MP.

#### 3.2 SN Label



Requirement: Dimension: 50x15mm,code height: 10mm

Scale 1:1 according to drawing scale;

Material: PET;

Single-sided adhesive: 3M 467MP.

## 4. Package, transportation and storage

Customer shall ensure that the Products are handled, operated, used and maintained by professionals qualified for such Products and that such professionals shall handle the Products in accordance with the Product User Manual (“User Manual”) provided by UZENERGY as well as in accordance with local laws and regulations. Customer shall alert its customers, contract manufacturers, agents, distributors, service providers and end users of the risks of the products given and are provided with adequate instructions as per such User Manual; Customer shall also ensure that Customer’s obligations as specified in the Document as well as the User Manual are, through a printed label on host device, or through Customer’s user manual, or a help file or Customer’s Internet website, contractually imposed on Customer’s own customers and distributors, and by them further down to the end users so that the entire chain is committed to the above obligations and so that the products are properly handled, operated, transported, used and maintained.

### 4.1 Package

#### 4.1.1 Battery packing

Size of carton : 708 mm (L)\*543 mm (W)\*237 mm (H).The packaging process is shown in the following figure.

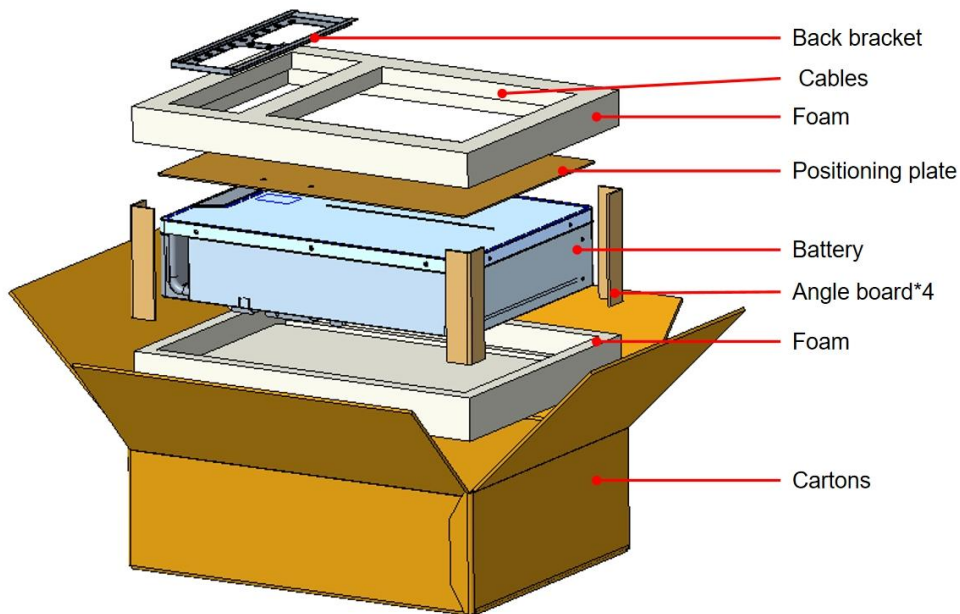

Fig4.11

#### 4.1.2 Stacking method

One pallet can be stacked only four layers with a height of 1060mm; Paper box should be equipped with corner protection and wrapped with films.

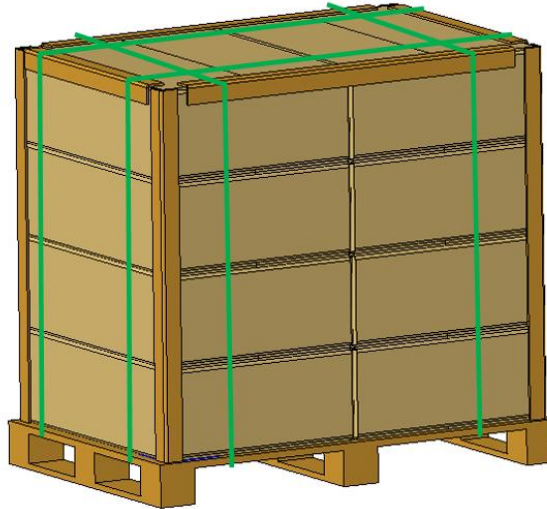

Fig4.1.2

## 4.2 Transportation

Modules has cleared UN38.3 (Section 38.3 of the seventh Revised Edition of the Recommendations on the Transport of Dangerous Goods: Manual of Tests and Criteria) and SN/T 0370.2-2009 (Part 2: Performance Test of the Rules for the Inspection of packaging for Exporting Dangerous Goods). The module is classified as class 9 dangerous goods, and shall be transported in accordance with the following:

1. Use van-type vehicle including container and metallic van-type vehicle. Platform vehicle and convertible are prohibited

2. In order to protect modules from moving, falling or crashing, bandages and bubble bags shall be adopted during transportation. Specifically, bandages apply to both long and short distance transports, and at least the last 1-2 rows at vehicle rear shall be bandaged. Short distance transport does not need bubble bags. But both bubble bags and bandages (at least the vehicle rear) should be used for long distance transport. If there isn't enough space for bubble bags, bandage application inside the whole car is an option.

3. Vehicle in the middle of unloading should berth near dock. Vehicles waiting to be unloaded should keep a safe distance of 6 m from warehouse. The vehicle prohibits debris stacking and should stay away from other vehicles.

4. Prohibit mixing up with explosive, inflammable or toxic objects.

5. Prohibit piling up with other objects.

6. Maintain original packaging and keep labels complete and recognizable.

7. Prevent from direct exposure to sunlight, rain, condensation and mechanical damage.

8. Do not stack modules more than five layers and do not stack BMS Boxes more than 4 layers.

9. Maintain temperature between -10°C and 45°C, and keep humidity within 5%-95%RH during the storage.

10. Carriers should be equipped with extinguishers designed specifically for lithium battery, which



are used together with fire protection water and sand

11. A damaged box or rattles during transport may indicate rough handling. Describe the damages on the delivery receipt before signing. If an obvious damage such as package hole or serious impact is found, please contact UZENERGY

### 4.3 Storage

#### 4.3.1 Warehouse Management

1. It is not recommended to store modules in 7-meter-height warehouse. In case of the warehouse, Modules should be placed not higher than two meters from floor.

2. Modules with safety deficiency and normal modules should be stored in separated areas with wall in-between or in different fire protection zones.

3. Prevent electrical fire sources. Electrical tube, switch box and socket should be undamaged. 0.5 meters from floor standing air conditioner and dehumidifier should be free from inflammable materials. Use cold light source in warehouse. If spotlight is used, at least one meter therefrom should be free from other inflammable materials.

4. Warehouse should be labeled with smoking ban and confirmed without cigarette butts. Smoking points should be reasonably designed with a fire-retardant wall separating warehouse. Wind at exit cannot blow cigarette butt to the ground near warehouse.

5. Rodent prevention measures should be taken in the warehouse, such as blocking holes, putting floor baffles. The clearance of door slots should be less than 10mm.

6. Warehouse canopy must use fire retardant materials . Prohibit inflammable materials like plastic or canvas.

7. Warehouse should be equipped with fire detector, watch-keeper, and surveillance video cameras and videos should be kept for at least one month.

8. It is recommended that batteries not be stored for a long period. They should be used soon after being deployed onsite. The batteries should be handled according to the following requirements.

Required Storage Temperature	Actual Storage Temperature	Recharge Interval	Remarks
-10°C < T ≤ 55°C	T ≤ -10°C	Not allowed	Not reaching the time for recharge: Use the battery as soon as possible. Reaching the time for recharge: Recharge the batteries.
	-10°C < T ≤ +25°C	12 months	
	25°C < T ≤ 35°C	9 months	
	35°C < T ≤ 55°C	6 months	
	55°C < T	Not allowed	

8.1. Dispose of deformed, damaged, or leaking batteries directly irrespective of how long they have been stored.

8.2. The storage duration starts from the latest charge time labeled on the battery package. If a battery is qualified after recharge, update the latest charge time and the next recharge time (next recharge time = latest charge time +recharge interval) on the label.



8.3. The maximum power storage period of a lithium battery is three years. A lithium battery can be recharged at most for three times within the three years. For example, it can be recharged every 8 months or every 12 months. It is recommended that batteries be scrapped if the maximum allowable storage period and recharging times are exceeded.

8.4. If a lithium battery is stored for a long time, capacity loss may occur. After a lithium battery is stored for 12 months in the recommended storage temperature, the irreversible capacity loss rate is 3%–10%. If customers perform the discharge test according to the specifications, they may fail to pass the test if the storage capacity of the battery is not 100% of the rated capacity.

9. Module performance is susceptible to chemical corrosion, strong acid, strong base, electrochemistry corrosion, salt spray and radiation.

#### **4.3.2 Fire extinguish device**

1. Battery sites must be equipped with multiple varieties of battery fire extinguishers, including fire sand, blanket and powder extinguisher.

2. It is recommended to deploy a micro fire station with firefighter uniforms, helmets, fire protection masks, safety gloves, and at least one set of first aid kit including medical devices and drugs.

#### **4.3.3 Smoke discharge**

1. Equip the room with independent fans that run 24 hours/7 days and have failure alert function. Fans should coordinate with smoke detectors or gas concentration detectors.

2. The ventilation capability should not be less than 12 times per hour and wind speed should exceed 0.5 meter per second.

3. Fan portfolio includes axial flow fan on wall (effective distance less than 5 meters), fan with fixed air hose, and mobile fan with flexible aluminum foil. The combination of wall fan and mobile fan is recommended.

#### **4.3.4 Fire retardant buildings**

Warehouse and plant should use level two fire retardant buildings, like rock wool colour steel plate, plasterboard and iron rain-shed. Inflammable materials like foam and plastics are prohibited.

#### **4.3.5 Separate storage**

1. Do NOT store lithium batteries with inflammable or toxic objects.

2. Design various fire protection zones. Store normal modules and modules with safety deficiencies separately.

#### **4.3.6 Recharge**

Keep the shipment module SOC less than 50% and charge the module if it has been stored for more than 12 months.

Set CV to 51V and CC to 10A and charge the module for 2H until module terminal blocks are measured ranging from 46.2V to 51V.



## 5. Appendix Handling Precautions and Guidelines for Product

These Handling Precautions and Guidelines for Rechargeable Battery System (“Handling Precautions and Guidelines”) shall only apply to the modules manufactured by UZENERGY. Customer shall strictly follow these Handling Precautions and Guidelines, and shall alert its customers, contract manufacturers, agents, distributors, service providers and end users of the risks of the modules and shall ensure that Customer’s obligations as specified in the Document as well as the Handling Precautions and Guidelines are, through a printed label on host device, or through Customer’s user manual, or a help file or Customer’s Internet website, contractually imposed on Customer’s own customers and distributors, and by them further down to the end users so that the entire chain is committed to the above obligations and so that the products are properly handled, operated, transported, used and maintained.

### **Statement(1) :**

Customer is requested to contact UZENERGY in advance, if and when the customer needs other applications or operating conditions than those described in this Document. Additional experimentation may be required to verify performance and safety under such conditions

### **Statement (2) :**

UZENERGY will take no responsibility for any accident or liabilities in the event the Product is used for applications or under conditions other than those described in this Document.

- Use Product under specified charge/discharge conditions.
- Do not immerse in water.
- Do not heat.
- Do not attempt to crush, drop or penetrate the module.
- Do not attempt to have any modification/.
- Leave Product in cool places.
- Stop using Product with any colour change or mechanical damage detected during assembling, charging, normal operation and storage .
- In case of leakage or smells, track to thermal source, remove the thermal source and clean with water.
- Do not place or leave the module and equipment in the reach of children so that they are not able to swallow or mistreat the product. In case of ingestion, consult with a doctor immediately.
- Keep leaked electrolyte away from eyes or skin. In case of leakage contact with eyes or skin, immediately clean with water and seek help from a doctor. Serious damages can be caused due to delayed treatment.
- Do not put the module into a fire. Do not use it or leave it in a place near fire, heaters, or high temperature sources. The heat can melt module insulator and damage safety vent, resulting in overheat, explosion or fire of the module .
- Do not submerge the product in water, or wet the product. If the protective devices are





damaged, abnormal charging current and voltage may cause a chemical reaction within the product, which may result in overheat, explosion and even fire of the module .

- Do not connect positive (+) and negative (-) terminals of the module reversely.
- Do not short circuit. Do not contact the module terminals (+ and -) directly with a wire or any metal (like a metal necklace or a hairpin). Otherwise, the module is short circuited and generates excessive current, which may result in overheat, explosion, or fire of the module .
- Do not throw or drop the module. Strong impact may damage the protective devices and an abnormal chemical reaction might occur during charge, resulting in overheat, explosion, or fire of the module.
- Do not drive a nail in, hit with a hammer, or stamp on the module. Otherwise, the module may be deformed and short circuited, resulting in overheat, explosion, or fire of the module.
- Do not solder the module directly. Heat applied during soldering may damage the insulator of the safety vent and mechanism, resulting in overheat, explosion, or fire of the module.
- Do not disassemble or alter the module. The module employs a safety mechanism and a protection device in order to avoid any danger. If they are damaged, the module might overheat, explode or catch a fire.
- Do not put the module in a microwave oven or a pressure cooker. Sudden heat may damage the sealing of the module and may cause overheat, explosion, or fire of the module.
- Do not leave the module in a charger or equipment if it generates an odour and/or heat, changes colour and /or shape, leaks electrolyte, or encounters any other abnormality. In such a case, immediately take the module out of the charger or equipment and keep it away from fire. Otherwise, the module might overheat, explode, or catch a fire.
- Stop charging or using the battery after battery reaches its lifetime, otherwise, as the PACK might cause heat generation, explosion, or fire.
- Do not use the module beyond specified conditions. Otherwise, the module might encounter overheat, damage, or performance deterioration .
- Read the instructions regarding the installation and operation so as to avoid damages due to incorrect operations.
- The module may have insufficient power capacity after long storage.
- Knockoff or counterfeit battery.
- Any inconsistency between serial number, model number, and product code.



## 6. Disclaimer

### 6.1 Customer Responsibility

The Customer hereby agrees that it has carefully read and understood any and all terms and conditions, safety precautions and measures set forth in this Document, furthermore, the Customer waives claiming any liability against UZENERGY and agrees to bear full responsibilities of the risks for any accidents, bodily injuries, or property loss that may occur due to non-compliance with any of the above.

Regarding a particular Product with the properties, the Customer is obligated to verify the fitness for a particular purpose of such Product described in this Document under certain application. The parameters provided in this Document may vary in different applications and performance may vary from time to time. All operating parameters, including typical parameters, must be validated for each customer application by the Customer's technical experts .

Customer takes full responsibility to verify all requirements (whether voluntary or mandatory) necessary to enter into a certain market or territory, including but not limited to technical, environmental, safety certification or other requirements. Unless expressly provided herein, UZENERGY shall in no event be liable for any failure of the Product to fit for a certain application or to meet any requirement necessary to enter into a specific market or territory. The parties agree that the certification items and certification institutions are designated or agreed by Customer. UZENERGY will assist the designated certification institutions to conduct testing and issue certificates for the Products by providing all necessary documentations for certification, including specification, product label, application form and samples. The parties further agree that all expenses and liabilities in connection with or arising from the certification shall be borne by Customer, and UZENERGY shall in no event be liable for any costs or expenses in connection with or resulting from any failure to pass the certification or the non-compliance with any voluntary or mandatory certification requirement in any specific territory.

The Product is produced and supplied to the Customer for Business to Business nature, and is not for direct consumer use. Due to safety and technical reasons, the average lifespan for the Product is [13] years from the [manufacturing date], depending on different user habits and conditions ("Average Lifespan"). The term Average Lifespan shall have different meaning from the term Warranty Period. Customer hereby acknowledges the Average Lifespan of the Product and agrees to be responsible to handle after sales service (except for instances where UZENERGY's limited warranty applies) and take liability for claims raised by end users and consumers, and UZENERGY is only responsible in accordance with this Document to the Customer, and not to end users and/or consumers.

Customer agrees to take full responsibility for recycling the Product in accordance with the local laws and regulations in the respective Permitted Territory and shall bear the costs arising therefrom.



Products can only be used and installed within the Permitted Territory as set forth in the cover page of this Document (“Permitted Territory”). The Product warranty is null and void in the event Products are resold, used or installed outside of the Permitted Territory.

Except as expressly set forth in this document, UZENERGY makes no representations or warranties of any kind, express or implied, including, but not limited to, warranties of quality, merchantability, any implied warranties of fitness for a particular use or purpose and non-infringement.

The parties agree that UZENERGY shall have no liability or obligation with respect to any infringement, claim or action which is based upon:

- UZENERGY's incorporation or use of materials, designs, technology or intellectual property designed, designated or instructed by Customer, its affiliates, contract manufacturers, customers, or end users into the Products.
- The combination, assembly, operation, or use of the Products with materials, devices, parts, or software not supplied by UZENERGY.
- Modifications, disassembly, repair, and rework to the Products by Customer or any third party without the prior written consent of UZENERGY.
- UZENERGY's modification of the Products in compliance with the design, specification, requirements, or instructions of Customer.
- The claim or action arising from non-compliance with the requirements for use, storage, delivery, assembly, and disposal of the Products designated by UZENERGY.
- Use of the Products beyond the scope of intended use under this Document; or any defect that may exist before the Product enters the market or any defect that is unable to be detected by the existing technology at the time the Product enters market.

For any product liability related claim raised against UZENERGY, the Customer bears the burden of proof to evidence that :

(1) The Customer and its contractors, agents, customers or end users have followed the requirements of this Document,

(2) There is a product defect

(3) The accident, claim or liability is solely and directly caused by such product defect. UZENERGY is entitled to reject any claim and be released from any liability in the event of Customer's failure to meet the aforesaid burden of proof.

UZENERGY shall have no liability or obligation with respect to any Products which have been subjected to abuse, misuse, improper use, negligence, accident, alternation, repair or rework performed by any unauthorized persons or entities other than UZENERGY.

Neither party shall be liable for any indirect, special, incidental, punitive or consequential damages of any kind (including lost profits), regardless of the form of action, whether in contract, tort (including negligence), strict liability or otherwise, even if informed of the possibility of such damages in advance.

The parties hereby agree that UZENERGY's entire liability, if any, in damages, indemnification or otherwise, shall not exceed the Product price paid by Customer allocable to the specific Product upon which the claim is directly based.

## 7. Recycling disposal

The batteries may only be disposed of in accordance with the disposal regulations for used batteries applicable at the time of disposal. Immediately decommission any damaged batteries and please contact your installer or sales partner first before disposal. Ensure that the battery is not subjected to moisture or direct sunlight. Ensure quick removal by your installer.

- Batteries, including rechargeable batteries, may not be disposed of in household waste. You are legally obligated to return used batteries.
- Used batteries may contain pollutants that can damage the environment or harm your health if they are not stored or disposed of properly
- Batteries also contain important raw materials such as iron, zinc, manganese, copper, cobalt or nickel and can be recycled.

Do not dispose of batteries in household waste!





Shenzhen UZ Energy Limited

Add: Room 313, 3rd floor, Building 2, Meilin Dori Industrial Zone, Beihuan Road,  
Meifeng Community, Meilin Street, Futian District, Shenzhen

Tel: 86-755-88609397

E-mail: [marketing@uzenergy.com](mailto:marketing@uzenergy.com)

<http://www.uzenergy.com>