

GENERAL FEATURE

- Absorbent Glass Mat(AGM) technology for efficient gas recombination of up to 99% and freedom from electrolyte maintenance or water adding.
- Not restricted for air transport-complies with IATA/ICAO Special Provision A67.
- Can be mounted in any orientation.
- Computer designed lead,calcium tin alloy grid for high power density.
- Long service life,float or cyclic applications.
- Maintenance-free operation.
- Low self discharge.



SPECIFICATION

Nominal voltage	12V
Number of cell	6
Length(mm/inch)	350/13.78
Width(mm/inch)	166/6.54
Height(mm/inch)	174/6.85
Total Height(mm/inch)	174/6.85
Approx.Weight(kg/lbs)	17.85/39.35

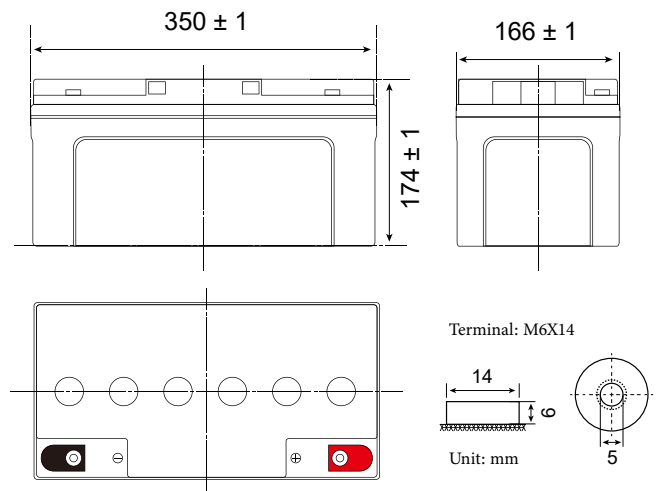

MATERIAL

Component	Positive plate	Negative plate	Container	Cover	Safety valve	Terminal	Separator	Electrolyte
Raw material	Lead dioxide	Lead	ABS	ABS	Rubber	Copper	Fiberglass	Sulfuric acid

CONFIGURATION

Capacity 77°F(25°C)	20 hours rate (3.2A 10.8V)	64Ah
	10 hours rate (6.0A 10.8V)	60Ah
	5 hours rate (10.4A 10.5V)	52Ah
	1 hour rate (37.0A 9.6V)	37Ah
Internal Resistance	Full charged battery 77°F(25°C):8m Ω	
Capacity affected by Temperature (10 hour rate)	104°F(40°C)	102%
	77°F(25°C)	100%
	32°F(10°C)	85%
	5°F(-15°C)	65%
Self-Discharge 68°F(20°C)	Capacity after 3 month storage	90%
	Capacity after 6 month storage	80%
	Capacity after 12 month storage	60%
Max discharge current 77°F(25°C):600A(5S)		
Charge (Constant Voltage)	Float:13.6 to 13.8V/77°F(25°C)	
	Cycle:14.5 to 14.9V/77°F(25°C) Max Current:15A	

PERFORMANCE REPORT

Charge characteristic curve

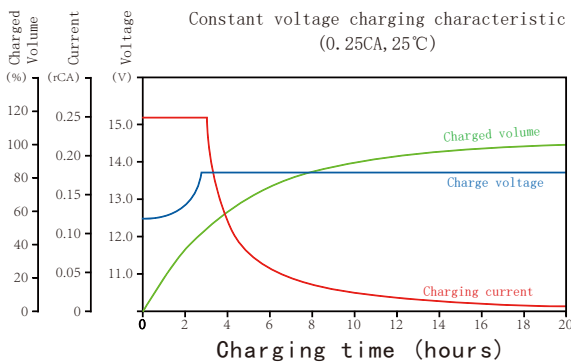

Discharge characteristic (25°C)

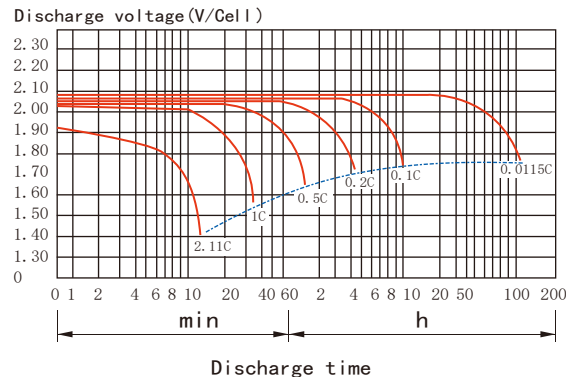

Temperature effects on float life

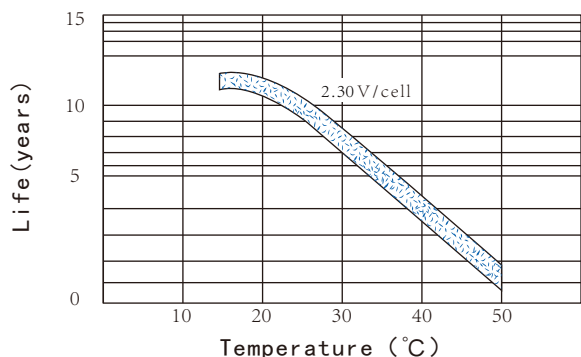

Cycle service life in relation to depth of discharge

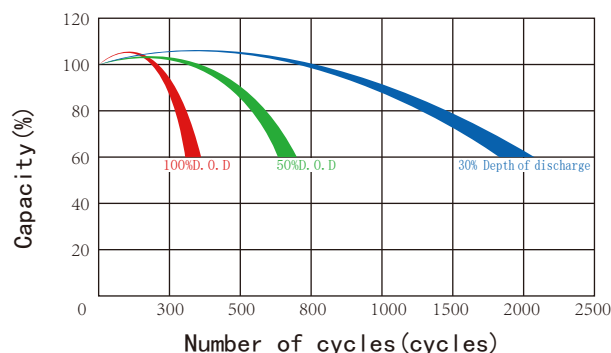

Relationship between charging voltage and temperature

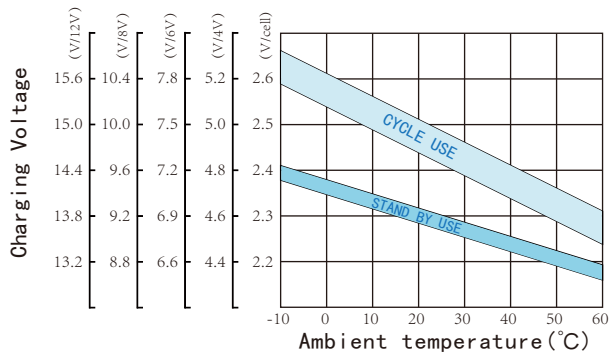

Self-discharge characteristic

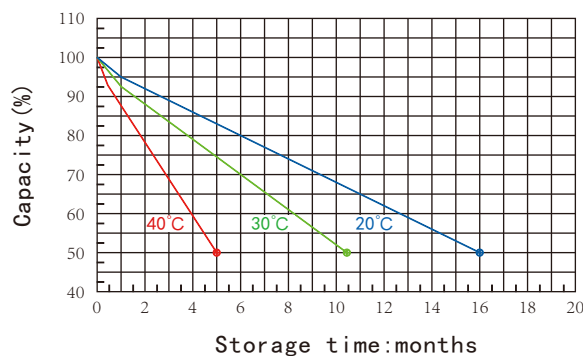

Life characteristics of standby use

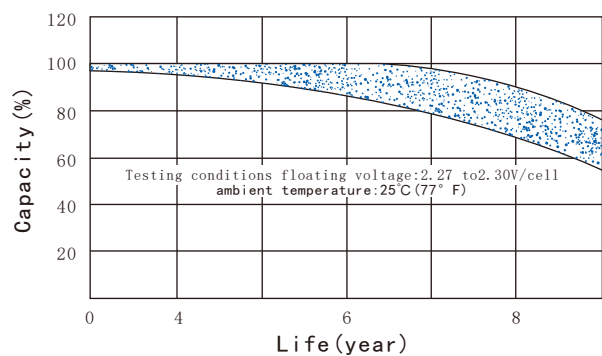

Temperature effects on capacity

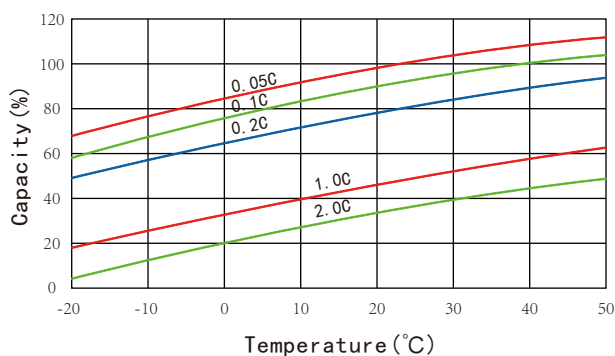

GENERAL FEATURE

- Micro millimeter SiO₂ and H₂SO₄ technology for efficient gas recombination of up to 99% and freedom from electrolyte maintenance or water adding.
- Not restricted for air transport-complies with IATA/ICAO Special Provision A67.
- Can be mounted in any orientation.
- Computer designed lead,calcium tin alloy grid for high power density.
- Long service life,float or cyclic applications.
- Maintenance-free operation.
- Low self discharge.



SPECIFICATION

Nominal voltage 12V
 Number of cell 6
 Length(mm/inch) 407/16.02
 Width(mm/inch) 174/6.85
 Height(mm/inch) 209/8.23
 Total Height(mm/inch) 233/9.17
 Approx.Weight(kg/lbs) 29/63.93

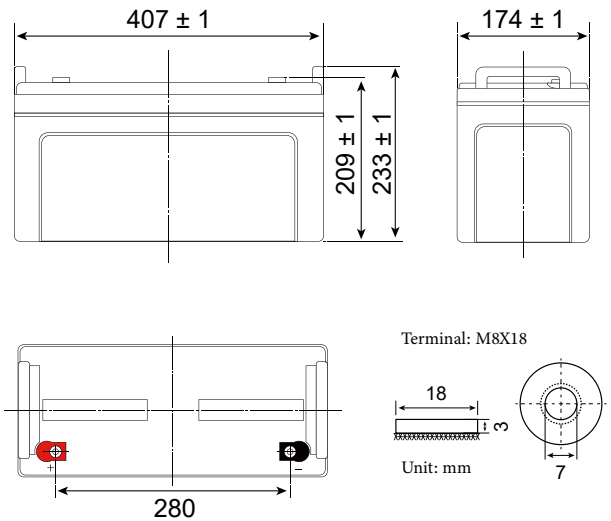

MATERIAL

Component	Positive plate	Negative plate	Container	Cover	Safety valve	Terminal	Separator	Electrolyte
Raw material	Lead dioxide	Lead	ABS	ABS	Rubber	Copper	Fiberglass	Colloidal Silicon

CONFIGURATION

Capacity 77°F(25°C)	20 hours rate (5.2A 10.8V)	104Ah
	10 hours rate (10A 10.8V)	100Ah
	5 hours rate (17.4A 10.5V)	87Ah
	1 hour rate (63.5A 9.6V)	63.5Ah
Internal Resistance	Full charged battery 77°F(25°C):6mΩ	
Capacity affected by Temperature (10 hour rate)	104°F(40°C)	102%
	77°F(25°C)	100%
	32°F(10°C)	85%
	5°F(-15°C)	65%
Self-Discharge 68°F(20°C)	Capacity after 3 month storage	90%
	Capacity after 6 month storage	80%
	Capacity after 12 month storage	60%
Max discharge current 77°F(25°C):800A(5S)		
Charge (Constant Voltage)	Float:13.6 to 13.8V/77°F(25°C)	
	Cycle:14.4 to 14.7V/77°F(25°C) Max Current:25A	

Charge characteristic curve

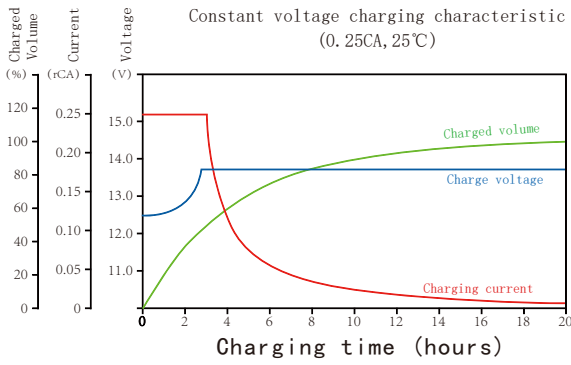

Discharge characteristic (25°C)

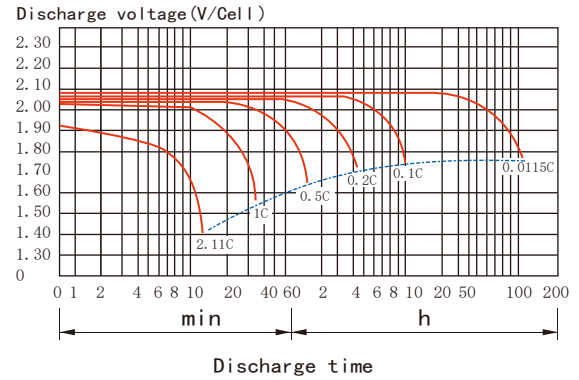

Temperature effects on float life

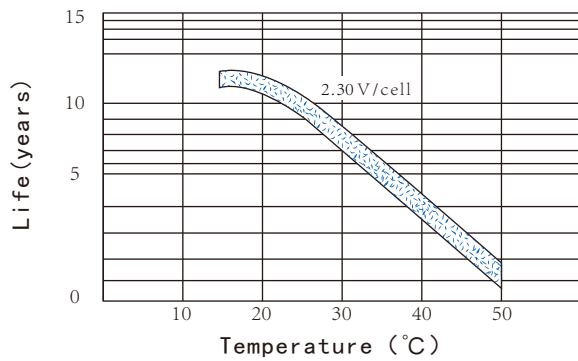

Cycle service life in relation to depth of discharge

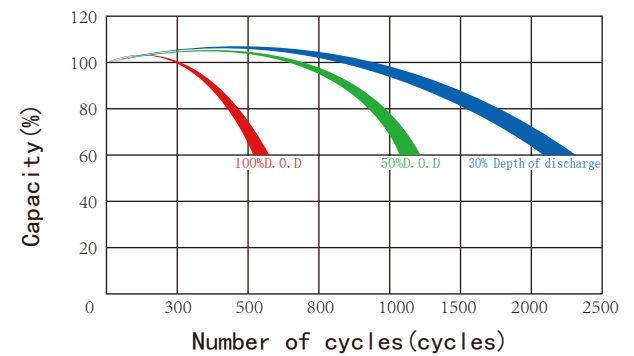

Relationship between charging voltage and temperature

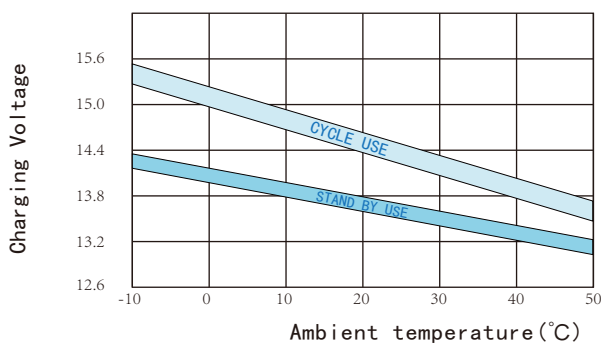

Self-discharge characteristic

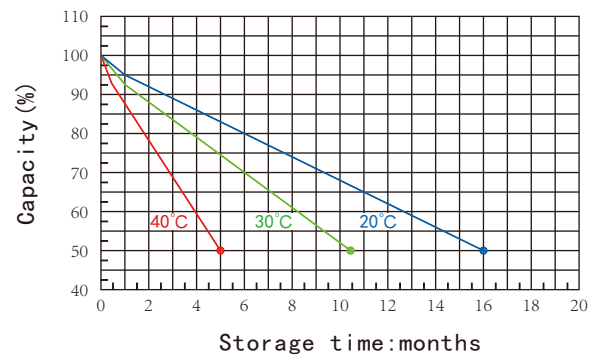

Life characteristics of standby use

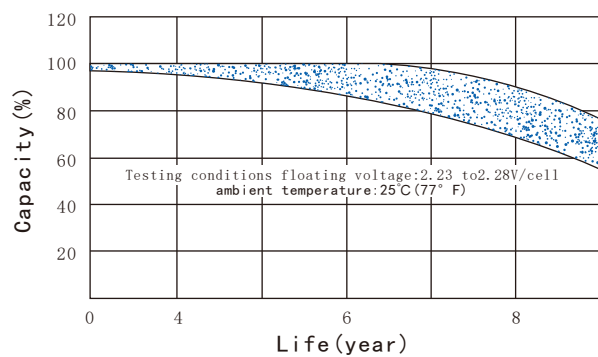

Temperature effects on capacity

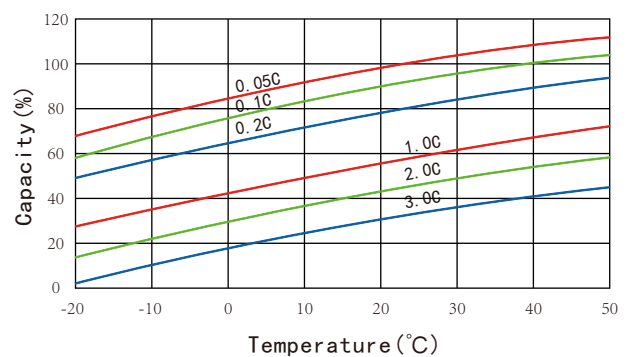

GENERAL FEATURE

- Micro millimeter SiO₂ and H₂SO₄ technology for efficient gas recombination of up to 99% and freedom from electrolyte maintenance or water adding.
- Not restricted for air transport-complies with IATA/ICAO Special Provision A67.
- Can be mounted in any orientation.
- Computer designed lead,calcium tin alloy grid for high power density.
- Long service life,float or cyclic applications.
- Maintenance-free operation.
- Low self discharge.



SPECIFICATION

Nominal voltage	12V
Number of cell	6
Length(mm/inch)	520/20.47
Width(mm/inch)	240/9.45
Height(mm/inch)	218/8.58
Total Height(mm/inch)	222/8.74
Approx.Weight(kg/lbs)	60/132.28

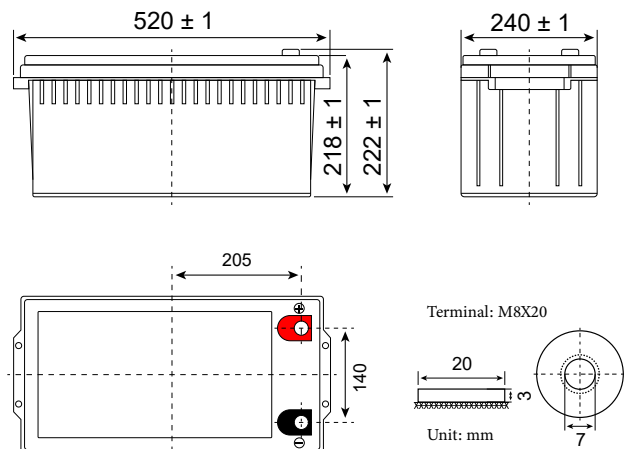

MATERIAL

Component	Positive plate	Negative plate	Container	Cover	Safety valve	Terminal	Separator	Electrolyte
Raw material	Lead dioxide	Lead	ABS	ABS	Rubber	Copper	Fiberglass	Colloidal Silicon

CONFIGURATION

Capacity 77°F(25°C)	100 hours rate (2.3A 11.1V)	230Ah
	20 hours rate (10.5A 10.5V)	210Ah
	10 hours rate (20A 10.5V)	200Ah
	1 hour rate (118A 9.6V)	118Ah
Internal Resistance	Full charged battery 77°F(25°C):6mΩ	
Capacity affected by Temperature (10 hour rate)	104°F(40°C)	102%
	77°F(25°C)	100%
	32°F(10°C)	85%
	5°F(-15°C)	65%
Self-Discharge 68°F(20°C)	Capacity after 3 month storage	90%
	Capacity after 6 month storage	80%
	Capacity after 12 month storage	60%
Max discharge current 77°F(25°C):1000A(5S)		
Charge (Constant Voltage)	Float:13.6 to 13.8V/77°F(25°C)	
	Cycle:14.4 to 14.7V/77°F(25°C) Max Current:60A	

Charge characteristic curve

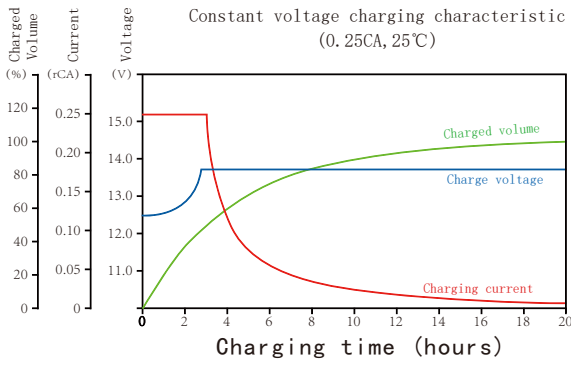

Discharge characteristic (25°C)

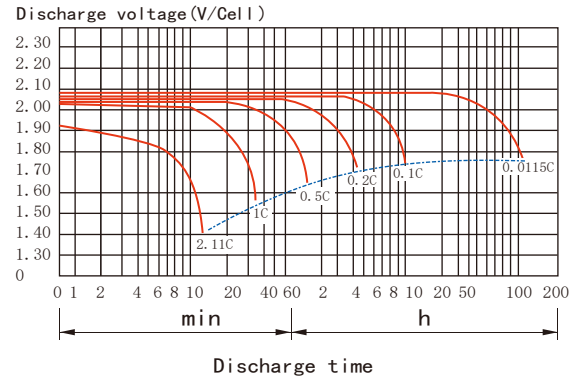

Temperature effects on float life

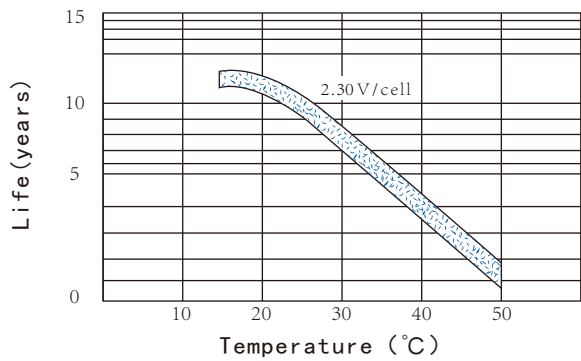

Cycle service life in relation to depth of discharge

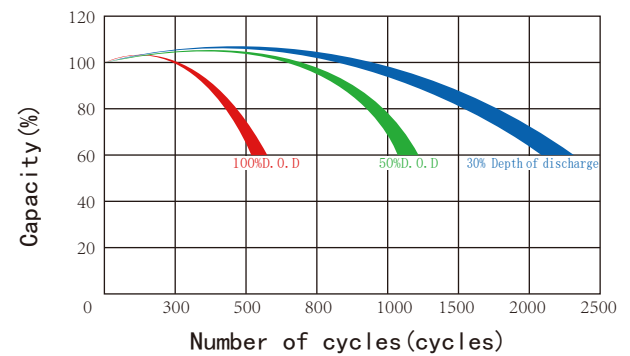

Relationship between charging voltage and temperature

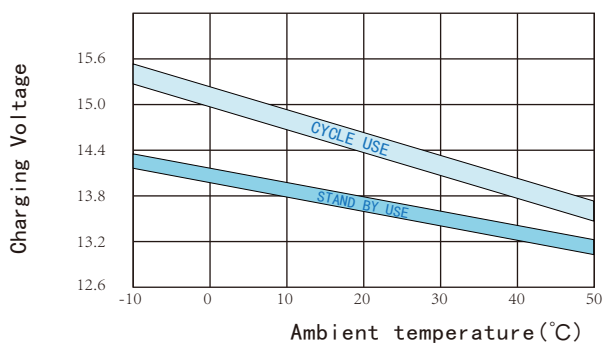

Self-discharge characteristic

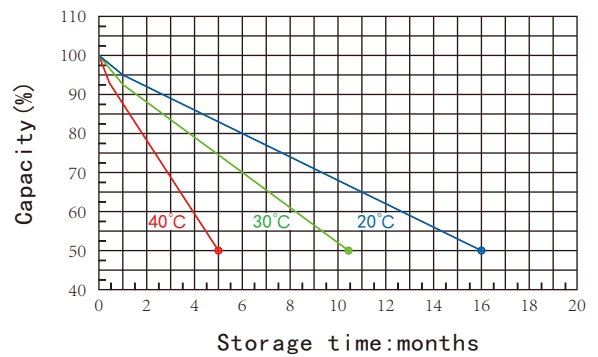

Life characteristics of standby use

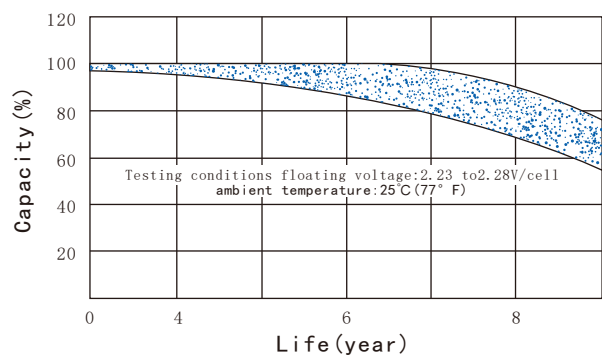

Temperature effects on capacity

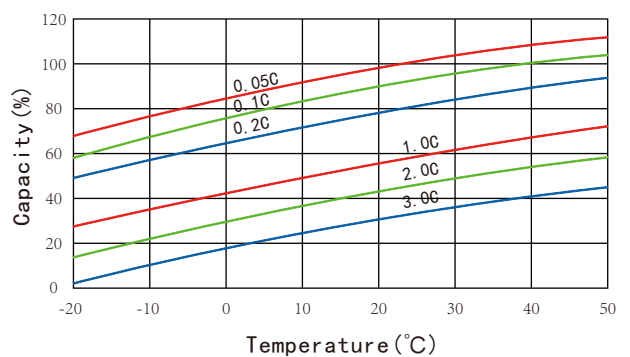

GENERAL FEATURE

- Micro millimeter SiO₂ and H₂SO₄ technology for efficient gas recombination of up to 99% and freedom from electrolyte maintenance or water adding.
- Not restricted for air transport-complies with IATA/ICAO Special Provision A67.
- Can be mounted in any orientation.
- Computer designed lead,calcium tin alloy grid for high power density.
- Long service life,float or cyclic applications.
- Maintenance-free operation.
- Low self discharge.



SPECIFICATION

Nominal voltage 12V
 Number of cell 6
 Length(mm/inch) 520/20.47
 Width(mm/inch) 268/10.55
 Height(mm/inch) 220/8.66
 Total Height(mm/inch) 224/8.82
 Approx.Weight(kg/lbs) 70/154.32

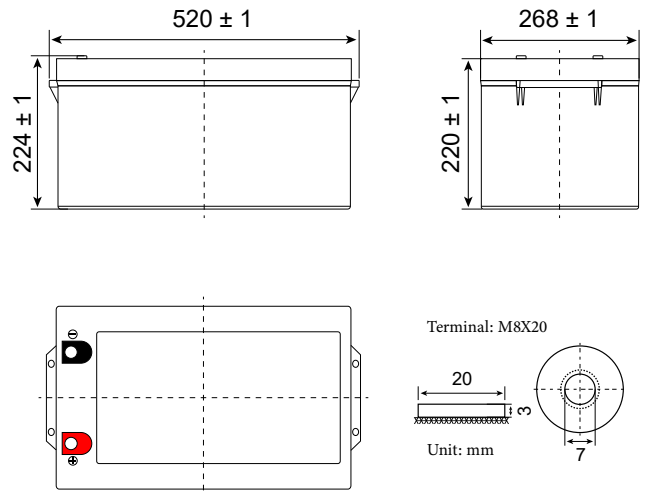

MATERIAL

Component	Positive plate	Negative plate	Container	Cover	Safety valve	Terminal	Separator	Electrolyte
Raw material	Lead dioxide	Lead	ABS	ABS	Rubber	Copper	Fiberglass	Colloidal Silicon

CONFIGURATION

Capacity 77°F(25°C)	100 hours rate (2.9A 11.1V)	290Ah
	20 hours rate (12.5A 10.8V)	250Ah
	10 hours rate (23.8A 10.5V)	238Ah
	1 hour rate (155A 9.6V)	155Ah
Internal Resistance	Full charged battery 77°F(25°C):4.5mΩ	
Capacity affected by Temperature (10 hour rate)	104°F(40°C)	102%
	77°F(25°C)	100%
	32°F(10°C)	85%
	5°F(-15°C)	65%
Self-Discharge 68°F(20°C)	Capacity after 3 month storage	90%
	Capacity after 6 month storage	80%
	Capacity after 12 month storage	60%
Max discharge current 77°F(25°C):1200A(5S)		
Charge (Constant Voltage)	Float:13.6 to 13.8V/77°F(25°C)	
	Cycle:14.4 to 14.7V/77°F(25°C) Max Current:62.5A	

Charge characteristic curve

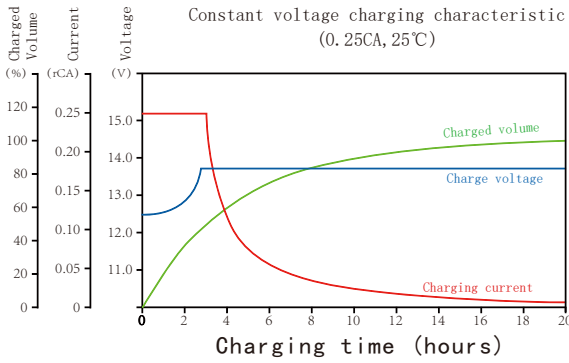

Discharge characteristic (25°C)

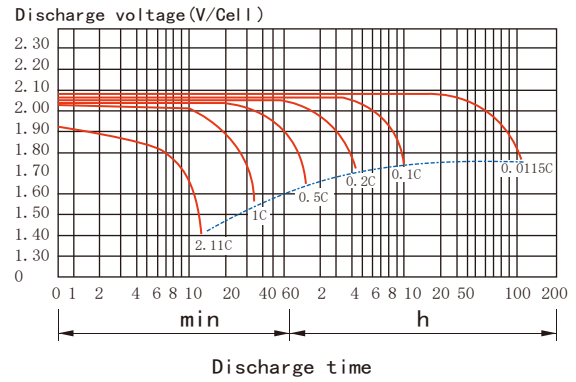

Temperature effects on float life

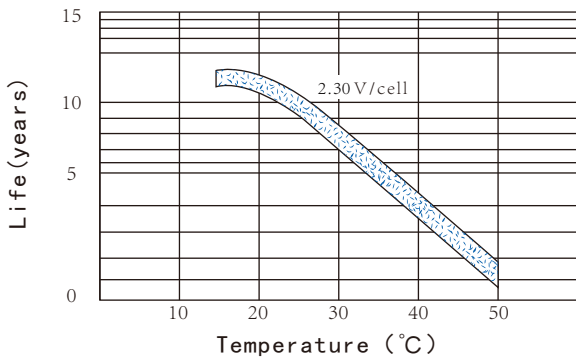

Cycle service life in relation to depth of discharge

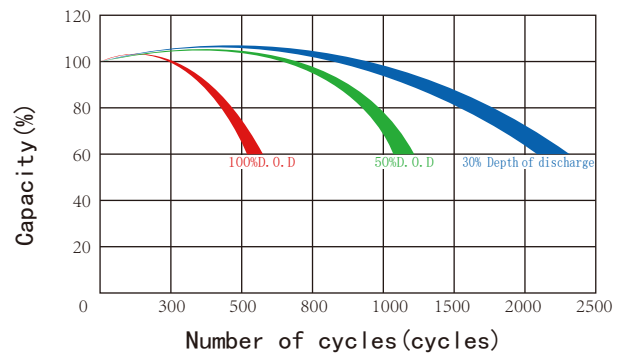

Relationship between charging voltage and temperature

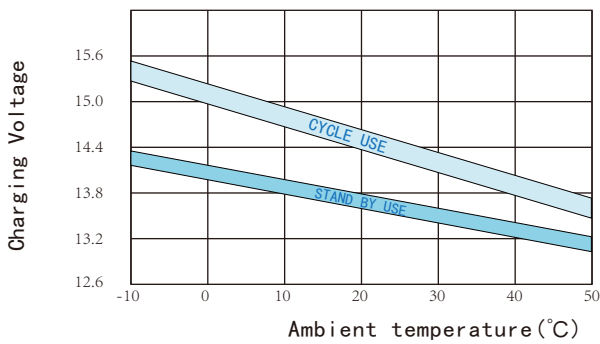

Self-discharge characteristic

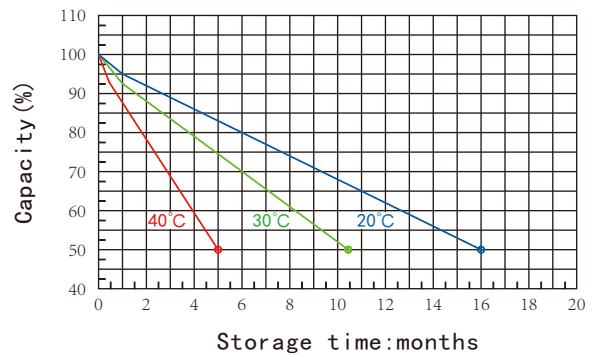

Life characteristics of standby use

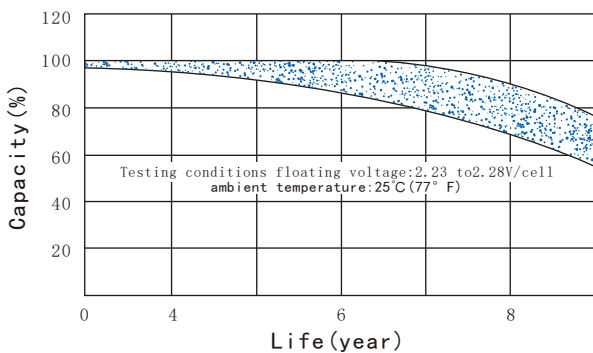

Temperature effects on capacity

