

Haitai **HAI DUN**

HTDESS1500-750/1863
HTDESS1500-1725/3727



Product Features

- High quality LFP batteries, long cycling lifetime(> 6000 times).
- Intelligent BMS enables 3-level monitoring (Pack, Rack, System), guarantee high performance and security
- Large storage capacity, high conversion efficiency, comprehensive efficiency > 85%.
- Prefabricated container can be applied in various scenarios, also reduce installation costs.
- Modular design, flexible to adapt to various kinds of voltage platforms and systems with various capacities.
- multi-level protection strategy and fault isolation measures to ensure safety and stability of energy storage system.
- Equipped with fire protection, thermal management system, monitoring system, leakage protection and other devices to ensure safety of the ESS.
- Easy to operate and maintain ,light workload, low maintenance cost.

ESS Diagrams

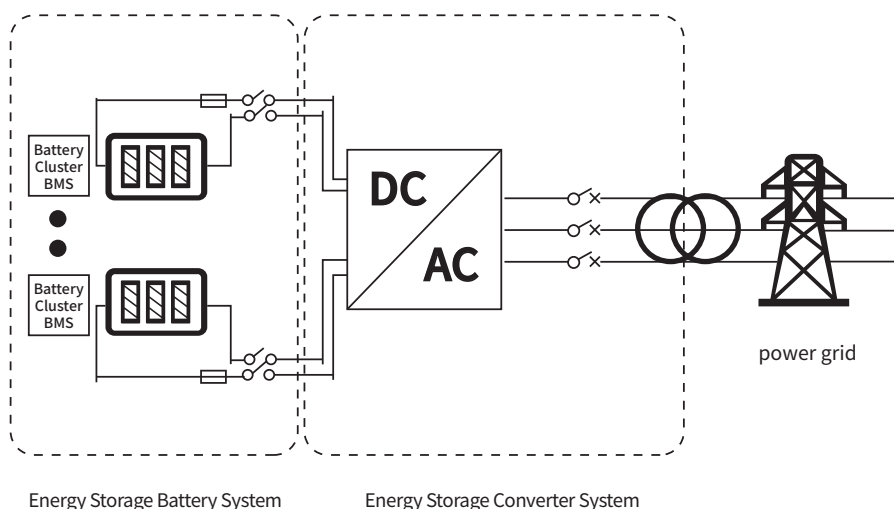

2H System		
Product Model	HTDESS1500-750/1863	HTDESS1500-1725/3727
Battery Capacity (kWh)	1863.7	3727.4
Cell Specification	3.2V/280Ah (0.5P)	
Module Specification	1P8S	
Number of Modules (pcs)	260	520
Number of Racks (pcs)	5	10
Number of Cells (pcs)	2080	4160
Rated Voltage (V)	1331.2	
Voltage Range (V)	1164.8~1497.6	
Rated Current (A)	704.3	1408.5
Voltage Accuracy (FSR)	1%	
Current Accuracy (FSR)	1%	
Temperature Accuracy (°C)	2	
SOC Accuracy	5%	
AC System		
PCS Rated Power (kW)	750	1725
Output Voltage (V)	1725	
Group	Dy11	
Grid Voltage Range (V)	690±15%	690±15%
Rated Current (A)	782.5	1565
Rated Frequency (Hz)	50	
THD	小于 3%	
Transformer Mode	Dry / Oil-immersed transformer	
Other Parameters		
Dimension (L * W * H /mm)	6058*2438*2896	12192*2438*2896
Gross weight (t)	< 30	< 50
Cooling mode	Forced air cooling	
AC Model	Wall-mounted, 2×20kW	Wall-mounted, 4×20kW
Fire supervision system	FM-200 (HFC) , Pipeline type	
Communication Protocols	Ethernet、CAN	
Wireless communication	2G、4G	
Cycle life	>6000 次 (@25°C, EOL80%)	
Protection class	IP54	
Operating temperature	-25~+50°C	
Operating Humidity	0~95%, no condensation	
Altitude	≤ 2000 米	

Note: The product dimensions and parameters may change with product updates and without any notice, please refer to the latest product information