

THREE PHASE HYBRID INVERTER

SunExpert TH8|10|12|15|20K-EU



• FEATURES

100% three-phase unbalanced output, with each phase capable of delivering up to 50% of the rated power

Ac coupling to retrofit Existing solar system

Max. 10 pcs parallel for on-grid and off-grid operation; Support multiple batteries parallel

Support multiple batteries parallel

High voltage battery, higher efficiency

6 time periods for battery charging/discharging

Support storing energy from diesel generator

• PRODUCT CHARACTERISTICS

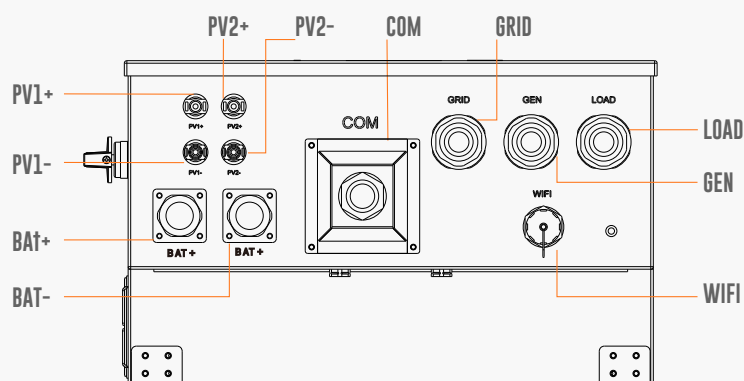

Model	SunExpert TH8K-EU	SunExpert TH10K-EU	SunExpert TH12K-EU	SunExpert TH15K-EU	SunExpert TH20K-EU
PV String Input Data					
Max. DC Input Power (W)	10400	13000	15600	19500	26000
Rated PV Input Voltage (V)	1000				
Start-up Voltage (V)	180				
MPPT Voltage Range (V)	325-850				
Full Load MPPT Voltage Range (V)	600				
Max. DC Input Current(A)	20+20		26+26		
Max. DC Short Circuit Current(A)	30+30		39+39		
No.of MPPT Trackers	2				
No.of Strings per MPPT Tracker	1+1		2+2		
AC Output					
Rated AC Output Power (W)	8000	10000	12000	15000	20000
Max. AC Output Power (W)	8800	11000	14400	16500	22000
AC Output Rated Current (A)	12.2	15.2	18.2	22.8	30.4
Max. AC Output Current (A)	13.4	16.7	19.2	25.0	33.4
Max. Three-phase Unbalanced Output Current (A)	17.8	22	26.8	33.6	44.7
Max. Continuous AC Passthrough (A)	32	40	48	60	80
Peak Power (Off Grid)	1.5 times of rated power, 10 S				
Generator Input/Smart Load/AC Couple Current (A)	12.2/32/12.2	15.2/40/15.2	18.2/48/18.2	22.8/60/22.8	30.4/80/30.4
Power Factor	0.8 leading - 0.8 lagging				
Output Frequency and Voltage	50/60Hz; 3L/N/PE 220/380Vac, 230/400Vac				
Grid Type	Three Phase				
Total Harmonic Distortion	THDi<3% (linear load <1.5%)				
Battery					
Battery Type	Lithium-ion				
Battery Voltage Range (V)	160-700				
Max. Charging Current (A)	37				
Max. Discharging Current (A)	37				
Number of Battery Input	1				
Charging Strategy for Li-Ion Battery	Self-adaption to BMS				
Efficiency					
Max. Efficiency	97.6%				
Euro Efficiency	97.0%				
MPPT Efficiency	99.0%				
Protection					
Anti-islanding Protection	Yes				
PV String Input Reverse Polarity Protection	Yes				
Insulation Resistor Detection	Yes				
Residual Current Monitoring Unit	Yes				
Output Over Current Protection	Yes				
Output Shorted Protection	Yes				
Surge Protection	Yes				
Arc Fault Circuit Interruption (AFCI optional)	Yes				
Over Voltage Protection	Yes				
Certifications and Standards					
Grid Regulation	IEC61727/62116,EN50549-1				
Safety EMC / Standard	IEC/EN 61000-6-1/2/3/4, IEC/EN 62109-1, IEC/EN 62109-2				
General Data					
Operating Temperature Range (°C)	-25 °C ~ +60 °C				
Cooling	Smart Cooling				
Noise (dB)	<45 dB				
Communication with BMS	CAN				
Monitoring mode	WIFI, APP				
Weight (kg)	30				
Size (WxHxD mm)	408×638×237 (Excluding Connectors and Brackets)				
Ingress Protection	Ip65				
Installation Style	Wall-mounted				
Warranty	5 Years (10 Years Optional)				

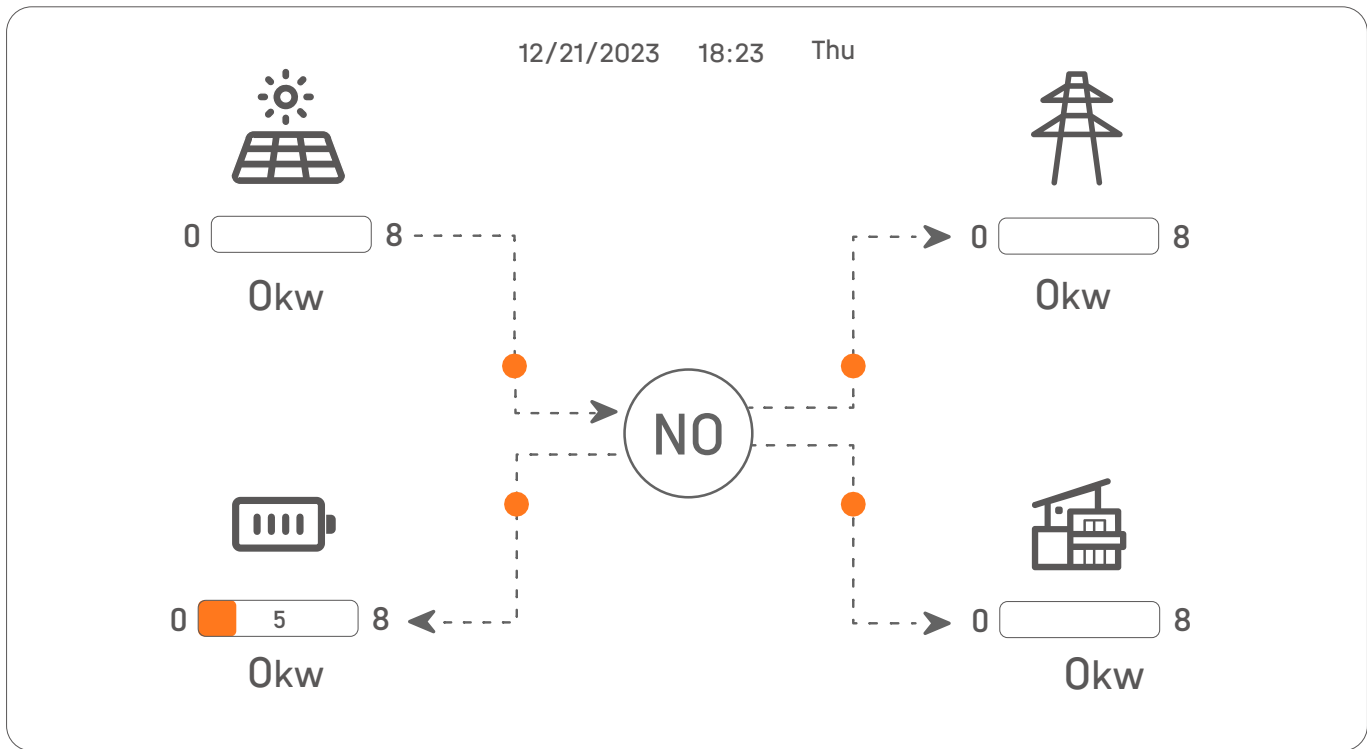

Lcd Display Icons

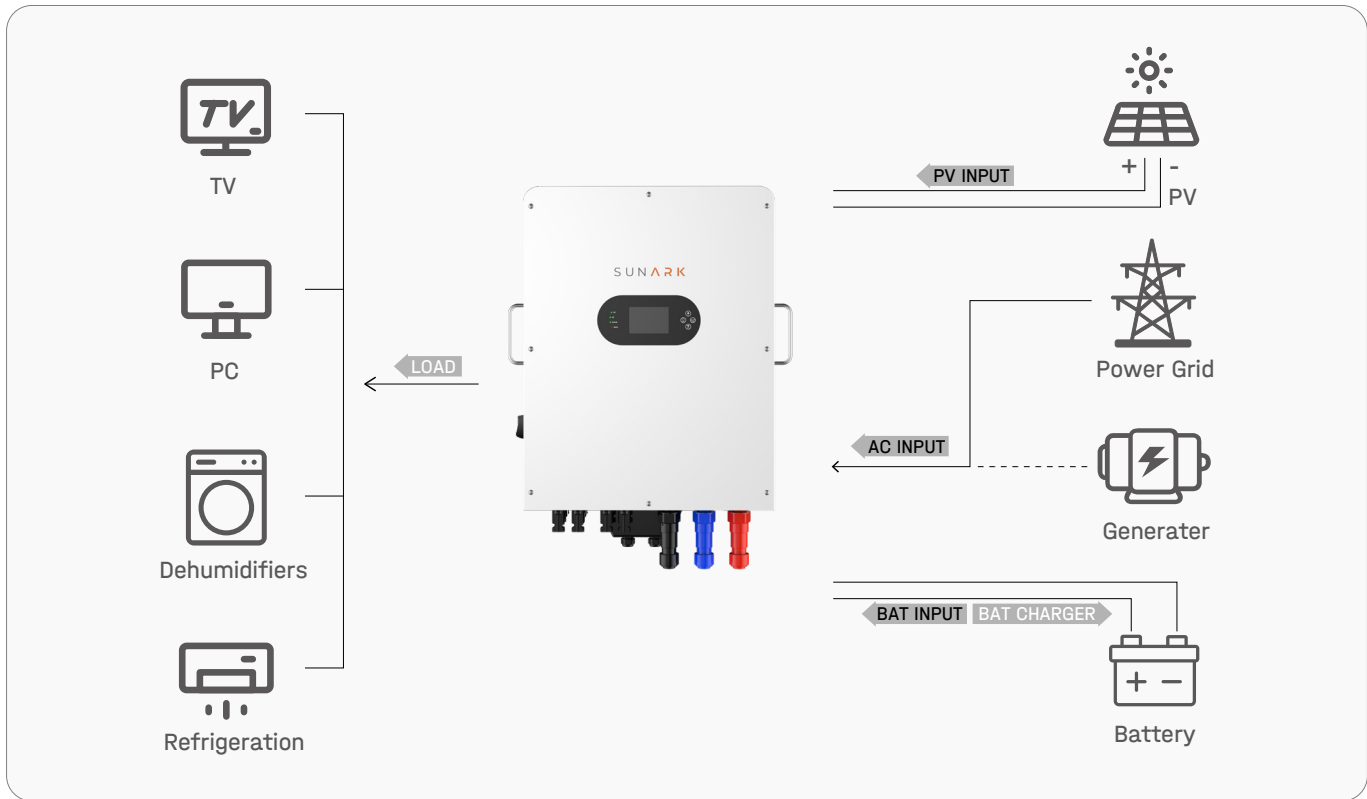

Basic System Architecture