

EU118 Series

5~12KW | Three Phase | 380VAC

EU118 is brand new three phase hybrid inverter with low battery voltage 48V, ensuring system safe and reliable. With compact design and high-power density, this series supports 1.3 DC/AC ratio, saving device investment. It supports three phase unbalanced output, extending the application scenarios. Equipped with CAN port (x2) BMS and parallel, x1 RS485 port for BMS, x1 RS232 port for remotely control, x1 DRM port, which makes the system smart and flexible.



- 100% unbalanced output, each phase max. output up to 50% rated power
- Max. 6 pcs parallel for on-grid and off-grid operation
- AC couple to retrofit existing solar system
- Support multiple batteries parallel
- Max. charging/discharging current of 240A
- Support storing energy from diesel generator
- 48V low voltage battery, transformer isolation design
- IP65 water-proof and dust-proof
- "Time of use" function: a maximum of 6 time segments can be set
- Wifi monitoring

Back panel description

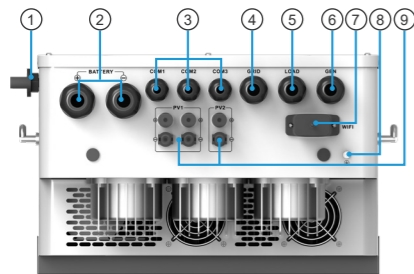

1. DC switch
2. Battery input connectors
3. BTS terminals, BMS terminals, load monitor terminals, dry contact terminals, CAN communication terminals, USB terminal and cover
4. Circuit breaker of Grid
5. Load
6. Generator input
7. WiFi Interface
8. Ground
9. PV input with two MPPT

Solar system connection

Basic

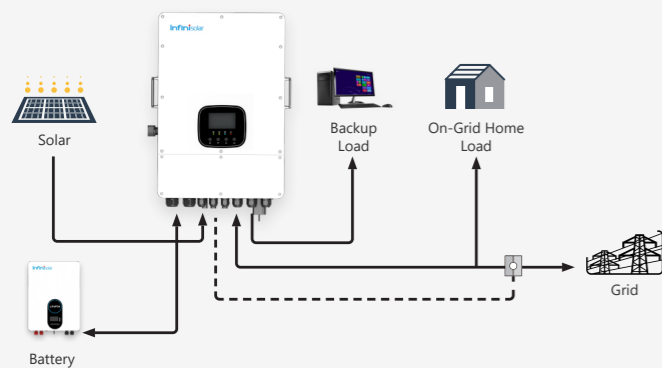

With Generator

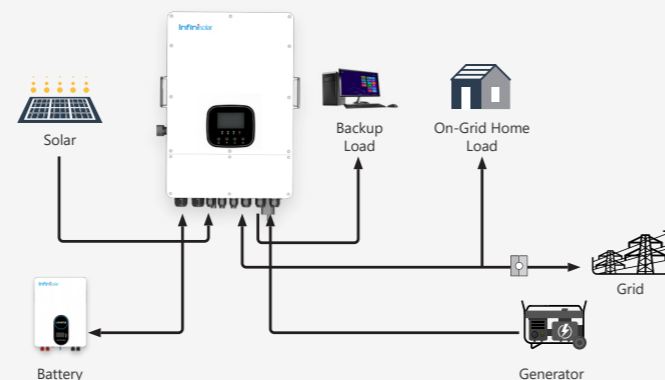

Specification

MODEL	EU118-5KL3-EU	EU118-6.5KL3-EU	EU118-8KL3-EU	EU118-10KL3-EU	EU118-12KL3-EU
Rated power	5000W	6500W	8000W	10000W	12000W
BATTERY INPUT DATA					
Battery type	Lead-acid battery / Lithium battery				
Battery voltage	48V				
Battery voltage range	40~60V				
Charging curve	3-stage adaptive with maintenance/Equalization				
Charging Strategy for Li-Ion Battery	Self-adaption to BMS				
Over-current protection/ Over-temperature protection	Yes / Yes				
Maximum charging/discharging power	5000W	6500W	8000W	10000W	12000W
Maximum charging/discharging current	120A	150A	190A	210A	240A
PV STRING INPUT DATA					
Max. DC Input Power	6500W	8450W	10400W	13000W	15600W
Rated PV Input Voltage	550V				
Maximum DC voltage	800V				
Start-up Voltage	160V				
Minimum voltage for grid connection	310V				
Full Load DC Voltage Range	350-650V				
Enter high voltage error recovery point	800V				
MPPT voltage range	200~650V				
Maximum input current	15A/15A		26A/13A		
No.of MPP Trackers	2				
No.of Strings per MPP Tracker	1+1		2+1		
AC INPUT/OUTPUT DATA					
Rated AC Input/ Output Power	5000W	6500W	8000W	10000W	12000W
Max AC Input/ Output Power	5500W	7150W	8800W	11000W	13200W
AC Input/ Output Rated Current	7.6/7.2A	9.8/9.42A	12.1/11.6A	15.2/14.5A	18.2/17.4A
Max AC Input/ Output Current	8.4/8A	10.8/10.4A	13.4/12.8A	16.7/15.9A	20/19.1A
Max. Three-phase Unbalanced Output Current	11.4/10.9A	14.7/14.1A	18.2/17.4A	22.7/21.7A	27.3/26.1A
Power Factor Adjustment Range	0.8 leading to 0.8 lagging				
Rated Input/Output Voltage	220/380,230/400Vac				
Rated Input/Output Grid Frequency/Range	50/60;45~55/55-65				
Grid Type	Three Phase				
Total Harmonics Current Distortion (THDi)	<3% (of nominal power)				
DC Current Injection	<0.5% In				
EFFICIENCY					
Max. Efficiency	≥97.5%				
Euro Efficiency	97.0%				
PROTECTION					
Integrated	PV Arc Fault Detection, Anti-islanding Protection, PV String Input Reverse Polarity Protection, Insulation Resistor Detection, Residual Current Monitoring Unit, Output Over Current Protection, Output Shorted Protection				
Surge Protection	DC Type III/AC Type III				
Overvoltage Category	DC Type II/AC Type III				
GENERAL DATA					
Operating Temperature Range (°C)	-20°C to +60°C, >45°C Derating				
Cooling	Smart cooling				
Noise (dB)	≤55dB				
Communication with BMS	Wi-Fi/USB/GPRS/RS485/CAN				
Machine Dimension (W*H*D)(mm)	444*654.2*259.2				
Package Dimension (W*H*D)(mm)	567*816*404				
N.W(kg)	35				
G.W(kg)	37				
Protection Degree	IP65				
Installation Style	Wall-mounted				
Warranty	5 Years the Warranty Period Depends the Final Installation Site of Inverter, More Info Please Refer to Warranty Policy				

CERTIFICATION & STANDARDS

CE-EMC+LVD (EN6100-6-3, EN6100-6-1+EN IEC 62109-1, EN IEC 62109-2); CE-LVD(EN 62477-1) ; IEC 60529; EN50549-1; Poland Type A, (NC RfG:2016, PSE:2018, PTPiREE:2021)C10/C11; UNE217001-2020; UNE217002-2020, NTS-631 (Type A); G98+G99