

STR Series

Lithium Battery

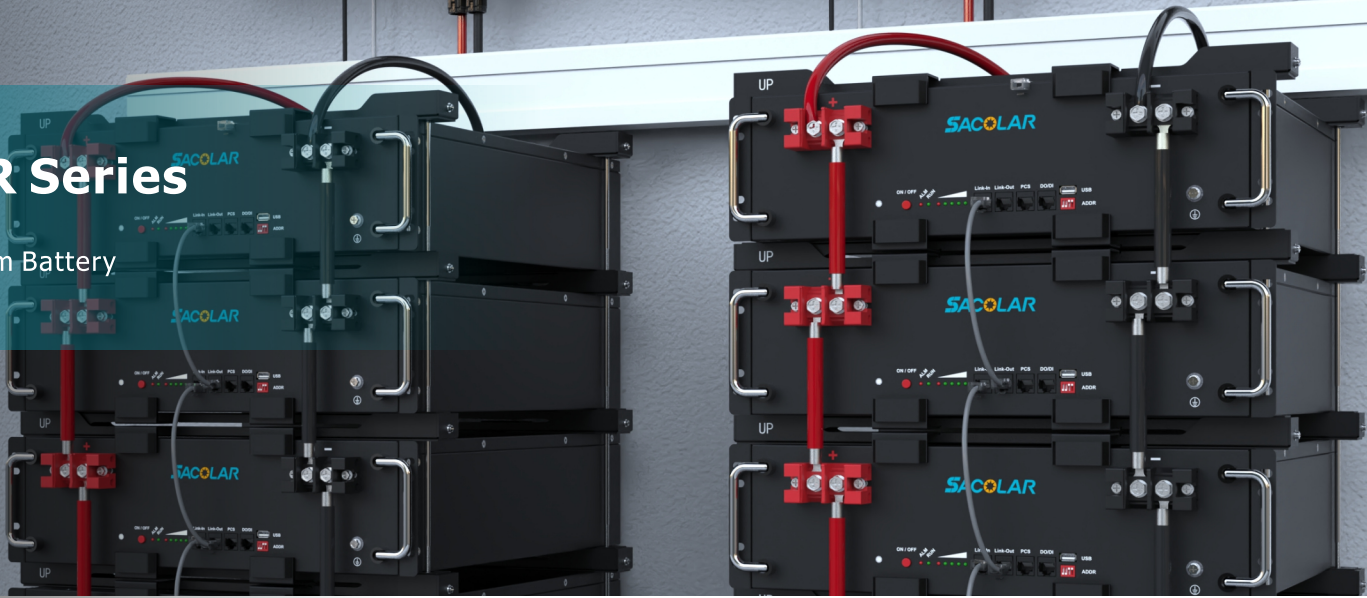

Main Features



- Capacity 5.5KWh,51.2V.
- Cycle life 6000(0.2C/0.2C).
- Intelligent BMS, with full protection.
- Parallel up to 12 units, all of them can be turned on/off with one click.
- Battery can be charged automatically when it over discharged.
- Low self-consumption, <1.5Ah per month after power off.
U-diskupgrade+Remote upgrade+PCupgrade.
- With upper computer software for failure self diagnose.

Port Description

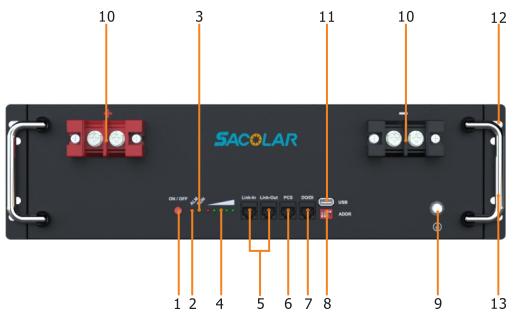

- | | |
|---------------------|---------------|
| 1. ON/OFF | 2. ALM |
| 3. RUN | 4. SOC |
| 5. LINK-In/LINK-Out | 6. PCS |
| 7. DO/DI | 8. ADDR |
| 9. GND | 10. Battery ± |
| 11. USB | 12. Hanger |
| 13. Handle | |

Installation Style



Bracket installation



Cabinet installation

Model	STR5.5L-A1
Nominal Voltage	51.2V
Rated Capacity	106Ah
Rated Energy	5.5kWh
Working Voltage Range	40-58.4V
Discharge Cut-off Voltage	40V
Parallel Max. Units	12Units
Max. Charge Current	100A
Max. Discharge Current	100A
Cycle Life	25±2°C, 0.2C/0.2C, 6000 cycles
IP Rating	IP20
Dimension	440*540*130.5mm
Communication BMS	RS485/CAN
Warranty	5 Years
Weight	48kg
Operation Temperature Discharge	-20~55°C
Operation Temperature Charge	0~55°C
Storage Environment	-20~55°C, 10~90%RH
Certification	CE(EMC)/UN38.3/MSDS/ROHS/IEC62619
Upgrade Method	U-disk upgrade+Remote upgrade+PC upgrade

Parallel wiring

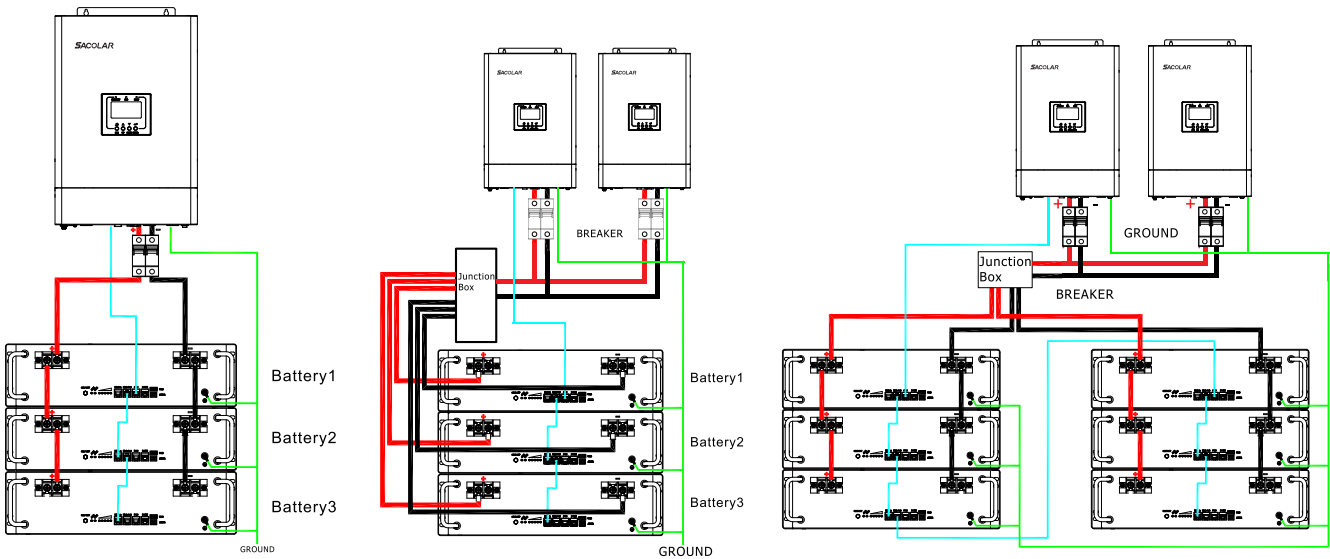

Capacity expansion

Power expansion

Capacity and power expansion