



SIGMA II

Significant savings

Sigma II system combines the installation advantages with the cost advantages of steel components. The galvanized mounting system stands out due to its simple, functional design. Cap profile posts contribute to a higher load-bearing capacity and stability while reducing material requirements.

Maximum service life

A fundamental feature of the Sigma II is its long service life. The special coating provides effective and long-term protection. Therefore a significantly higher corrosion resistance is guaranteed, providing a maximum life span for the system.

Excellent flexibility

As a dual post mounting system, the Sigma II is perfectly suited for flexible module configurations. Depending on the project requirements, it can be installed using various foundations, such as ramming posts, earth screws or foot plates for concrete. An adjustable connection between the rafter and module rail enables installation on terrains with East/West slopes.

Environmentally friendly

The system is developed and produced under certified sustainability standards. In addition, the components are recyclable and can be easily disassembled.



Ground mount



Agri-PV



Framed modules



Unframed modules



Portrait orientation



Landscape orientation



Bifacial modules



Glass-glass modules



10
Years
Warranty

Application	Ground mount
Module types	All monofacial and bifacial options, framed or lamintes Optimized bifaciality in accordance with module manufacturer requirements
Module layout	Multiple configurations, table length more than 40 m, depending on local temperature range
Module orientation	Portrait/vertical, landscape/horizontal
Module inclination	According to project requirements
Ground clearance	Various
Ground slope	Up to 10° East/West (Option 2)
Post spacing	According to static calculation
Standards	Eurocode 1 – Actions on structures Eurocode 3 – Measurement and construction for steel construction
Supporting profiles	Steel (S 355 / S350 GD)
Ramming posts	Cap profile posts
Small parts	Geomet-coated steel, hot-dip galvanized steel Stainless steel (project specific V2A/V4A) Extruded aluminium (EN AW 6063 T66)
Bonding	Low-impedance resistance connections between the components
Warranty	10 years ¹

CONFIGURATION	MODULES	FOUNDATION	MODULE FASTENING
---------------	---------	------------	------------------

Sigma II
2-4 portrait

Framed, unframed
& bifacial
modules

Suitable for
all types

Clamps,
screws,
rivets



Sigma II
3-8 landscape

Clamps,
screws



Connection detail: leg - rafter



Connection detail: post

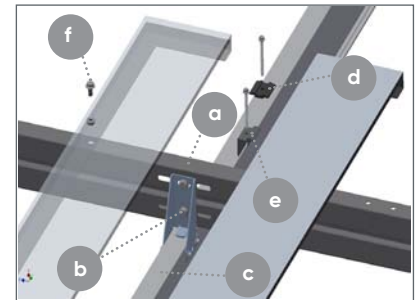

Sigma II - Option 1

- a Module support
- b Cross rail connector
- c Rafter
- d Module clamp
- e Module end clamp
- f Bolted connection

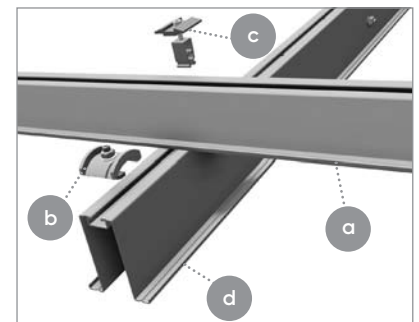

Sigma II - Option 2

- a Module support rail
- b Module support clamp
- c Module clamp with Clickstone
- d Rafter