

4:1

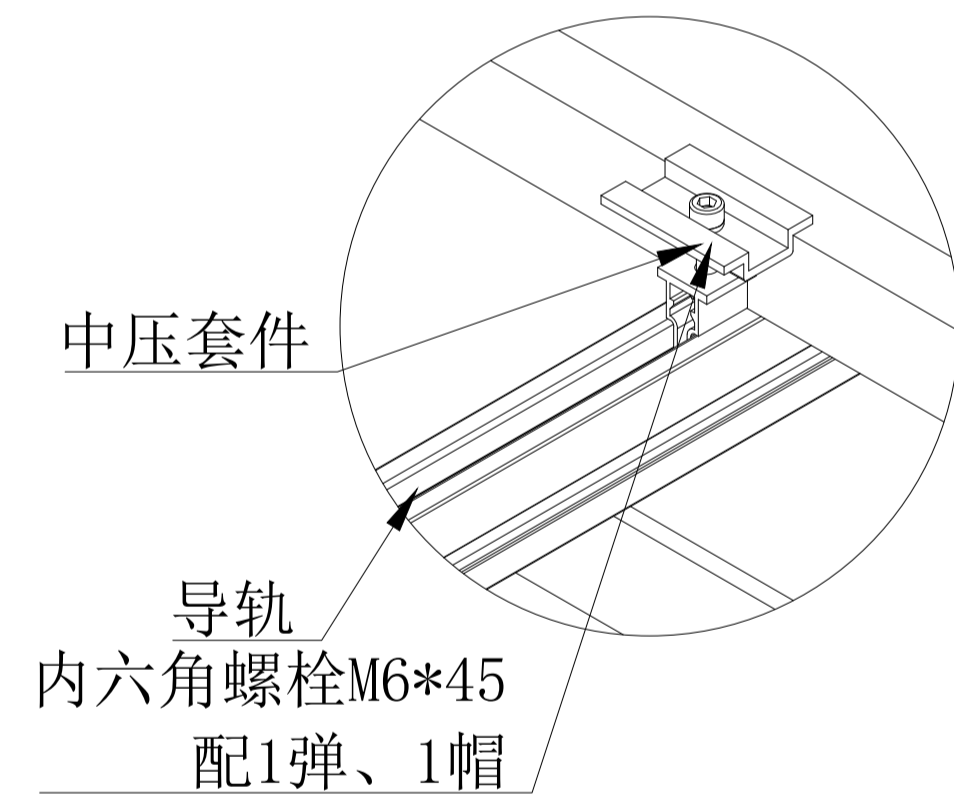

中压安装示意图
Mid clamp

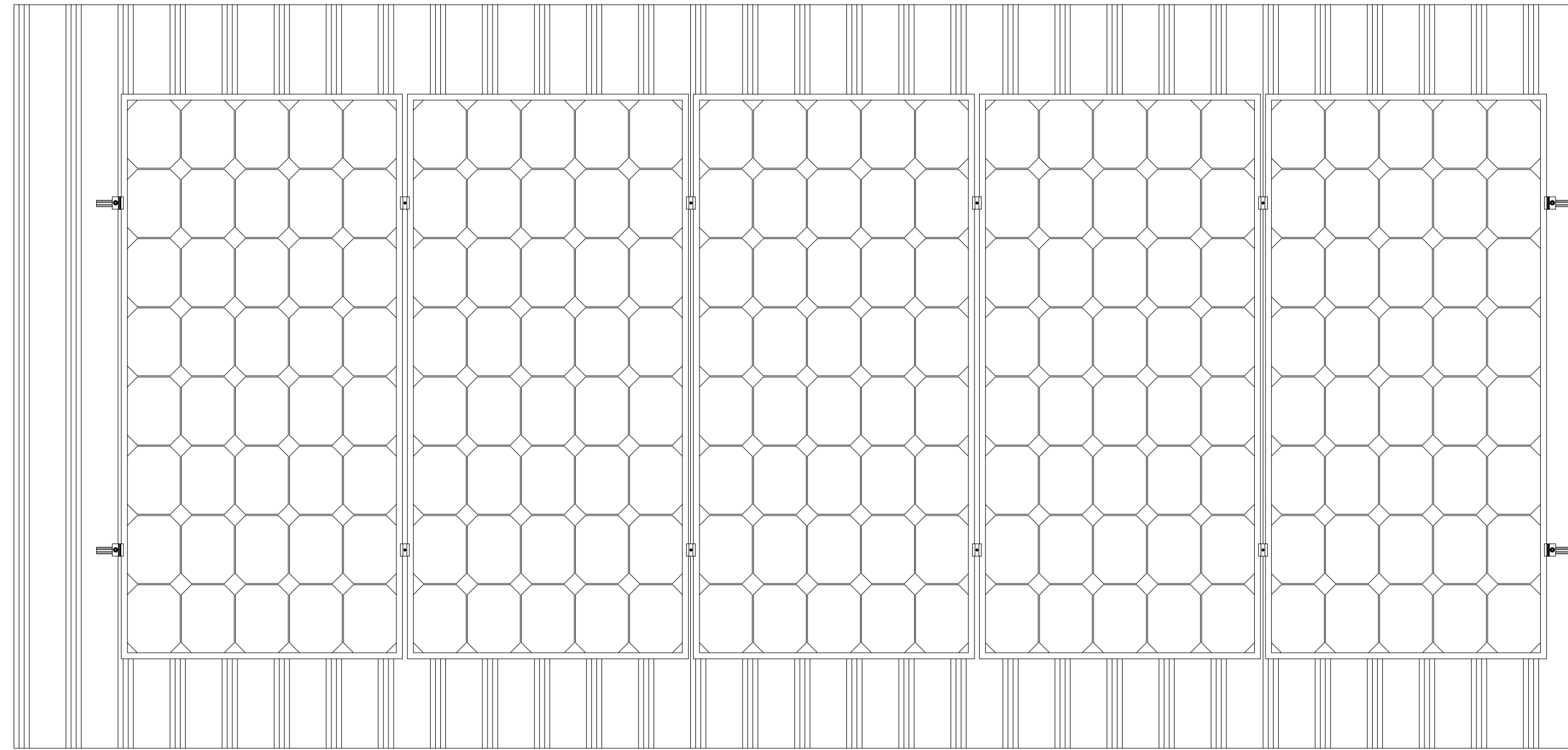
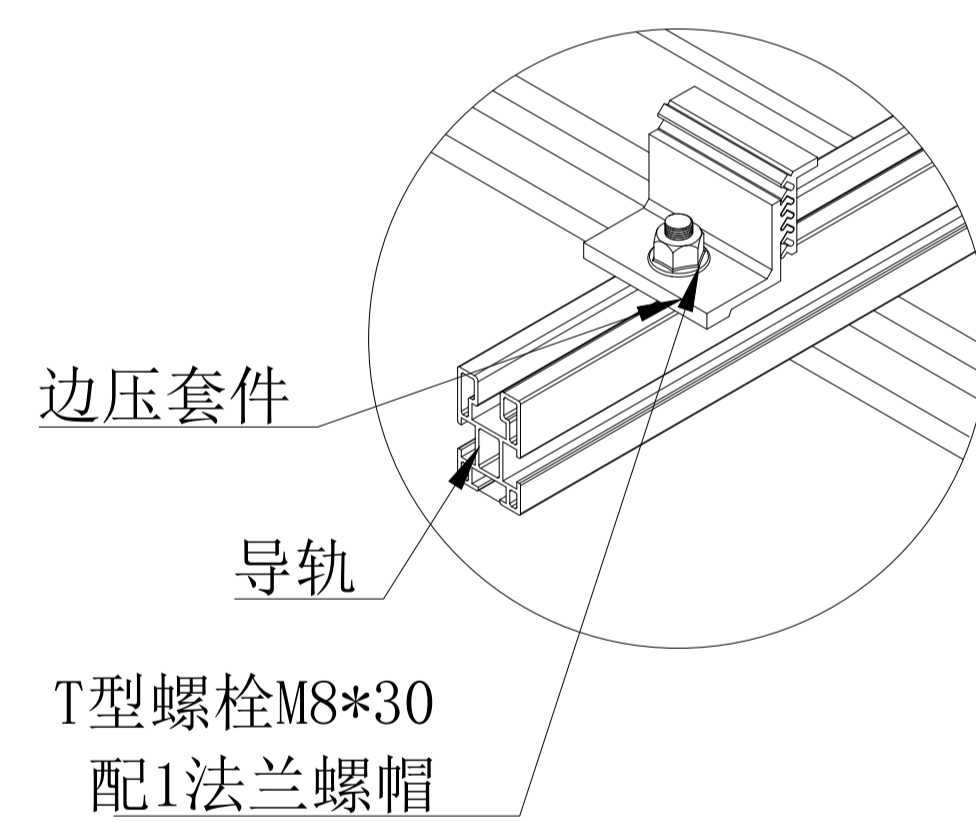

边压安装示意图
End-clamp

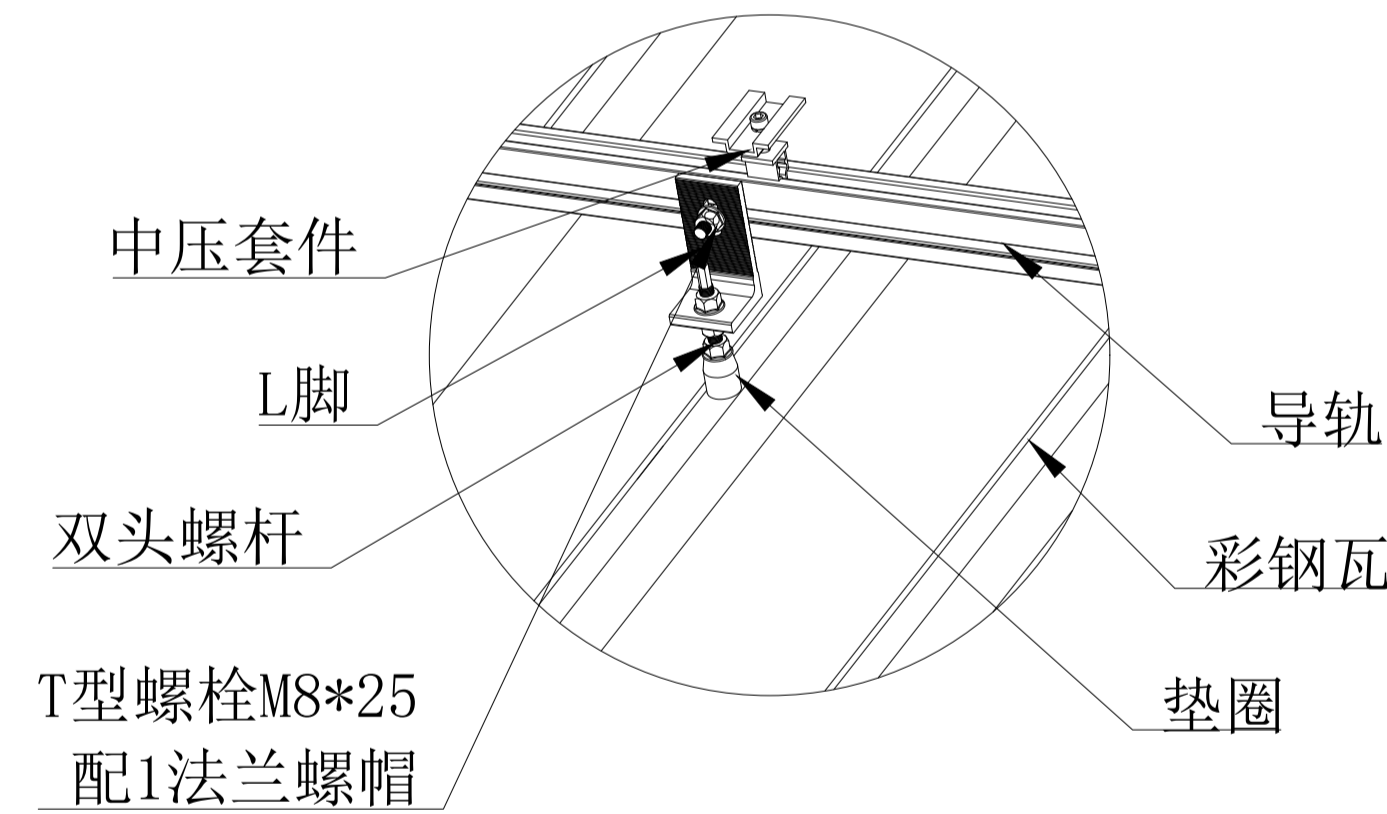

L脚安装示意图
L-feet installation

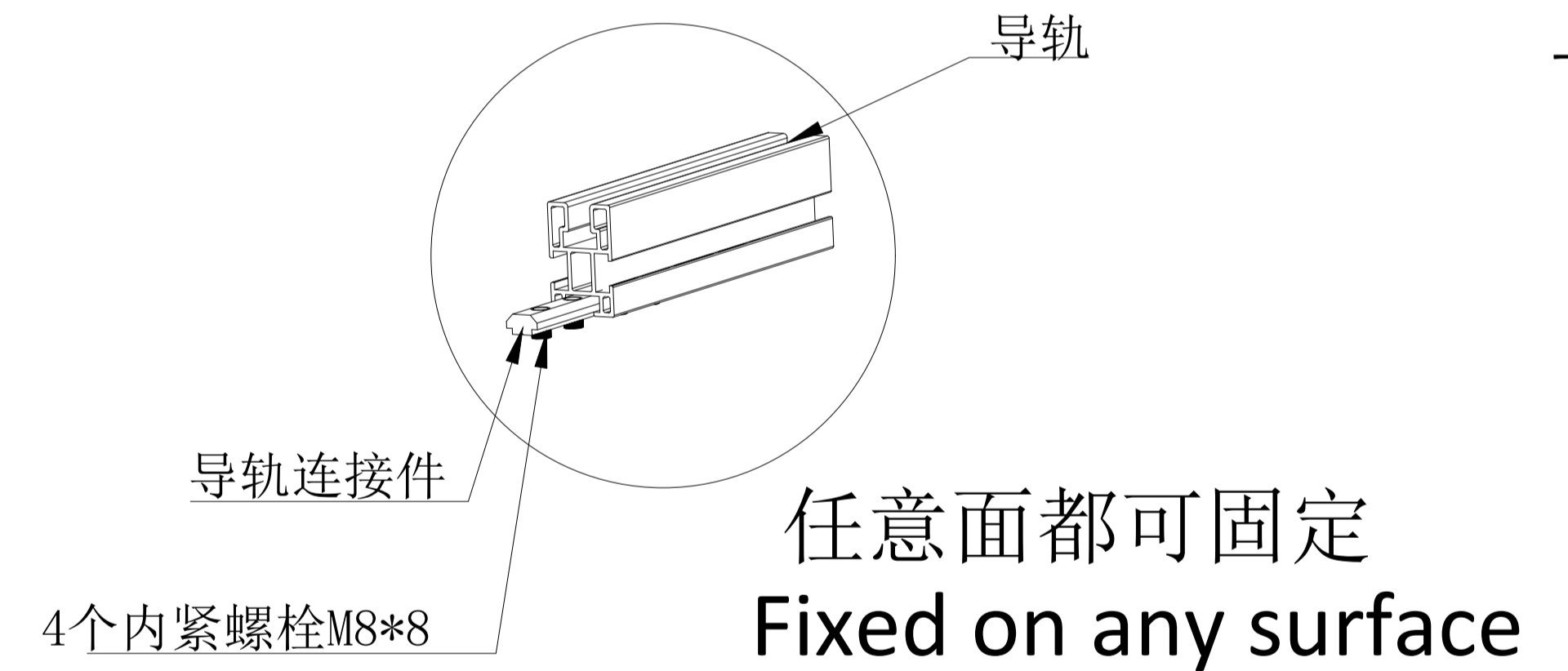

导轨连接件安装示意图
Installation of guide rail connectors

任意面都可固定
Fixed on any surface

说明explain:

1. 此图为1*5安装示意图;
2. 支架现场堆放时, 应不少于3个支点, 薄板长构件应适当增加支点, 防止构件变形;
3. 单位:mm。

项目名称 Project Name:	设计 design:	审核 Auditing:
组件尺寸 Component dimensions:	2278*1134*35	比例 Unit: 1:1
组件瓦数 Component wattage:	570W	单位 Unit: mm
组件数量 Component Number:	5pcs	Jiangsu Yuma Solar Co., Ltd.

项目 Item	名称 Description	材质 Material	长度 Specification	数量 Qty
1	导轨 Rail	AL6005-T5	5950mm	2pcs
2	导轨连接件 Rail Connector	AL6005-T5	100mm	0sets
3	L脚 L-Feet kit	AL6005-T5	40mm	14sets
4	中压 Mid clamp kit	AL6005-T5	50mm	8sets
5	边压 End clamp kit	AL6005-T5	50mm	4sets
6	接地片 Grounding clip	SUS 304		12pcs

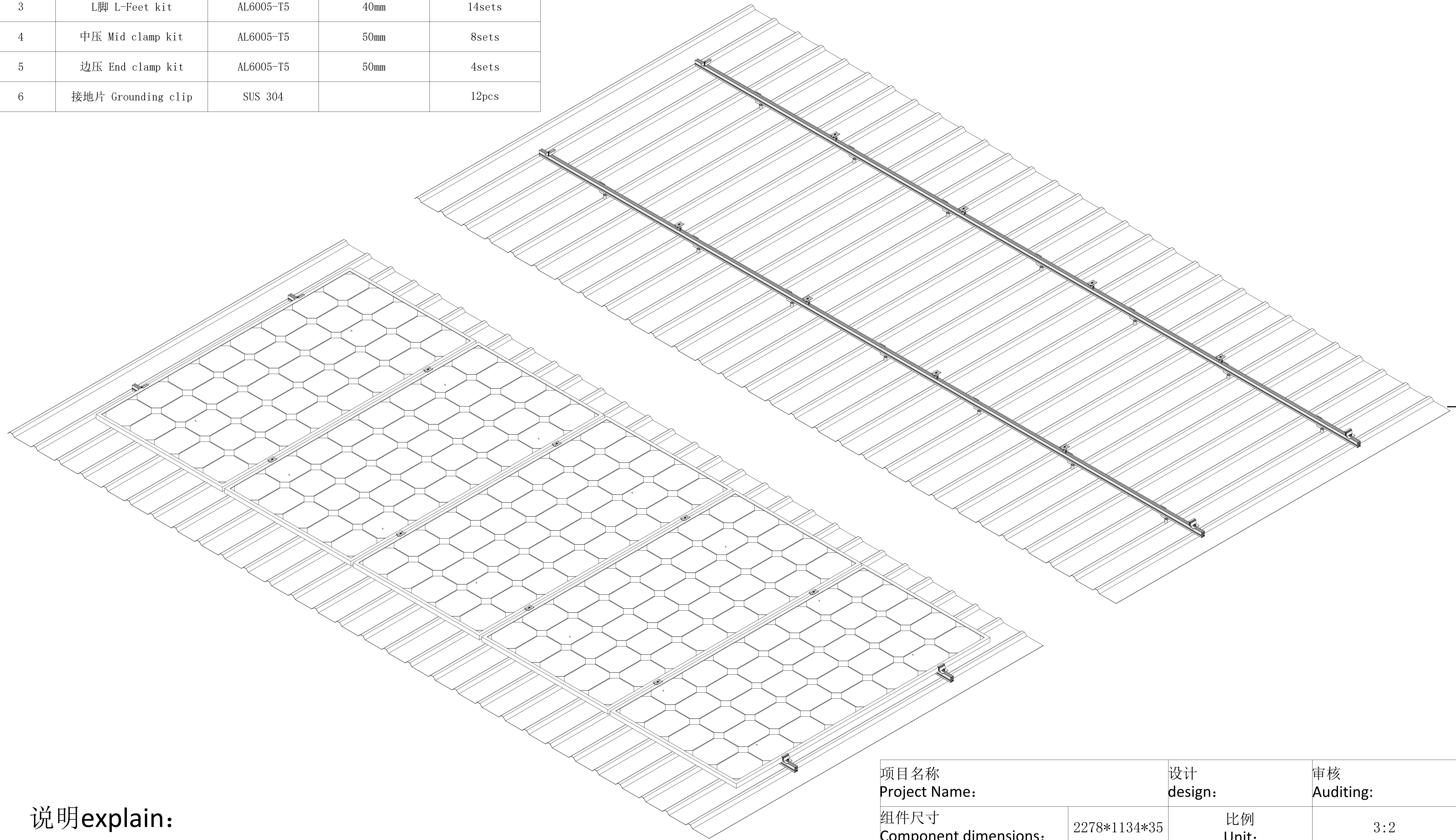

说明explain:

1. 此图为1*5安装示意图;
2. 支架现场堆放时, 应不少于3个支点, 薄板长构件应适当增加支点, 防止构件变形;
3. 单位:mm。

项目名称 Project Name:	设计 design:	审核 Auditing:
组件尺寸 Component dimensions:	2278*1134*35	比例 Unit: 3:2
组件瓦数 Component wattage:	570W	单位 Unit: mm
组件数量 Component Number:	5pcs	Jiangsu Yuma Solar Co., Ltd.