



TS-M10/120G

Monocrystalline Module Bifacial Dual Glass

465W-485W

485W
Maximum Power Output

22.47%
Maximum Module Efficiency

0~+3%
Power Output Guarantee

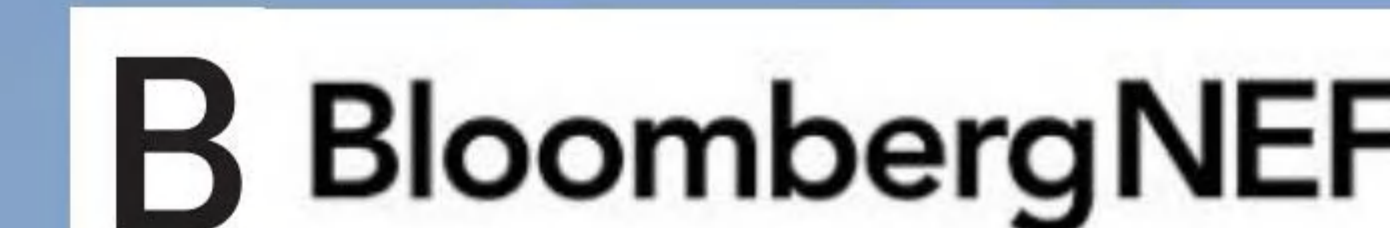
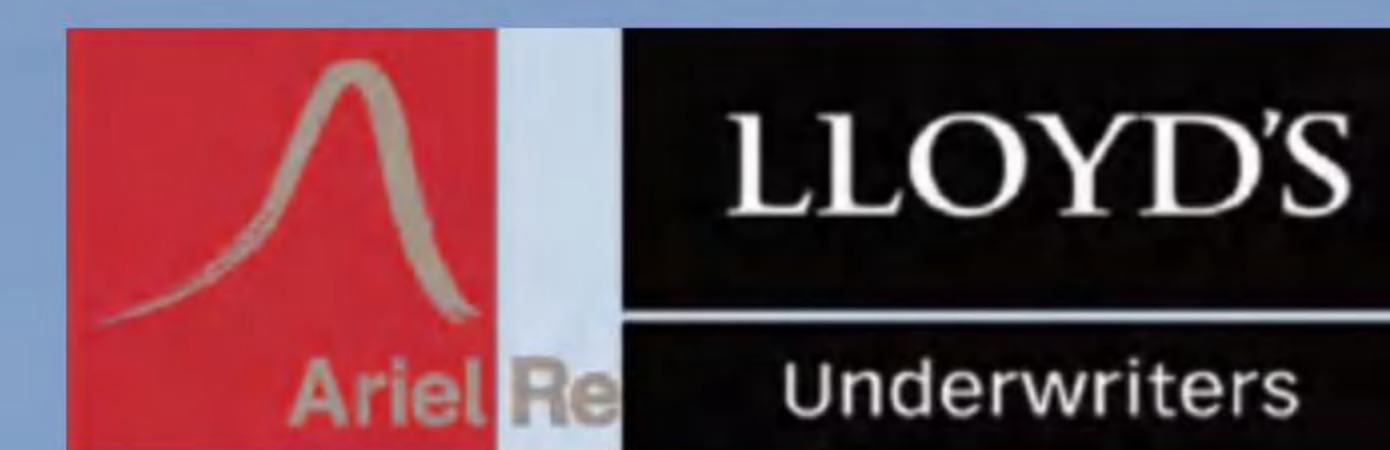

N-Type

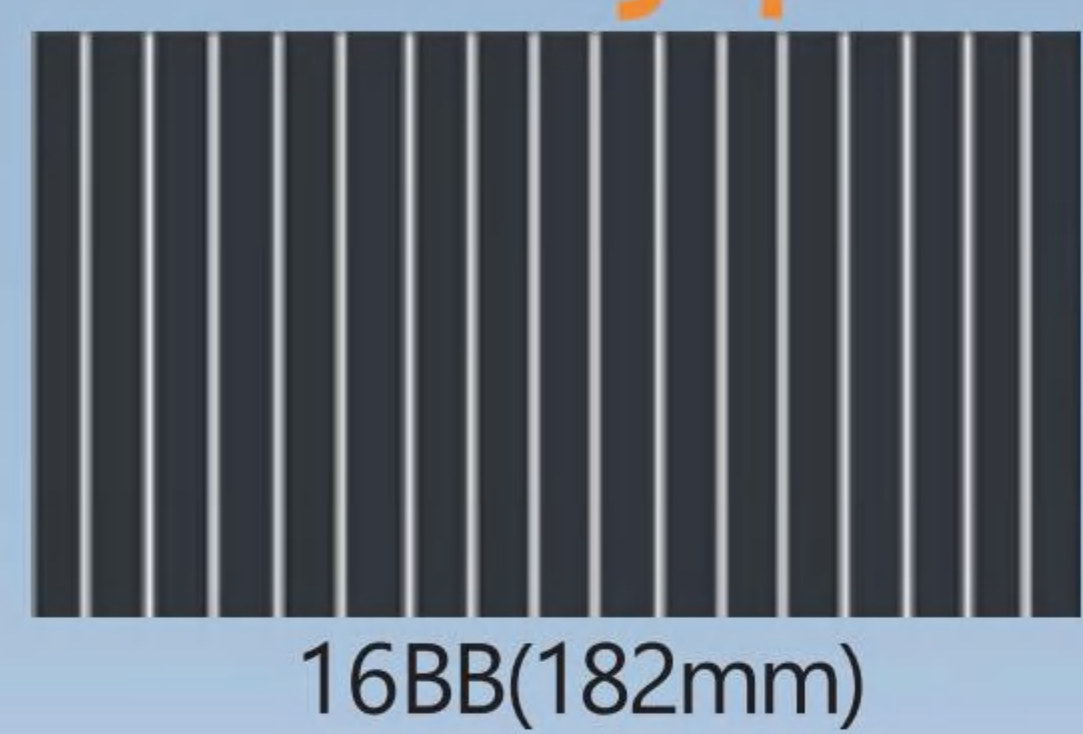

16BB(182mm)

- **FIRE CLASS A**
Maximum fire protection through double glazing according to the highest safety requirements
- **REINSURANCE COVERAGE**
Taoistic is reinsured for 30 years of performance guarantee



High quality silicon wafers guarantee high power module output and excellent cost-effectiveness, making it an ideal choice for large power plants



Selected packaging materials and strict process plans to ensure component PID resistance



Lower oxygen and carbon content leads to lower LID



Adapt to harsh outdoor environments through weather resistance tests such as sand and dust, salt spray, and ammonia gas



The design of series and parallel connection reduces the series resistance r_s of components, reduces internal electrical performance losses, and improves the power generation capacity of the system end



Our company has concluded a reinsurance agreement with Ariel Re - Lloyd's syndicate 1910. Please see <http://verification.arielre-cleanenergy.com>

Deliver Reliable Performance Over Time

- manufacturer of crystalline silicon photovoltaic modules
- Fully automatic facility and world-class technology
- Rigorous quality control to meet the highest standard: ISO9001:2015, ISO14001: 2015 and ISO45001: 2008
- Tested for harsh environments (salt mist, ammonia corrosion and sand blowing test: IEC 61701, IEC 62716)
- Long term reliability tests
- 2x100% EL inspection ensuring defect-free modules
- Fire class1 certificate for ITALY

WARRANTY

- 12 years product warranty
- 30 years performance warranty

Linear Performance Warranty

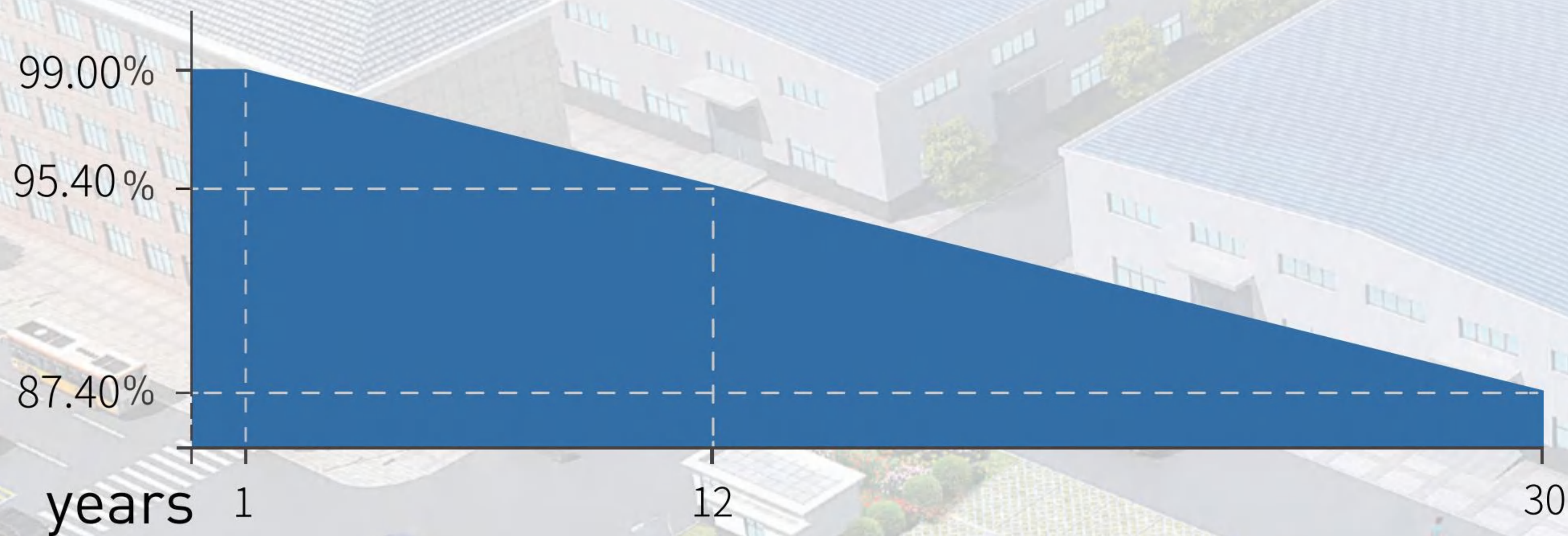

12 Years Product Warranty 30 Years Linear Power Warranty

* Please refer to standard warranty for details

Product Certification

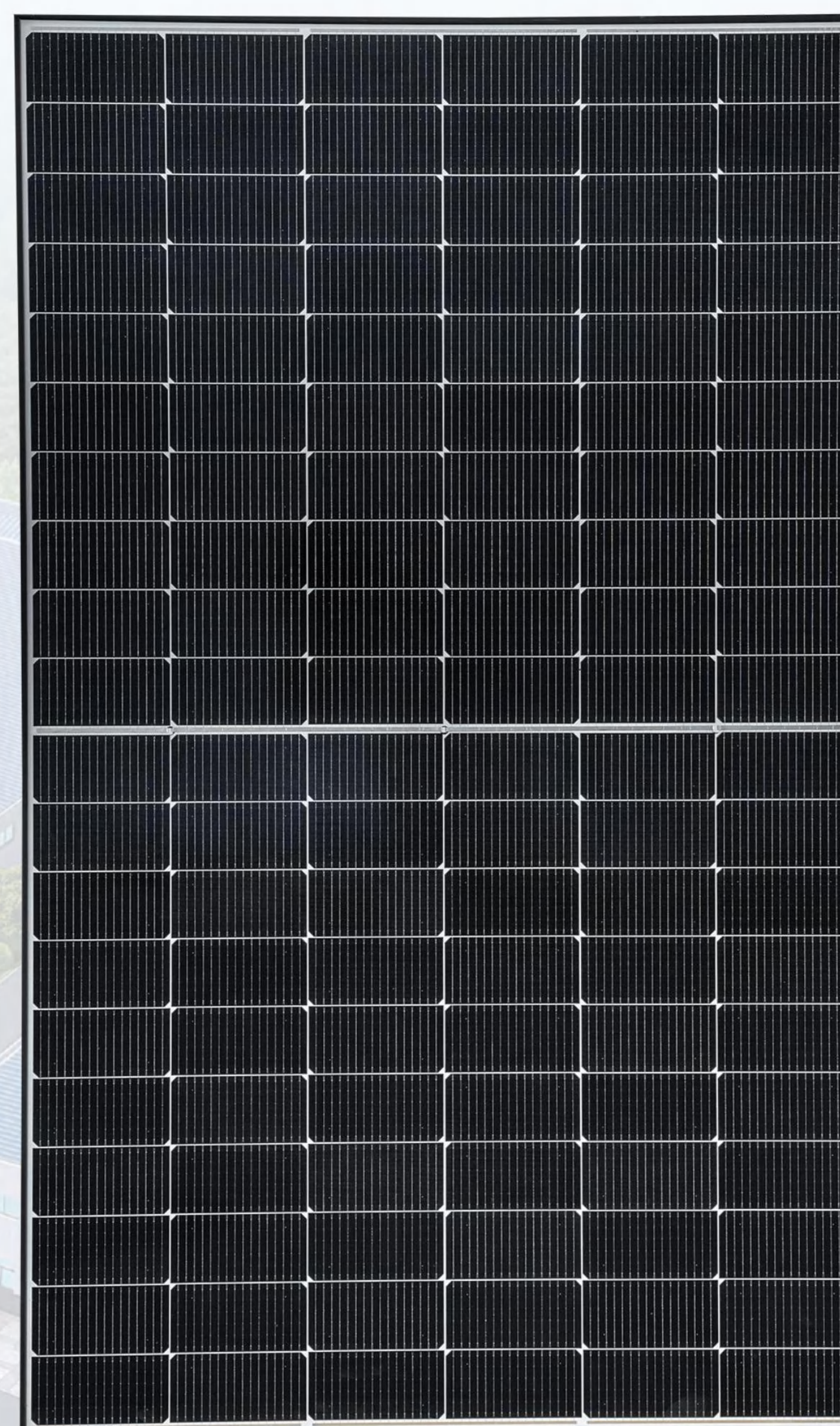

TS-M10/120G

Monocrystalline Module

465W-485W

Electrical Specification [STC*]

Maximum Power	Pmax[W]	465	470	475	480	485
Maximum Power Voltage	Vmp[W]	34.89	35.05	35.21	35.38	35.55
Maximum Power Current	Imp[A]	13.33	13.41	13.49	13.57	13.65
Open Circuit Voltage	Voc[V]	42.22	42.38	42.54	42.71	42.88
Short Circuit Current	Isc[A]	14.07	14.15	14.23	14.31	14.39
Module Efficiency	[%]	21.55	21.78	22.01	22.24	22.47
Power Output Tolerance	[W]	0~+3%				

* Irradiance 1000W/m², Module Temperature 25°C, Air Mass 1.5

Electrical Specification [NOCT*]

Maximum Power	Pmax[W]	350	353	357	361	365
Maximum Power Voltage	Vmp[W]	32.77	32.94	33.10	33.27	33.44
Maximum Power Current	Imp[A]	10.67	10.73	10.79	10.85	10.92
Open Circuit Voltage	Voc[V]	40.10	40.25	40.41	40.57	40.73
Short Circuit Current	Isc[A]	11.36	11.42	11.49	11.55	11.61

* Irradiance 800W/m², Ambient Temperature 20°C, Wind Speed 1m/s

Mechanical Data

Number of Cells	120 pieces [6×20]
Dimensions of Module L*W*H [mm]	1908×1134×30/35mm
Weight [kg]	Approx 28.4/28.7 kg
Front Side Glass	2.0, Anti-reflection coating glass
Back Side Glass	2.0, Hightransparency solar glass
Frame	Anodized aluminium
J-Box	Protection level IP68
Cable	4.0mm ² ,300mm
Number of diodes	3
Wind/Snow Load	2400 Pa/5400 pa*
Connector	MC4 compatible or MC compatible

* For more details please check the installation manual

Temperature Ratings

Nominal Operating Cell Temperature [NOCT]	44±2°C
Temperature Coefficient of Isc	+0.046%/°C
Temperature Coefficient of Voc	-0.250%/°C
Temperature Coefficient of P _{MAX}	-0.300%/°C

Temperature Ratings

Operational Temperature	-40~+85°C
Maximum System Voltage	1500V DC-[H]
Max Series Fuse Rating	25A

Packaging Configuration

Module per box	36/31 pieces
Module per 17.5 flatcar	1008/992pieces
Module per 40 container	756/744 pieces

Optional

Connector	Original MC
Cable length	1200mm
Frame	Black
Glass	Black

Module Dimension

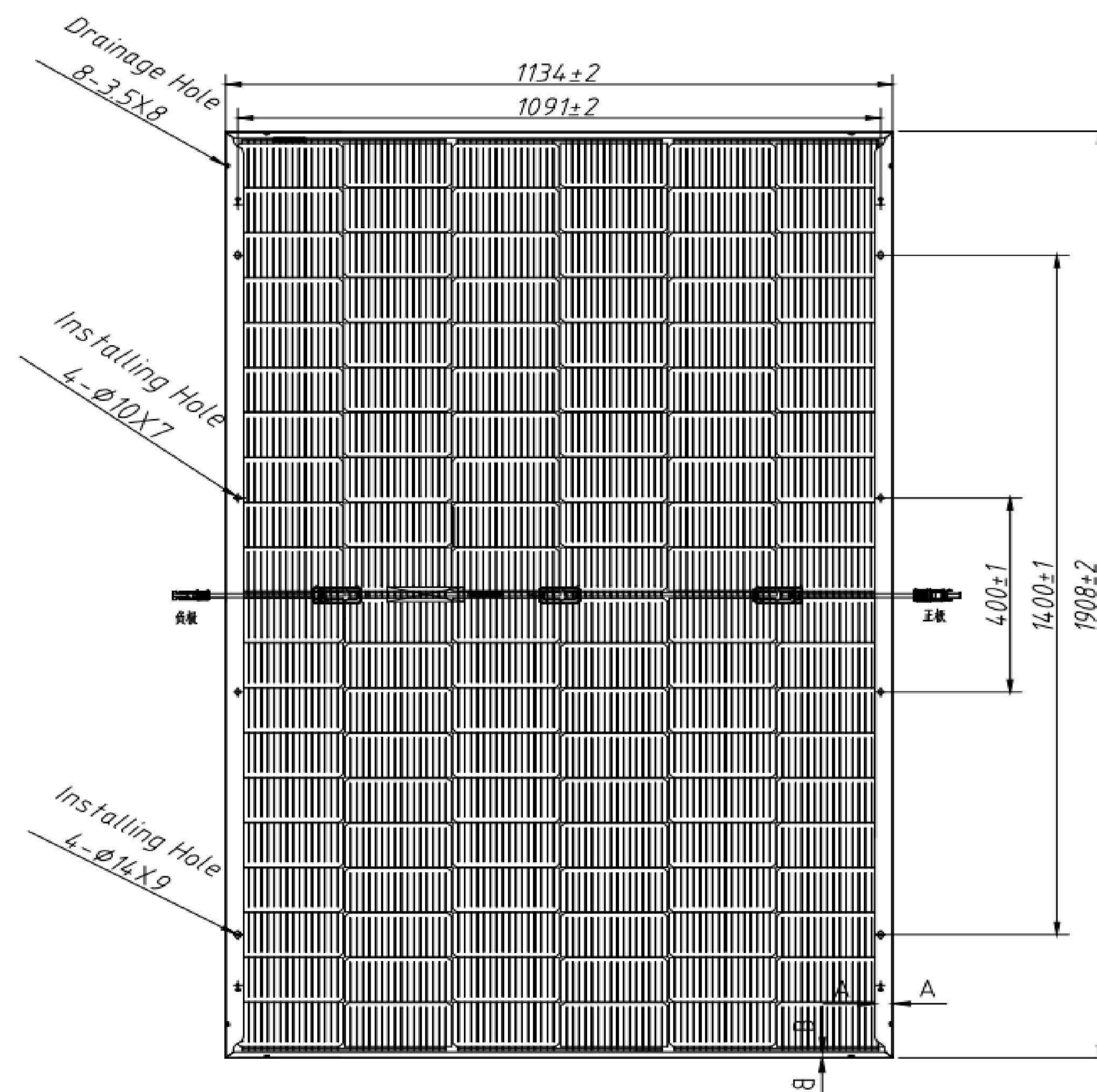

Back View

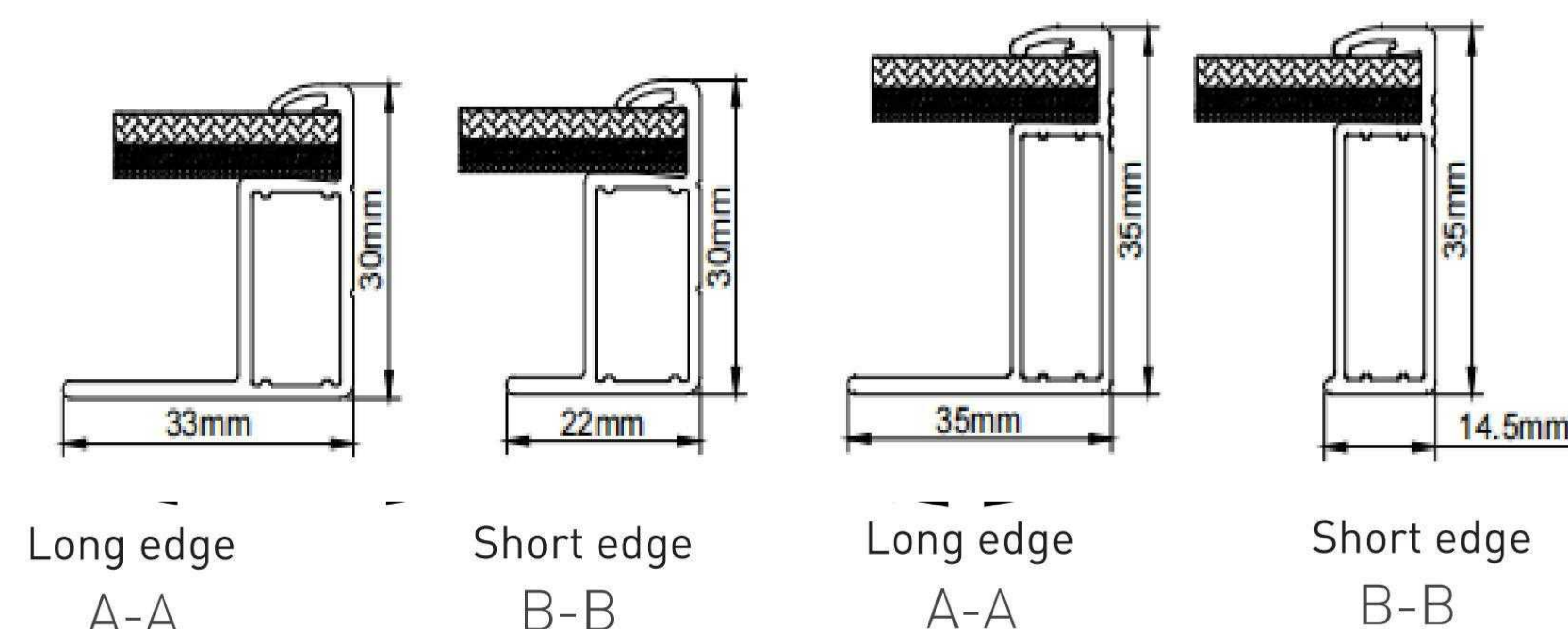

I-V Curve at Different Temperature (480W)

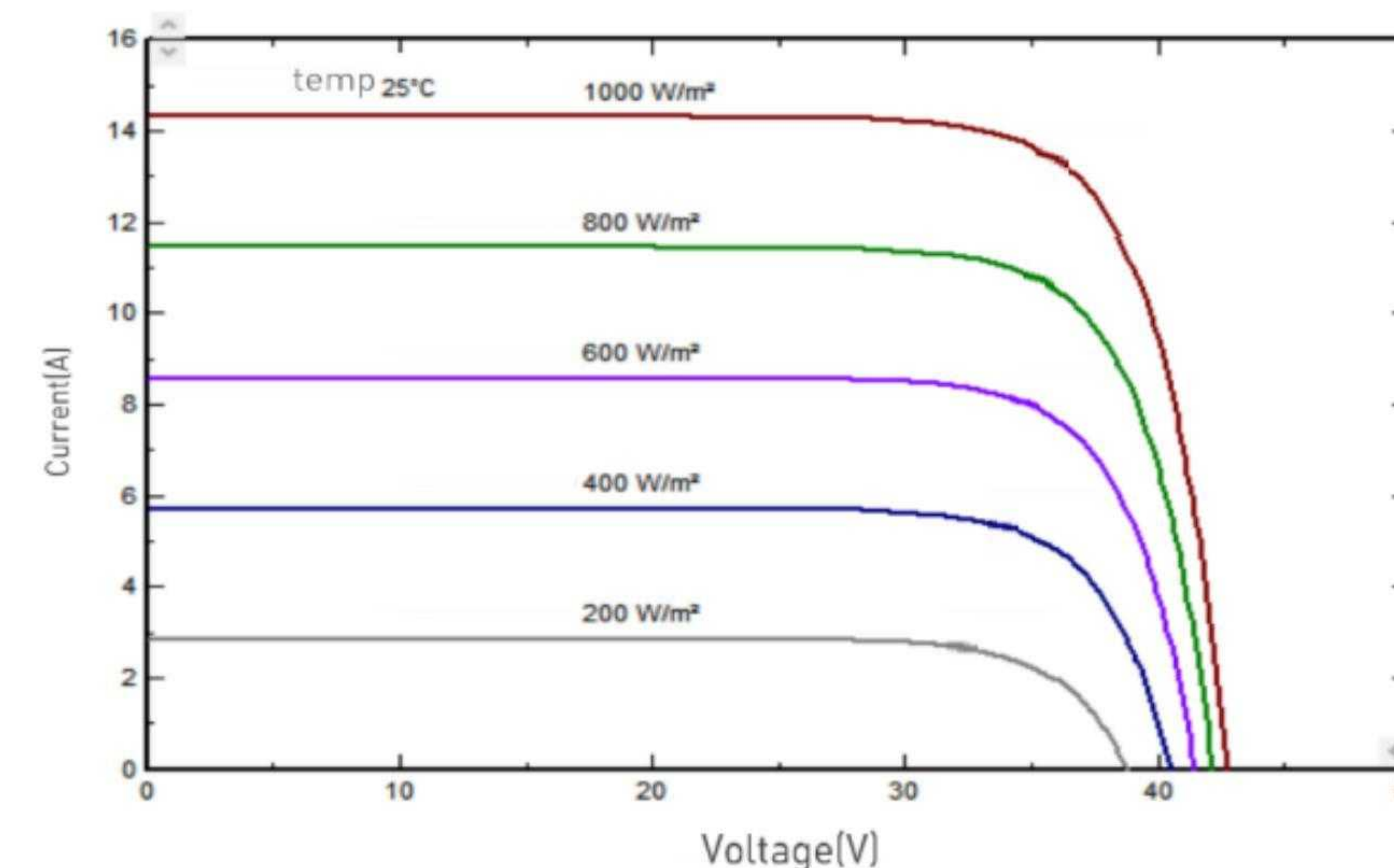

I-V/P-V Curve at Different Irradiation (480W)

