

## Solar Ocean

### 405–420 Watt MONO-FACIAL MODULE

- IEC61215: 2021
- IEC61730: 2016
- TUV Rheinland Standard
- Lloyd'S Ariel Re
- Solar Performance Insurance
- ISO9001: 2015
- Quality Management System
- ISO14001:
- Environmental Management System
- CE: Europe Standard
- Inmetro Certificate
- Japan JP-AC

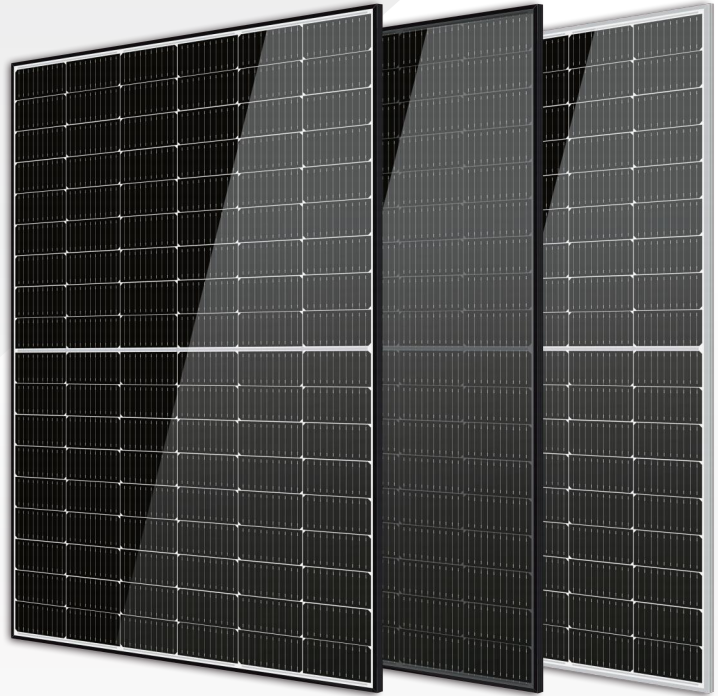

#### KEY FEATURES



**MBB Cell**  
More uniform current collection capability, reducing the current heat loss of the internal cells.



**Low Light Features**  
Higher performance under low light environment.



**Higher Output Power**  
The output power of 108 half-cells Monocrystalline modules is up to 420W.



**PID Protection**  
Ensure the attenuation probability caused by PID phenomenon is minimized.



**Harsh Environmental Adaptability**  
Strict salt spray and ammonia corrosion test by the third party.



**Load Capacity**  
Mechanical load tests including wind load 2400 Pa and snow load 5400 Pa.

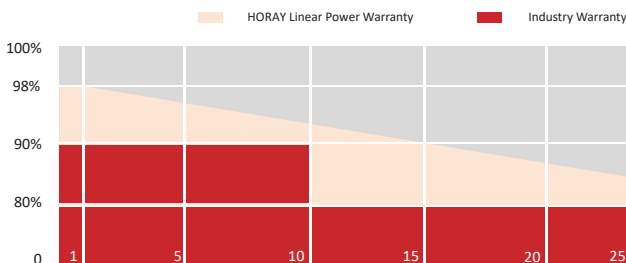

HEADQUARTER: HORAY SOLAR CO., LTD.

GLOBAL MARKETING AND SERVICE: HORAY SOLAR GMBH

✉ sales@horaysolar.com 🌐 www.horaysolar.com ☎ +86-510 83580688  
📍 NO.30-5, East Yanxin Road, Huishan District, Wuxi 214177 Jiangsu P.R China

✉ info@horaysolar.com 🌐 www.horaysolar.com  
📍 Robert-Bosch-Str. 29, Langen, Frankfurt am Main, Germany

## MECHANICAL DIAGRAMS

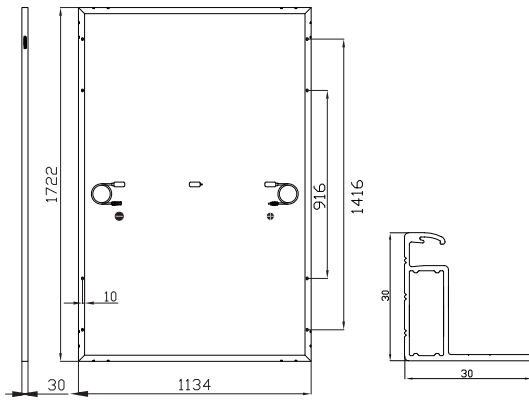

## SPECIFICATIONS

Weight	20.5kg
Dimension	1722mm*1134mm*30mm
Cell Dimension	182*91mm
Cell Amount	54*2 pcs
Maximum System Voltage	1500V
Junction Box	IP68
Frame	Aluminum Alloy
Cable	4mm <sup>2</sup> , +300,-300mm/±1100mm Length can be customized
Connector	MC4 compatible
Application Level	Class A

## ELECTRICAL PARAMETERS AT STC

Module Type	HS405-MHO	HS410-MHO	HS415-MHO	HS420-MHO
Power	405W	410W	415W	420W
Open Circuit Voltage	37.14V	37.34V	37.54V	37.74V
Short Circuit Current	13.65A	13.70A	13.77A	13.86A
Maximum Power Voltage	31.02V	31.22V	31.42V	31.62V
Maximum Power Current	13.06A	13.14A	13.21A	13.28A
Module Efficiency	20.74%	21.00%	21.25%	21.51%

\* Under Standard Test Conditions (STC) of irradiance of 1000 W/ m<sup>2</sup>, spectrum AM 1.5 and cell temperature of 25°C.

## ELECTRICAL PARAMETERS AT NMOT

Power	306W	310W	314W	318W
Open Circuit Voltage	35.15V	35.39V	35.65V	35.92V
Short Circuit Current	10.92A	10.96A	11.02A	11.09A
Maximum Power Voltage	29.29V	29.49V	29.71V	29.93V
Maximum Power Current	10.45A	10.51A	10.57A	10.62A

\* Under Nominal Module Operating Temperature (NMOT), irradiance of 800 W/ m<sup>2</sup>, spectrum AM 1.5, ambient temperature 20°C, wind speed 1 m/s.

## TEMPERATURE CHARACTERISTICS

NMOT	45±2°C	Temp Coefficient of ISC	+0.05%/°C
Temp Coefficient of VOC	-0.28%/°C	Temp Coefficient of Pmax	-0.34%/°C

## PACKING CONFIGURATION

Modules/Pallet	37 Pieces	Modules/40' Container	962 Pieces
Packaging Description	26 Pallets, Total=(37+37)x13=962 Pieces		

## IV CHARACTERISTICS

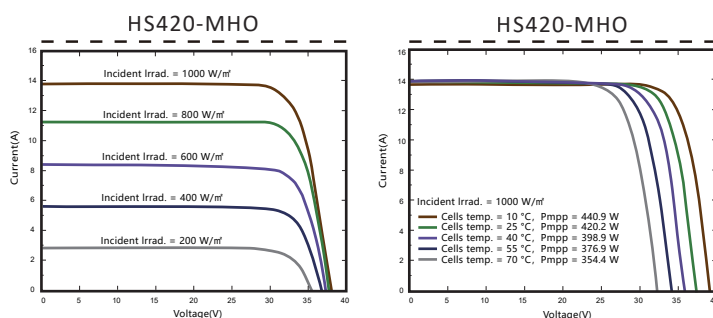

## MAXIMUM RATING

Power selection	0~+5W
Measuring uncertainty of Pm	0~±3%
Operating Temperature	-40°C~+85°C
Wind Load/Snow Load	2400pa/5400pa
Fuse Current	25A

**15 YEARS** Quality Warranty

**25 YEARS** Power Warranty

CAUTION: READ SAFETY AND INSTALLATION INSTRUCTIONS BEFORE USING THE PRODUCT.

©2024 Horay Solar Co.,Ltd. All rights reserved. Specifications included in this datasheet are subject to change without notice.

Version number: MHO\_EN\_2024\_A