

REVO HMT

Hybrid On & Off Grid Energy Storage Inverter

series 4/6/8/11kW



On-Grid and Off-Grid
REVO HMT series is suitable for on-grid and off-grid applications.



Remote Monitoring
Control and monitor your smart system on the move via our monitoring App and website



BMS
BMS Communication for lithium battery



Easy access
Accessible through a LCD touch screen and through the web. Two outputs for smart load management



Safe
Built-in anti-dust kit for harsh environment AC overcurrent, AC overvoltage, over temperature protection



Flexible Rate Tariff
Charge from the grid at off-peak time when energy is cheaper and discharge at peak time when energy is more expensive.

Product characteristics

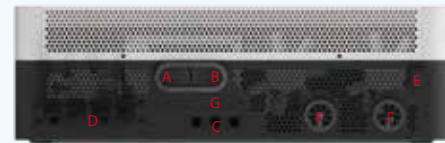

A: AC OUTPUT
B: AC INPUT
C: COM
D: PV INPUT
E: ON/OFF
F: DC INPUT
G: PARALLEL CONNECTION



LCD touch screen

Circuit block diagram

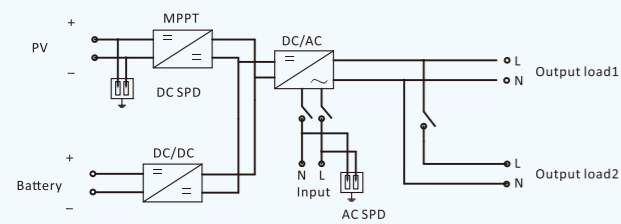

Product application diagram

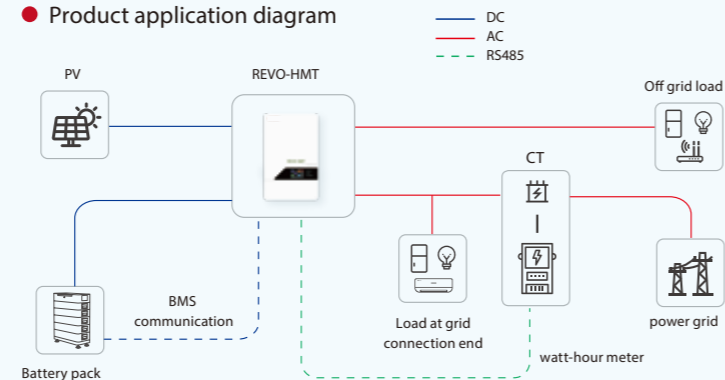

Technical Specification	REVO HMT series				
	4000VA/4000W	6000VA/6000W	6000VA/6000W	8000VA/8000W	11000VA/11000W
AC INPUT					
AC Voltage	220/230/240VAC				
Voltage Range	170-280VAC (For Personal Computers); 90-280 VAC (For Home Appliances)				
Frequency Range	50/60Hz (Auto sensing)				
AC OUTPUT					
Surge Power	8000VA	12000VA	12000VA	16000VA	22000VA
Voltage Regulation (Battery Mode)	220VAC/230VAC/240VAC ± 5%				
Rated frequency	50/60Hz				
Efficiency (Peak)	93%				
Transfer Time	10ms (For Personal Computers); 20ms (For Home Appliances)				
BATTERY					
Battery Voltage	48VDC				
Floating Charge Voltage	54VDC				
Overcharge Protection	63VDC				
Battery type	Lithium/Lead-acid				
SOLAR CHARGER & AC CHARGER					
Maximum PV Array Open Circuit Voltage	500VDC				
Maximum PV Array Power	5000W	8000W (4000*2)	11000W (5500W*2)		
MPPT voltage range(V)	90~450VDC				60~450VDC
Maximum input current	27A				27A*2 (MAX 40A)
MPPT tracker/strings	1				2
Maximum solar charge current	80A	120A	120A	150A	
Maximum AC charge current	60A	100A	120A	150A	
Maximum charge current	80A	120A	120A	150A	
PROTECTION & FEATURE					
AC overcurrent	Yes				
AC overvoltage	Yes				
Over temperature protection	Yes				
Smart load management	Yes				
On Grid	Yes				
Parallel function	Yes, 6 units				
GENERAL PARAMETERS					
Operation temperature	-10° C ~ 50° C				
Relative humidity	5% ~ 95% (Non-condensing)				
Altitude	>2000m Derating)				
Dimensions D x W x H(mm)	315*134*516	134*390*516	147.4*432.5*553.6		
Net Weight(KG)	9	10.5	16.5	18	18.4
DISPLAY AND COMMUNICATION					
Display	Touch screen				
Interface	Standard: RS232, CAN&RS485; Optional: WiFi, Bluetooth, CT				
Safety standard	EN/IEC 62109-1, EN/IEC 62109-2				