



LEAPTON
SOLAR

Monofacial

Bifacial

LP182*210-M-48-NH N-Type TOPCon

Rated Power 435-455W



N-Type 182*210mm Cell
Adopting the 182*210mm N-Type TOPCon battery cells with the highest efficiency.



Low Light Features
Higher performance under low light environment.



Higher Output Power
Module adopts 96 pcs of 182*210mm half cells, the maximum power can reach 455W.



Load Capacity
Mechanical load tests including wind load 2400 Pa and snow load 5400 Pa done by TUV Nord.



Harsh Environmental Adaptability
Strict salt spray and ammonia corrosion test by TUV Nord.



PID Protection
Ensure the attenuation probability caused by PID phenomenon is minimized.

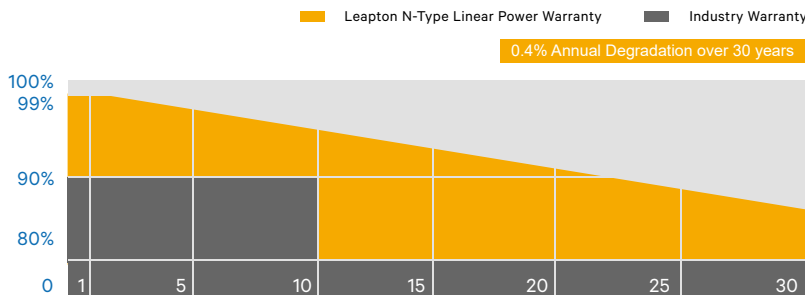

Headquarter : Leapton Energy Co., Ltd.

Tosei Bldg. 6F, 1-2-1 Aioi-cho, Chuo-ku Kobe-shi, Hyogo, 650-0025, Japan

+81-78-382-3182

www.leaptonenergy.jp

Manufacturer : Leapton Solar (Changshu) Co., Ltd.

No.9, Sunshine Avenue, Changshu City, Jiangsu, China

+86-512-88800068

info@leaptonenergy.com

www.leaptonpv.com

MECHANICAL DIAGRAMS

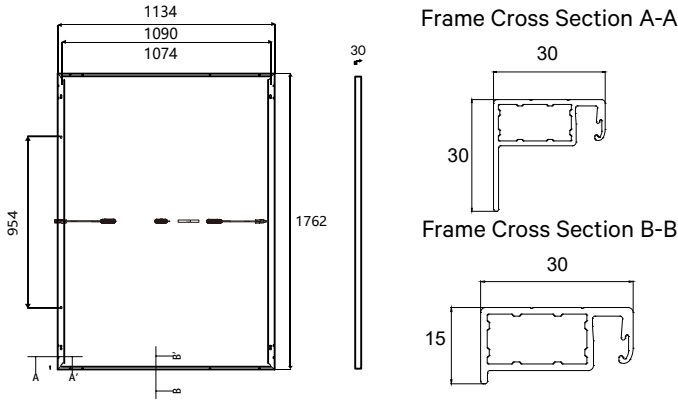

SPECIFICATIONS

Weight	22kg
Dimensions	1762mm*1134mm*30mm
Cell Dimensions	182*210mm
Cell Amount	48*2 pcs
Maximum System Voltage	1500V
Junction Box	IP68
Front glass	3.2 mm heat strengthened glass with anti-reflective coating
Frame	Aluminum Alloy
Cable	4mm ² , N 1100mm/P 1100mm for Horizontal installation 4mm ² , N 300mm/P 300mm for Vertical installation
Connector	MC4 compatible

ELECTRICAL PARAMETERS AT STC

Power	435W	440W	445W	450W	455W
Open Circuit Voltage	35.13V	35.38V	35.63V	35.88V	36.13V
Short Circuit Current	15.77A	15.84A	15.90A	15.97A	16.02A
Maximum Power Voltage	29.18V	29.38V	29.58V	29.78V	29.98V
Maximum Power Current	14.91A	14.98A	15.04A	15.11A	15.18A
Module Efficiency	21.77%	22.02%	22.27%	22.52%	22.77%

* Under Standard Test Conditions (STC) of irradiance of 1000 W/m², spectrum AM 1.5 and cell temperature of 25°C.

ELECTRICAL PARAMETERS AT NMOT

Power	331W	335W	339W	343W	347W
Open Circuit Voltage	33.30V	33.56V	33.82V	34.08V	34.34V
Short Circuit Current	12.66A	12.74A	12.79A	12.85A	12.88A
Maximum Power Voltage	27.48V	27.67V	27.86V	28.05V	28.24V
Maximum Power Current	12.05A	12.11A	12.17A	12.23A	12.29A

* Under Nominal Module Operating Temperature (NMOT), irradiance of 800 W/m², spectrum AM 1.5, ambient temperature 20°C, wind speed 1 m/s.

TEMPERATURE CHARACTERISTICS

NMOT	41±3°C	Temp Coefficient of ISC	+0.046%/°C
Temp Coefficient of VOC	-0.25%/°C	Temp Coefficient of Pmax	-0.30%/°C

PACKING CONFIGURATION

Modules/Pallet	36 Pieces	Modules/40'Container	936 Pieces
Packing Description	26 Pallets, Total=(36+36)x13=936 Pieces		

CHARACTERISTICS

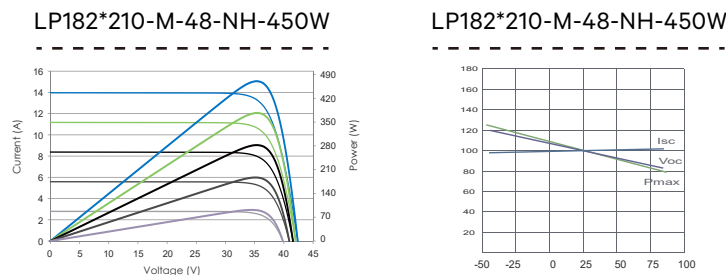

MAXIMUM RATING

Output Tolerance	0~+5W
Operating Temperature	-40°C~+85°C
Wind Load/Snow Load	2400pa/5400pa
Fuse Current	25A



Headquarter : Leapton Energy Co., Ltd.

☑ Tosei Bldg. 6F, 1-2-1 Aioi-cho, Chuo-ku Kobe-shi, Hyogo, 650-0025, Japan

☎ +81-78-382-3182

🌐 www.leaptonenergy.jp

Manufacturer : Leapton Solar (Changshu) Co., Ltd.

☑ No.9, Sunshine Avenue, Changshu City, Jiangsu, China

☎ +86-512-88800068

✉ info@leaptonenergy.com

🌐 www.leaptonpv.com