

LP182*182-M-54-NB

Rated Power 430-450W

N-Type TOPCon Dual Glass



N-Type MBB Cell
New circuit design N-type cells, can increase the output power of 10W~20W



Low Light Features
Higher performance under low light environment.



Bifacial with dual glass
Module adopts 182*188mm half cells, bifacial module provide an additional 5%~25% output.



PID Protection
Ensure the attenuation probability caused by PID phenomenon is minimized.



Harsh Environmental Adaptability
Strict salt spray and ammonia corrosion test by TUV Nord.



Load Capacity
Mechanical load tests including wind load 2400 Pa and snow load 5400 Pa done by TUV Nord.

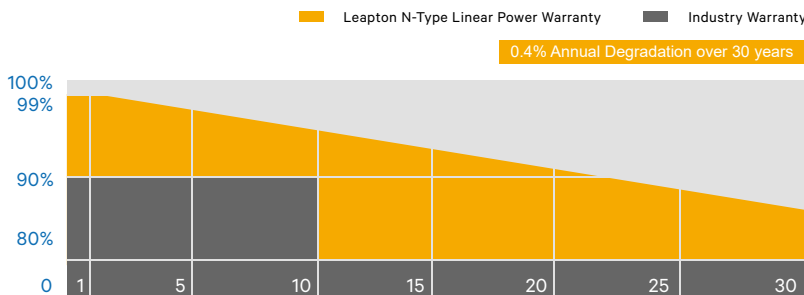

Headquarter : Leapton Energy Co., Ltd.

Tosei Bldg. 6F, 1-2-1 Aioi-cho, Chuo-ku Kobe-shi, Hyogo, 650-0025, Japan

+81-78-382-3182

www.leaptonenergy.jp

Manufacturer : Leapton Solar (Changshu) Co., Ltd.

No.9, Sunshine Avenue, Changshu City, Jiangsu, China

+86-512-88800068

info@leaptonenergy.com

www.leaptonpv.com

MECHANICAL DIAGRAMS

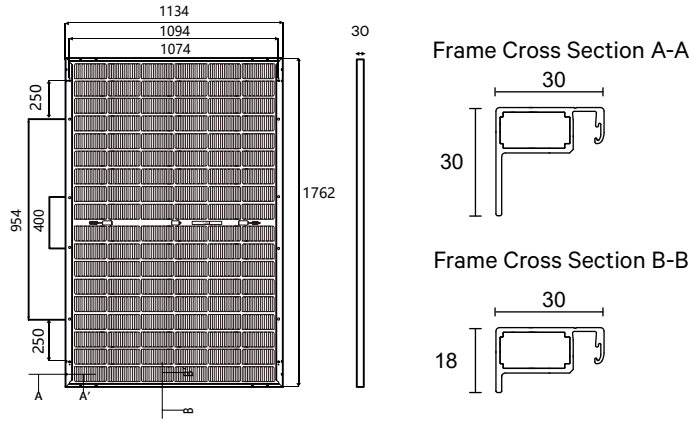

SPECIFICATIONS

Weight	25kg
Dimensions	1762mm*1134mm*30mm
Cell Dimensions	182*188mm
Cell Amount	54*2 pcs
Maximum System Voltage	1500V
Junction Box	IP68
Front glass	2.0mm, Anti-Reflection Coating
Back glass	2.0mm, Heat Strengthened Glass
Frame	Aluminum Alloy
Cable	4mm ² , N 1100mm/P 1100mm for Horizontal installation 4mm ² , N 300mm/P 300mm for Vertical installation
Connector	MC4 compatible
Bifaciality	80±5%

ELECTRICAL PARAMETERS AT STC

Power	430W	435W	440W	445W	450W
Open Circuit Voltage	39.08V	39.23V	39.38V	39.53V	39.68V
Short Circuit Current	13.80A	13.89A	13.98A	14.07A	14.15A
Maximum Power Voltage	32.26V	32.42V	32.57V	32.72V	32.87V
Maximum Power Current	13.33A	13.42A	13.51A	13.60A	13.69A
Module Efficiency	21.52%	21.77%	22.02%	22.27%	22.52%

* Under Standard Test Conditions (STC) of irradiance of 1000 W/m², spectrum AM 1.5 and cell temperature of 25°C.

ELECTRICAL PARAMETERS AT NMOT

Power	324W	327W	331W	335W	339W
Open Circuit Voltage	37.08V	37.23V	37.38V	37.53V	37.68V
Short Circuit Current	11.15A	11.17A	11.24A	11.31A	11.37A
Maximum Power Voltage	30.09V	30.23V	30.37V	30.54V	30.68V
Maximum Power Current	10.77A	10.82A	10.90A	10.97A	11.05A

* Under Nominal Module Operating Temperature (NMOT), irradiance of 800 W/m², spectrum AM 1.5, ambient temperature 20°C, wind speed 1 m/s.

ELECTRICAL PARAMETERS (AT 10% BIFACIAL POWER OUTPUT)

Output Power	473W	479W	484W	490W	495W
Open Circuit Voltage	39.08V	39.23V	39.38V	39.53V	39.68V
Short Circuit Current	15.28A	15.39A	15.47A	15.58A	15.66A
Maximum Power Voltage	32.27V	32.41V	32.57V	32.71V	32.87V
Maximum Power Current	14.66A	14.78A	14.86A	14.98A	15.06A

TEMPERATURE CHARACTERISTICS

NMOT	41±3°C	Temp Coefficient of ISC	+0.046%/°C
Temp Coefficient of VOC	-0.25%/°C	Temp Coefficient of Pmax	-0.30%/°C

PACKING CONFIGURATION

Modules/Pallet	36 Pieces	Modules/40'Container	936 Pieces
----------------	-----------	----------------------	------------

Packing Description 26 Pallets, Total=(36+36)x13=936 Pieces

CHARACTERISTICS

LP182*182-M-54-NB-450W

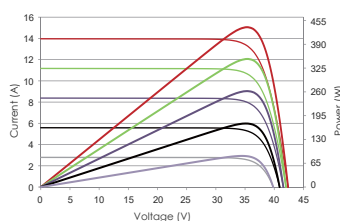

LP182*182-M-54-NB-450W

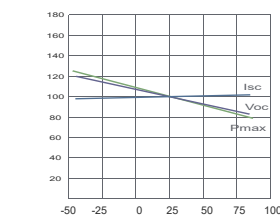

MAXIMUM RATING

Output Tolerance	0~+5W
Operating Temperature	-40°C~+85°C
Wind Load/Snow Load	2400pa/5400pa
Fuse Current	25A



Headquarter : Lepton Energy Co., Ltd.

📍 Tosei Bldg. 6F, 1-2-1 Aioi-cho, Chuo-ku Kobe-shi, Hyogo, 650-0025, Japan

☎ +81-78-382-3182

🌐 www.leptonenergy.jp

Manufacturer : Lepton Solar (Changshu) Co., Ltd.

📍 No.9, Sunshine Avenue, Changshu City, Jiangsu, China

☎ +86-512-88800068

✉ info@leptonenergy.com

🌐 www.leptonpv.com