

Product Model

POW-LTW-15A



POWMr

SOLAR CHARGE CONTROLLER

User Manual

Important Safety Guidelines

Warning: Please carefully read and adhere to all safety instructions.

- Before installing and operating the controller, carefully read the user manual and keep it stored safely for future reference.
- Installation or operation of the controller is not permitted for the following individuals without strict guidance and supervision:
 - a. Anyone lacking the relevant knowledge, experience, or capability for safe installation and/or operation requirements.
 - b. Anyone with impaired or diminished physical, sensory, or intellectual capabilities that may affect safe installation and/or operation (including children).

Controller Installation and Operation

- a. This controller product has no user-serviceable parts. Do not dismantle or attempt to repair the controller.
- b. Install the controller in an environment with good natural ventilation and ensure sufficient spacing around it.
- c. Mount the controller on a non-flammable wall and ensure there are no flammable materials nearby; temperature elevation during controller operation is normal.
- d. Install the controller in an environment free from direct sunlight, rainwater, humidity, and dust, and keep it away from any flammable liquids or gases. The controller is for indoor use only.
- e. Do not install or place/operate the controller on top of or directly above batteries or in enclosed spaces containing batteries, as batteries release explosive gases.
- f. Do not place any other items on top of the controller.

Battery Installation and Charging

- a. Install and charge batteries in a well-ventilated or exhaust environment.
- b. Ensure there are no sources of ignition around the batteries, as they release explosive gases.
- c. Battery acid is corrosive; if battery acid comes into contact with the skin, immediately rinse with clean water.
- d. Do not charge non-rechargeable batteries. Do not charge lithium batteries when the temperature is below 0°C. Charging frozen batteries is prohibited.

- e. Ensure the equipment is set up reasonably according to the connected battery type.

DC Battery Wiring

- a. Ensure all cables and/or new ports connecting to the battery/DC system are fully closed/disconnected in advance.
- b. Use flexible multi-strand copper cables with appropriate cross-sectional areas and connect them to matching fuses or circuit breakers.
- c. It is prohibited to connect the solar array to the controller without the battery connected; priority must be given to connecting the battery.

Controller Settings

- a. Refer to the battery manufacturer's guide and specifications to ensure the batteries are suitable for the controller and confirm the recommended charging settings.
- b. Integrated charging modes include adaptive charging logic, which is suitable for most battery types.

Disclaimer

In any of the following circumstances, our company reserves the right to disclaim liability for quality assurance:

- Damage caused by improper transportation.
- Damage resulting from incorrect storage, installation, or usage.
- Damage caused by non-professionals or untrained personnel installing and using the equipment.
- Damage resulting from failure to adhere to the instructions and safety warnings in this document.
- Damage caused by operation in environments not meeting the requirements specified in this document.
- Damage resulting from operation beyond the parameters specified in the applicable technical specifications.
- Damage caused by unauthorized dismantling, alteration of the product, or modification of software code.
- Damage caused by exceptional natural circumstances (force majeure), such as lightning, earthquakes, fires, storms, etc.
- Any damage resulting from failure to follow local standards and regulations during installation and operation processes.
- Products beyond the warranty period.

Table of Contents

Important Safety Guidelines	1
1 Product Introduction	4
1.1 Features	5
1.2 Product Appearance	7
2 Installation and Wiring	8
2.1 Unboxing and Inspection	8
2.2 Selecting Installation Location	8
2.3 Wiring Precautions	9
2.4 Wiring Guidelines	9
3 Operation Guide	11
3.1 Button Introduction	11
3.2 Interface Icon Explanation	12
3.3 Display Page Overview	13
3.4 Setting Guide	14
3.5 Default Charging Parameters for Different Battery Types	16
4 Protection	18
4.1 Protection Functions	18
4.2 Troubleshooting	19
5 Maintenance	20
6 Specifications	21

1 Product Introduction

Welcome to choose the POW-LTW-15A Solar Controller. This controller continues PowMr's relentless pursuit of innovation in solar technology, designed specifically for small-scale solar system applications. The controller utilizes advanced CNC technology, equipped with an LCD display screen, and automated operation features. Incorporating MPPT charging algorithm and advanced control technology, it aims to extend the lifespan of energy storage system batteries.

The POW-LTW-15A Solar Controller automatically controls the charging and discharging process through precise algorithms, gradually adjusting the charging voltage to optimize the battery's charging and discharging process, thereby enhancing battery lifespan and overall system performance. Additionally, the controller is equipped with self-diagnostic and electronic protection functions, effectively preventing potential damage to the controller and batteries during installation errors or system malfunctions, ensuring system reliability and stability.

Featuring a compact structure and precise internal components, the POW-LTW-15A offers outstanding and reliable performance, balancing volume, weight, and performance. Its plug-and-play wiring design allows users to enjoy a simple and convenient application experience.

To meet various energy storage system and solar application requirements, we have built a user-friendly customizable open program configuration interface, accelerating the configuration process of solar energy systems, while providing more possibilities for system expansion. The independent battery type configuration button supports users in quickly completing configurations with a single button operation.

By choosing the POW-LTW-15A Solar Controller, you will gain an efficient, sustainable, and secure energy management solution, providing solid support for future energy needs. We are committed to driving the development of solar technology, and delivering exceptional products and services to you.

1.1 Features

- **Compact Size, Lightweight**

The controller features a compact internal structure design and precise internal components, reducing the overall size and weight, enhancing its flexibility for various scenarios.

- **Integrated Charging Presets**

Integrated charging modes, including adaptive charging logic, are highly suitable for most battery types, such as flooded lead-acid batteries, gel sealed lead-acid batteries, and lithium batteries. Specific battery type charging parameters are detailed in Section 3.5.

- **Flexible Application**

Compatible with 12V/24V system voltage.

- **Plug-and-Play Wiring**

The design of plug-and-play wiring ports speeds up the wiring process, saving users approximately 65% of wiring time. Additionally, dedicated cable connectors help mitigate the risk of reverse connections.

- **"One-Key" Battery Type Configuration**

A dedicated button allows for quick configuration of battery types. Once configured with a single press, the controller immediately starts charging the battery.

- **Multi-Stage Charging Algorithm**

Specifically designed to optimize each charging cycle, the multi-stage charging algorithm maintains battery capacity by presetting charging parameters for specific charging stages after the battery is fully charged.

- **Maximum Power Point Tracking (MPPT) Technology**

MPPT technology tracks the maximum power point voltage (V_{mp}) of the array as weather conditions change throughout the day, ensuring maximum power collection from the array.

- **Efficient Charging**

Innovative MPPT technology achieves tracking efficiency of up to 99.9% and peak conversion efficiency of up to 97%, reducing power consumption, minimizing heat generation, and lowering operating temperatures.

- **Adaptive Boost Charging**

During initial charging, adaptive boost charging monitors battery response and automatically determines the duration of the boost stage that corresponds to each independent charging cycle. This ensures the battery is fully charged at any discharge level or capacity, avoiding timeouts during the boost charging stage (extends battery life).

- **Durable and Safe**

The controller features multiple protections, including:

- a. Photovoltaic array short circuit protection
- b. Photovoltaic input overcurrent protection
- c. Photovoltaic polarity reverse connection protection
- d. Battery polarity reverse connection protection
- e. Over-temperature protection

- **Silent Operation**

Designed with an aluminum alloy heat dissipation back panel to optimize heat dissipation efficiency, the controller achieves near-silent operation.

- **Lithium Battery Activation**

Compatible with lithium batteries, the charging cycle adapts accordingly when battery type parameters are set to lithium batteries. Additionally, when connected lithium batteries are in a protected state, the controller activates the lithium batteries with current from the solar panel within the lithium battery's protection voltage and current range.

Warning: Do not charge lithium batteries when the temperature is below 0°C.

1.2 Product Appearance

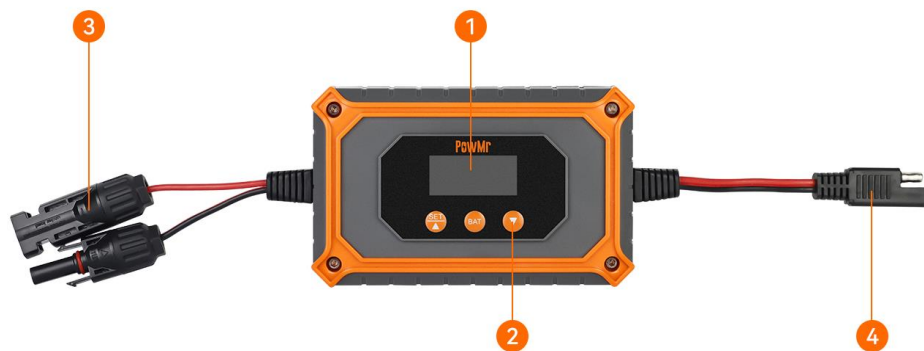

1	LCD Display Screen	3	Photovoltaic Input Interface
2	Function Buttons	4	Battery Interface

2 Installation and Wiring

2.1 Unboxing and Inspection

Before unboxing, check if the packaging is damaged. After unboxing, inspect the contents for any damage or missing items. Inside the package, you will find:

- Controller
- User Manual
- SAE cables

2.2 Selecting Installation Location

Before installation, consider the following aspects to determine/provide a suitable and safe installation location:



Install the controller in a space with good natural ventilation/exhaust.



Avoid direct sunlight.



Ensure there is sufficient clearance around the controller. The minimum clearance for the top, bottom, and sides of the controller is 75mm.



Mount the controller on a non-flammable wall and ensure there are no flammable materials nearby; temperature elevation during controller operation is normal.



Install the controller in an environment free from direct sunlight, rainwater, humidity, and dust, and keep it away from any flammable liquids or gases. The controller is for indoor use only.

*Please refer to the following steps to complete the installation and wiring of the controller. Alternatively, scan the QR code on the right to access the operating guide.



2.3 Wiring Precautions

1. Follow the sequence below for wiring: Battery > Photovoltaic Input.
2. Loose connections can cause cables or terminals to overheat, so ensure all cables are tightened to limit transition resistance as much as possible. Use cables of appropriate size according to the current rating of the specific circuit.

2.4 Wiring Guidelines

Follow the steps below to complete the controller wiring. Alternatively, scan the QR code on the right for the operation guide.

- Step 1. Connect one end of the SAE cable to the battery. If the cable length is insufficient, use an extension cable, and strictly differentiate between positive and negative terminals.



- Step 2. Connect the SAE connector on the battery end to allow the controller to access the battery power supply. Before connecting to the battery, ensure correct polarity of the cable connections.

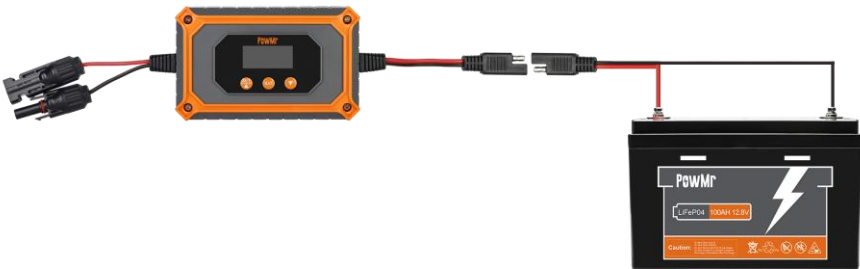

Step 3. Connect the photovoltaic array. Connect the photovoltaic array to the controller's built-in MC4 connector to access the photovoltaic input power.



NOTE

- Follow the wiring sequence: Battery > Photovoltaic Input. Incorrect wiring sequence may cause irreversible damage to the controller.
- Connect positive cable terminals to positive ports and negative cable terminals to negative ports.

3 Operation Guide

3.1 Button Introduction

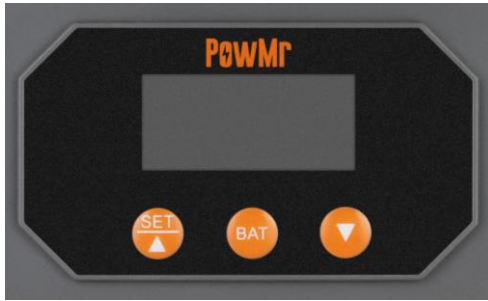

Button		Function	
SET/▲	Browse Mode	Short Press	Enter the next page.
		Long Press	Enter settings.
	Setting Mode	Short Press	Navigate to the next option/increase value.
		Long Press	Confirm the option.
BAT	Short Press	Enter battery type settings/confirm and save battery type.	
	Long Press	Navigate to the next battery type option.	
▼	Return to the previous page/previous option/decrease value.		

3.2 Interface Icon Explanation

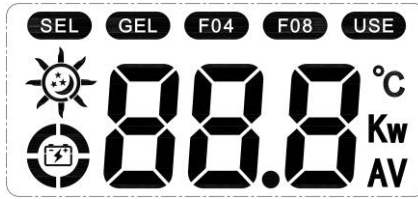

Icon	Description
	Sealed Lead-Acid Battery
	Gel Sealed Lead-Acid Battery
	4-Cell Lithium Iron Phosphate Battery
	8-Cell Lithium Iron Phosphate Battery
	Custom Battery Type
	Current Photovoltaic Input Present
	No Current Photovoltaic Input Detected
	Battery Level
	<ol style="list-style-type: none"> Sequentially displays: current battery voltage, charging current, photovoltaic input power, device temperature, calibration voltage, system voltage, boost charging voltage, float charging voltage, MPP tracking return voltage. When a device fault occurs, the fault code will be displayed, see Section 4.2 for details.

3.3 Display Page Overview

Use the ▲ or ▼ buttons to toggle through the display screens. The contents of each screen are as follows:

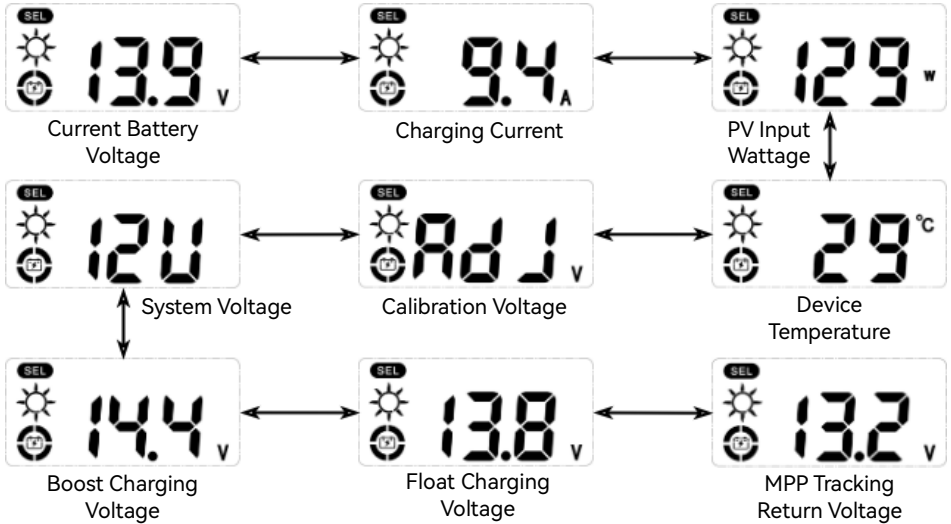

3.4 Setting Guide

Battery Type Setting

SEL

GEL

F04

F08

USE

Icon	Battery Type
SEL	Sealed Lead-Acid Battery
GEL	Gel Sealed Lead-Acid Battery
F04	4-Cell Lithium Iron Phosphate Battery
F08	8-Cell Lithium Iron Phosphate Battery
USE	User Defined

1. After completing the connection and successfully starting the controller, long-press the BATT button to enter the battery type setting interface.
2. Then, short-press the BATT button to toggle through the battery types.
3. After selecting the connected battery type, long-press the BATT button to confirm and save the battery type setting.
 - If SEL, GEL, F04, or F08 is selected, the controller will automatically detect the system voltage and use default charging parameters for battery charging, eliminating the need for manual configuration (refer to Section 3.5 for charging parameters for each battery type).
 - If USE is selected, you can set four parameters: system voltage, boost charging voltage, float charging voltage, and MPPT tracking return voltage.

* Charging Parameter Setting - Button Operation Guide:

1. Use the ▲ or ▼ keys to navigate the interface, then long-press the SET button to enter.
2. Use the ▲ or ▼ keys to increase or decrease voltage values. Press SET to confirm and save the settings.

System Voltage Setting Interface

System voltage options: 12V/24V.

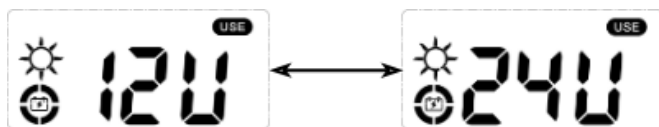

Boost Charging Voltage Setting Interface

Default: 14.4V, setting range: 9.0~17.0V, step: 0.1V.



Float Charging Voltage Setting Interface

Default: 13.8V, setting range: 9.0~17.0V, step: 0.1V.



Float Charging Voltage Setting Interface

Default: 13.2V, setting range: 9.0~17.0V, step: 0.1V.



Calibration Voltage Setting

When there is a discrepancy between the battery voltage monitored by the controller and the value measured by a multimeter, you can use this setting to calibrate the battery voltage.



3.5 Default Charging Parameters for Different Battery Types

Battery Type \ Parameters	SEL	GEL	F04	F08	USE
Boost Charging Voltage	14.4V	14.2V	14.4V	28.8V	9.0~17.0V
Float Charging Voltage	13.8V	13.8V	14.0V	28.0V	9.0~17.0V
MPP Tracking Return Voltage	13.2V	13.2V	13.2V	26.4V	9.0~17.0V

NOTE

- The charging parameters for lead-acid batteries and user-defined battery types in the table above are for 12V system voltage. For 24V system voltage, multiply these values by 2. Similarly, when connecting lead-acid batteries or user-defined battery types with a system voltage of 24V, the actual charging voltage will be twice the displayed voltage value.

● Lead-Acid Battery Charging Three Stages:

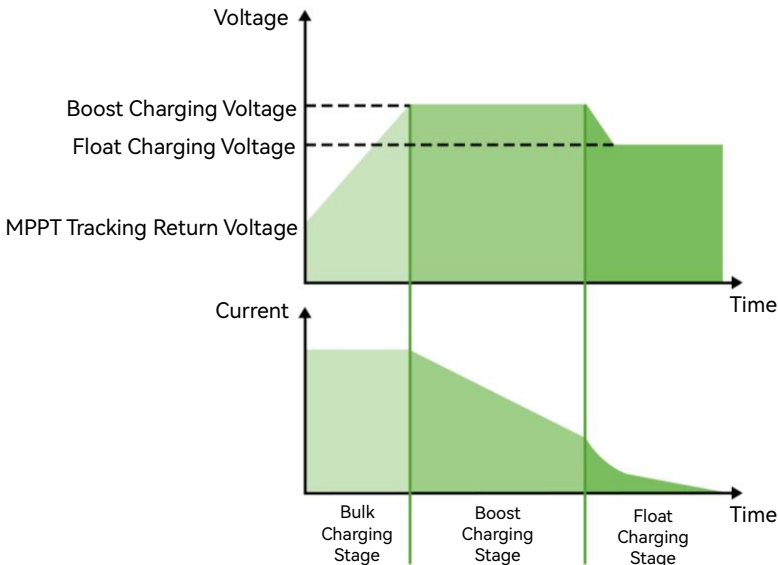

- **Lithium Battery Charging Two Stages:**

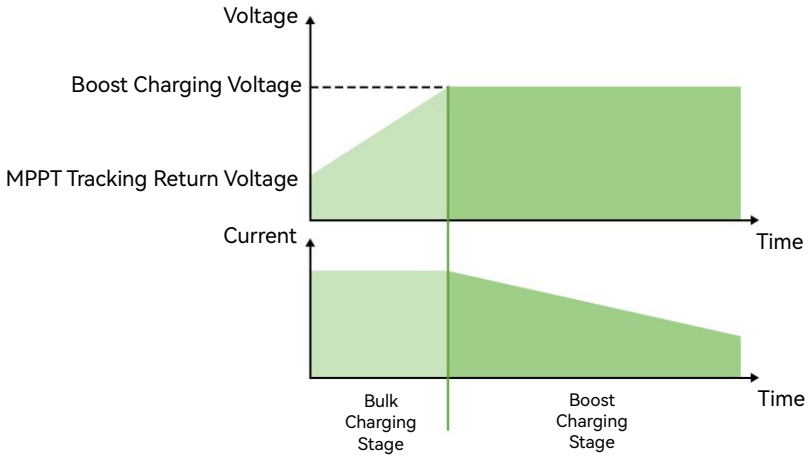

4 Protection

4.1 Protection Functions

Protection	Description
Photovoltaic Array Short Circuit	When a short circuit occurs in the photovoltaic array, the controller will cease charging. Once the short circuit fault is rectified, normal operation can resume.
Photovoltaic Input Overcurrent	The controller limits the battery charging current to the maximum rated battery current. Therefore, overcurrent from the photovoltaic array will prevent it from operating at peak power.
Photovoltaic Polarity Reversal	If the polarity of the photovoltaic wiring is reversed, the controller will not operate. Correcting the connection will restore normal controller operation.
Battery Polarity Reversal	If the polarity of the battery wiring is reversed, the controller will not operate. Correcting the connection will restore normal controller operation.
Overtemperature	When the temperature of the controller's heatsink exceeds 59.5°C, the controller will automatically begin reducing the charging current. If the temperature exceeds 80°C, the controller will automatically shut down.

4.2 Troubleshooting



Fault Code Display Example - E71

Fault Codes	Description	Explanation/Resolution
E60	Overtemperature Protection	When the temperature exceeds 85°C, the device triggers an alarm and stops charging. Once the temperature drops below 75°C, the alarm is cleared, and charging resumes.
E63	Battery Voltage Too High	Charging is automatically stopped, and charging resumes once the battery voltage returns to a normal level.
E71	Photovoltaic Input Voltage Too High	<ol style="list-style-type: none"> 1. For 12V systems, an alarm is triggered if the photovoltaic input voltage exceeds 30V. 2. For 24V systems, an alarm is triggered if the photovoltaic input voltage exceeds 60V. 3. Resolution: Change the series and parallel connection method or reduce the number of solar panels to lower the photovoltaic array voltage.
E73	Charging Current Too High	Reduce the photovoltaic input power by reducing the number of solar panels.

5 Maintenance

It is recommended to perform the following checks and maintenance tasks at least twice a year to ensure optimal operation:

1. Ensure the controller is securely installed in a clean and dry environment.
2. Ensure proper airflow around the controller and clean any dust or debris from the heat sink.
3. Inspect all exposed wires for insulation damage due to sunlight, friction, dryness, insect, or rodent damage. Repair or replace any damaged wires if necessary.
4. Tighten all terminals and check for any loose, broken, or burnt cable connections.
5. Confirm that all components of the system are properly grounded.
6. Ensure all terminals are free from corrosion, insulation damage, high temperature, or signs of burning/discoloration, and tighten terminal screws.
7. Check for dirt, nesting insects, and corrosion. Clean if necessary.

Warning: Risk of electric shock!

Before performing the above operations, ensure all power sources are switched off, then follow the relevant check and operation points.

6 Specifications

Model	POW-LTW-15A
Photovoltaic Input Parameters	
Max. Open Circuit Voltage of PV Array	
12V System	30V
24V System	60V
Maximum Input Power:	
12V System	180W
24V System	360W
Input Voltage Range:	
12V System	<30V
24V System	<60V
Battery Charging Parameters	
Charging Technology	MPPT
Charging Algorithm	3 Stages
Nominal System Voltage	12V/24V
Rated Charging Current	15A
Conversion Efficiency	≤98%
Max. Power Point Tracking Efficiency	>99%
Self-Consumption	12V20mA, 24V25mA
Environmental Parameters	
Operating Temperature Range	-35°C~+75°C
Humidity Range	≤95% Non-condensing
Altitude	<3000m
General Parameters	
Protection Level	IP32
Dimensions (excluding built-in wiring)	129x78x30mm
Net Weight	237g



POWMr

SHENZHEN HEHEJIN INDUSTRIAL CO.,LTD

Tel/Fax: +86 755-28219903

Email: support@powmr.com

Web: www.powmr.com

Add: Henggang Street, Longgang District, Shenzhen, Guangdong, China