

POW-48140A

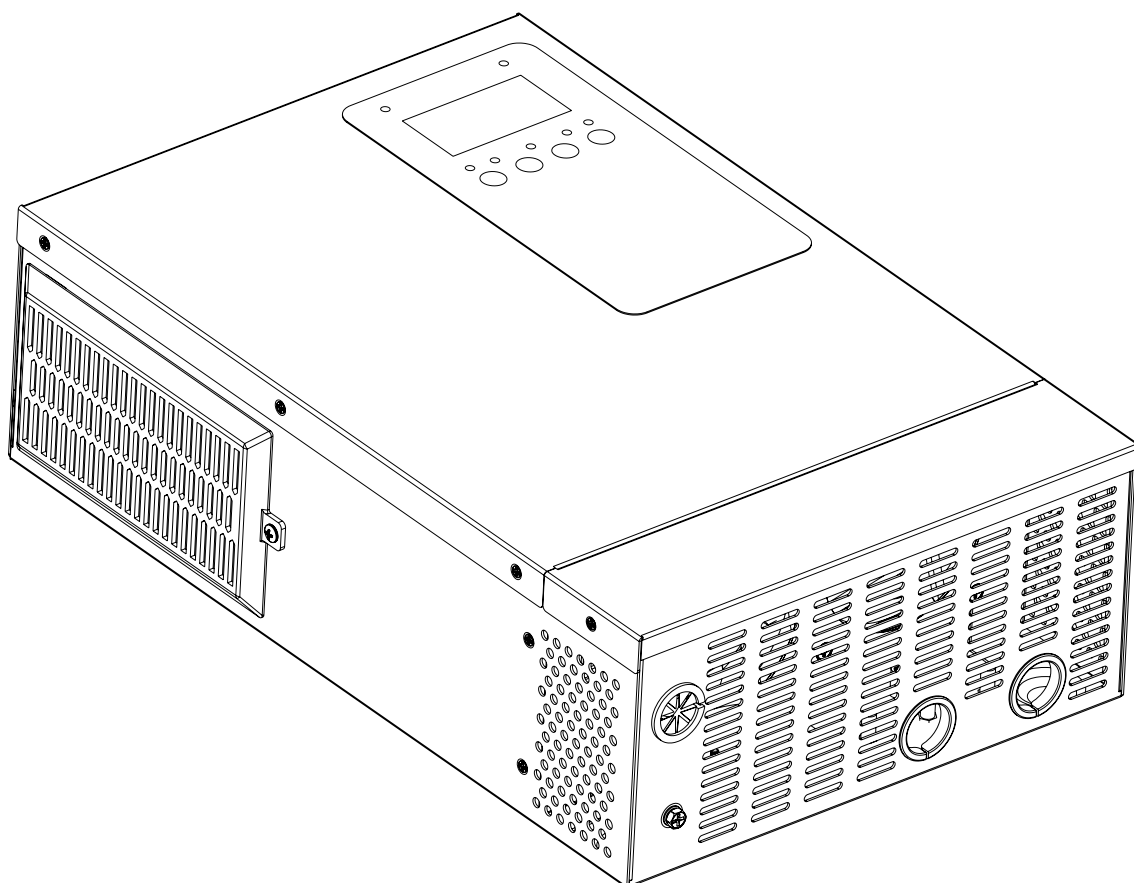

**POWMr**

**SOLAR CHARGE CONTROLLER**

User Manual

# Table Of Contents

<b>1.</b>	<b>ABOUT THIS MANUAL.....</b>	<b>2</b>
1.1	PURPOSE.....	2
1.2	SCOPE .....	2
<b>2.</b>	<b>SAFETY INSTRUCTIONS .....</b>	<b>2</b>
<b>3.</b>	<b>INTRODUCTION.....</b>	<b>3</b>
3.1	FEATURES .....	3
3.2	BASIC SYSTEM ARCHITECTURE .....	3
3.3	PRODUCT OVERVIEW.....	4
<b>4.</b>	<b>INSTALLATION .....</b>	<b>5</b>
4.1	UNPACKING AND INSPECTION .....	5
4.2	PREPARATION .....	5
4.3	MOUNTING THE UNIT .....	5
4.4	BATTERY CONNECTION .....	5
4.5	PV CONNECTION.....	7
4.6	FINAL ASSEMBLY .....	8
<b>5.</b>	<b>OPERATION.....</b>	<b>9</b>
5.1	OPERATION AND DISPLAY PANEL.....	9
5.2	LCD SETTING .....	10
5.3	DISPLAY.....	13
5.4	BATTERY EQUALIZATION DESCRIPTION .....	15
5.5	FAULT REFERENCE CODE.....	16
5.6	WARNING INDICATOR .....	16
<b>6.</b>	<b>CLEARANCE AND MAINTENANCE FOR ANTL-DUST KIT.....</b>	<b>17</b>
6.1	OVERVIEW .....	17
6.2	CLEARANCE AND MAINTENANCE.....	17
<b>7.</b>	<b>CHARGE MODE SPECIFICATIONS.....</b>	<b>18</b>
<b>8.</b>	<b>TROUBLE SHOOTING.....</b>	<b>18</b>

# 1 ABOUT THIS MANUAL

## 1.1 Purpose

This manual describes the assembly, installation, operation and troubleshooting of this unit. Please read this manual carefully before installations and operations. Keep this manual for future reference.

## 1.2 Scope

This manual provides safety and installation guidelines as well as information on tools and wiring.

# 2 SAFETY INSTRUCTIONS



**WARNING: This chapter contains important safety and operating instructions. Read and keep this manual for future reference.**

1. Before using the unit, read all instructions and cautionary markings on the unit, the batteries and all appropriate sections of this manual.
2. **CAUTION** --To reduce risk of injury, charge only deep-cycle lead acid type rechargeable batteries. Other types of batteries may burst, causing personal injury and damage.
3. Do not disassemble the unit. Take it to a qualified service center when service or repair is required. Incorrect re-assembly may result in a risk of electric shock or fire.
4. To reduce risk of electric shock, disconnect all wirings before attempting any maintenance or cleaning. Turning off the unit will not reduce this risk.
5. **CAUTION** – Only qualified personnel can install this device with battery.
6. **NEVER** charge a frozen battery.
7. For optimum operation of this charger, please follow required spec to select appropriate cable size. It's very important to correctly operate this charger.
8. Be very cautious when working with metal tools on or around batteries. A potential risk exists to drop a tool to spark or short circuit batteries or other electrical parts and could cause an explosion.
9. Please strictly follow installation procedure when you want to disconnect DC terminals. Please refer to INSTALLATION section of this manual for the details.
10. One piece of 150A fuse is provided as over-current protection for the battery supply.
11. **NEVER** cause DC input short circuited.
12. **Warning!!** Only qualified service persons are able to service this device. If errors still persist after following troubleshooting table, please send this charger back to local dealer or service center for maintenance.

### 3 INTRODUCTION

This is a solar charger. Its comprehensive LCD display offers user-configurable and easy-accessible button operation such as battery charging current.

#### 3.1 Features

- ☒ Configurable battery charging current based on applications via LCD setting
- ☒ Over temperature protection
- ☒ Smart battery charger design for optimized battery performance
- ☒ Cold start function

#### 3.2 Basic System Architecture

The following illustration shows basic application for this solar charger.

- ☒ PV modules

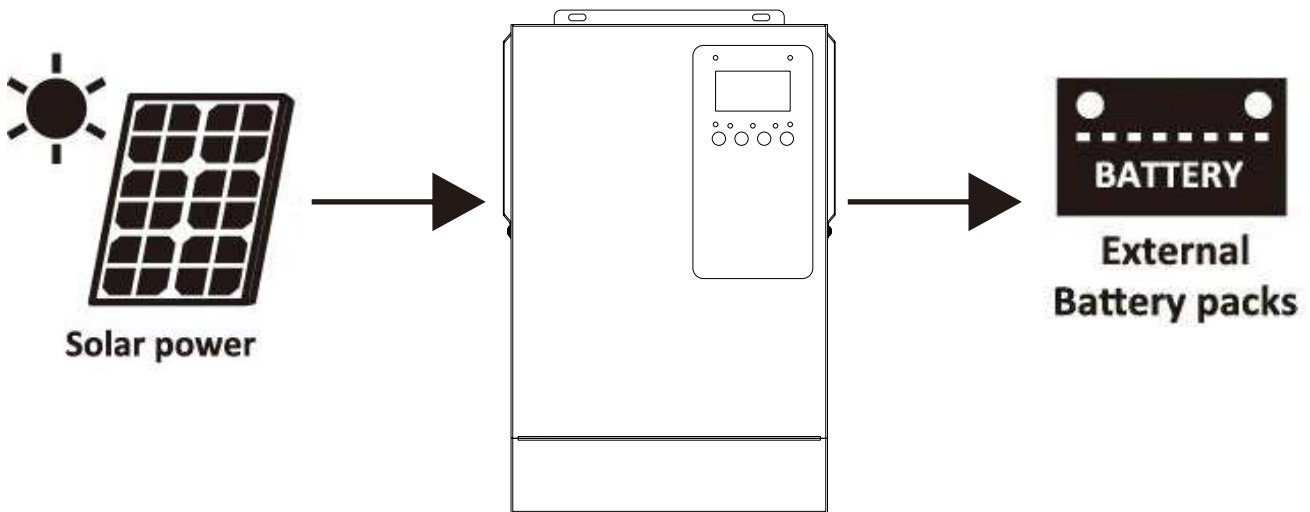
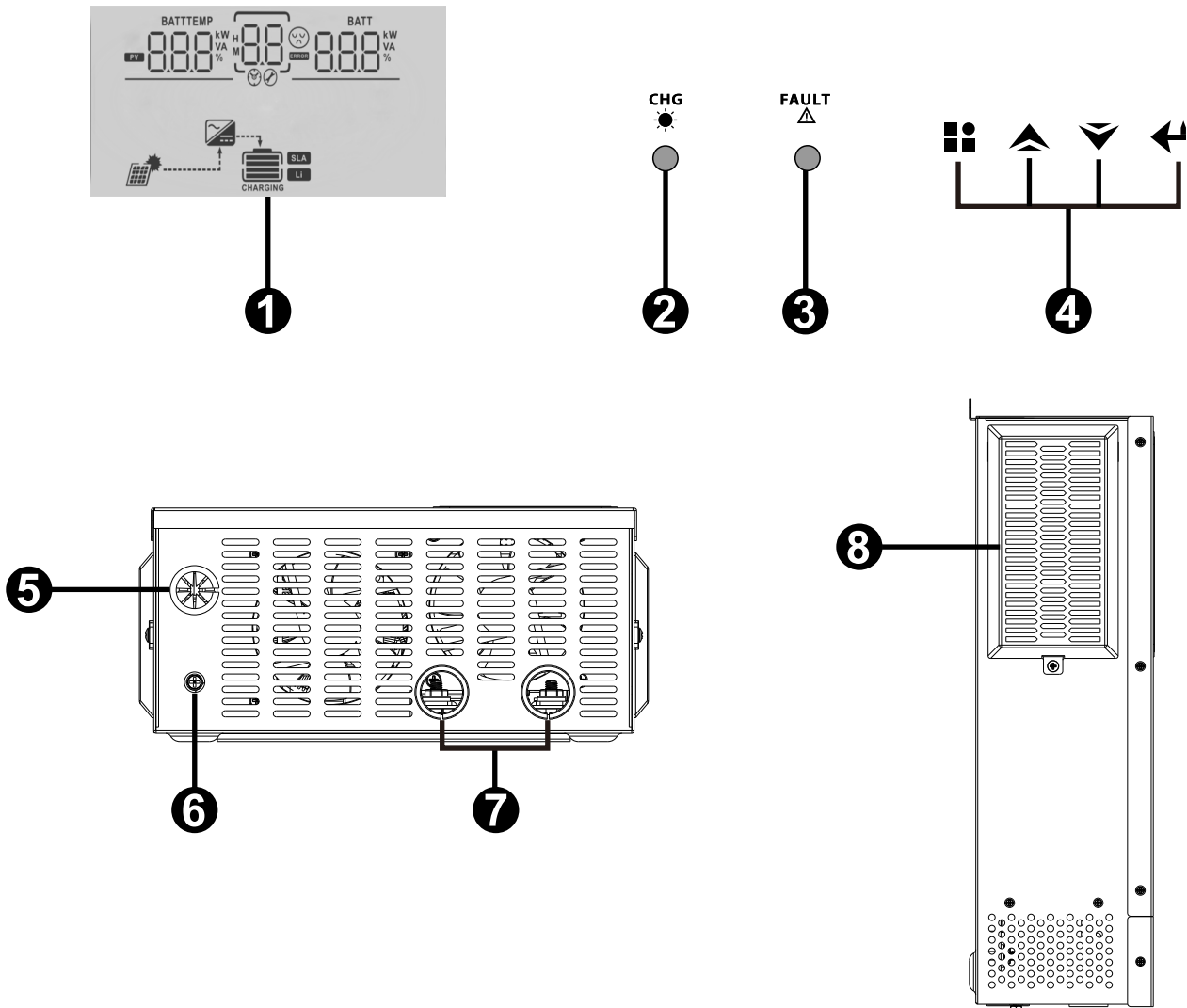

Figure 1 Hybrid Power System

### 3.3 Product Overview



1. LCD display
2. Charging indicator
3. Fault indicator
4. Function buttons
5. PV input
6. Ground Connection
7. Battery input
8. Anti dust kit

## 4 INSTALLATION

### 4.1 Unpacking and Inspection

Before installation, please inspect the unit. Be sure that nothing inside the package is damaged. You should have received the following items inside of package:

- ☑ The unit x 1
- ☑ User manual x 1

### 4.2 Preparation

Before connecting all wirings, please take off bottom cover by removing two screws as shown below.

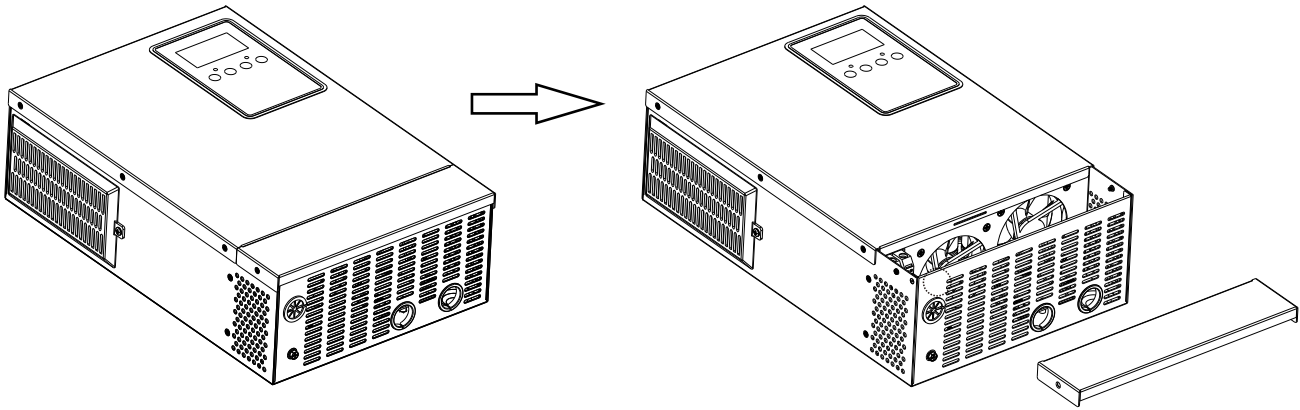

### 4.3 Mounting the Unit

Consider the following points before selecting where to install:

- ⌘ Do not mount the charger on flammable construction materials.
- ⌘ Mount on a solid surface
- ⌘ Install this charger at eye level in order to allow the LCD display to be read at all times.
- ⌘ For proper air circulation to dissipate heat, allow a clearance of approx. 20 cm to the side and approx. 50 cm above and below the unit.
- ⌘ The ambient temperature should be between 0°C and 55°C to ensure optimal operation.
- ⌘ The recommended installation position is to be adhered to the wall vertically.
- ⌘ Be sure to keep other objects and surfaces as shown in the diagram to guarantee sufficient heat dissipation and to have enough space for removing wires.

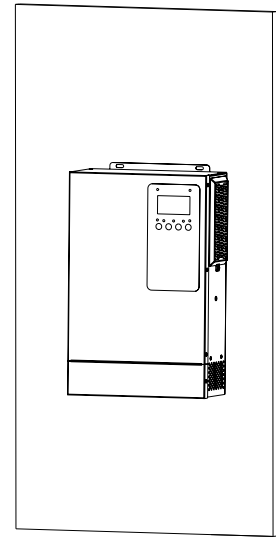

**SUITABLE FOR MOUNTING ON CONCRETE OR OTHER NON-COMBUSTIBLE SURFACE ONLY.**

Install the unit by screwing two screws. It's recommended to use M6 screws.

### 4.4 Battery Connection

**CAUTION:** For safety operation and regulation compliance, it's requested to install a separate DC over-current protector or disconnect device between battery and charger. It may not be requested to have a disconnect device in some applications, however, it's still requested to have over-current protection installed. Please refer to typical amperage in below table as required fuse or breaker size.

**WARNING!** All wiring must be performed by a qualified personnel.

**WARNING!** It's very important for system safety and efficient operation to use appropriate cable for battery connection. To reduce risk of injury, please use the proper recommended cable as below.

**Recommended battery cable size:**

Model	Wire Size	Cable (mm <sup>2</sup> )	Torque value (max)
24V/140A 48V/140A	1 x 2AWG	25	2 Nm

Please follow below steps to implement battery connection:

1. Remove insulation sleeve 18 mm for positive and negative conductors.
2. Suggest to put bootlace ferrules on the end of positive and negative wires with a proper crimping tool.

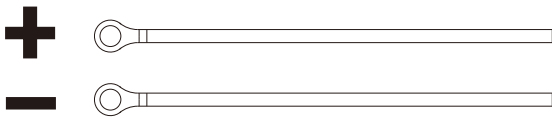

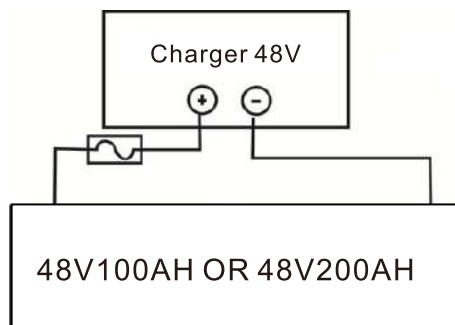
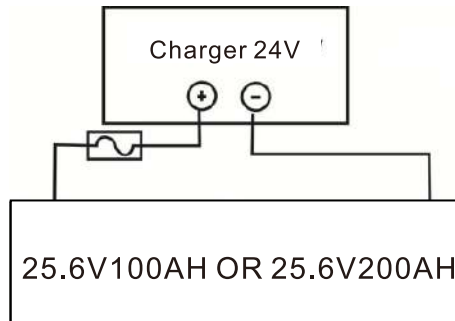

3. Connect all battery packs as below chart.

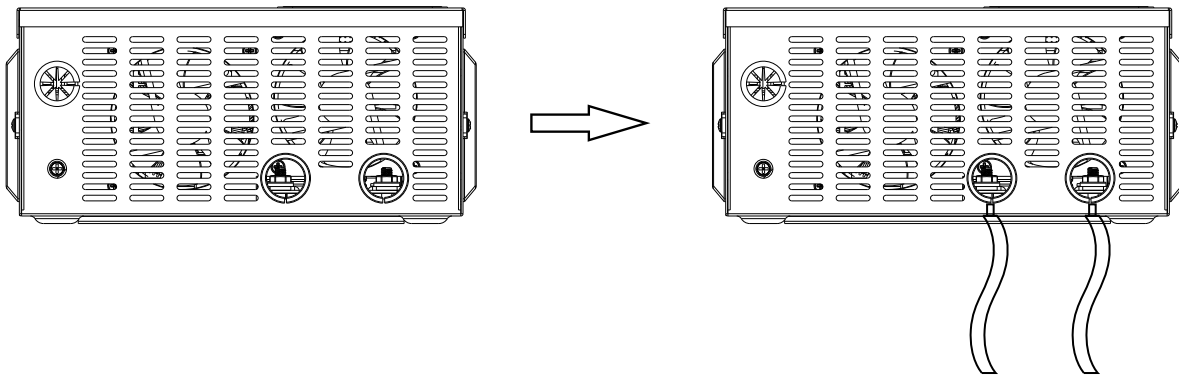

4. Insert the battery wires flatly into battery connectors of charger and make sure the bolts are tightened with torque of 2 Nm in clockwise direction. Make sure polarity at both the battery and the charge is correctly connected and conductors are tightly screwed into the battery terminals.

Recommended tool: #2 Pozi Screwdriver



	<p><b>WARNING: Shock Hazard</b></p> <p>Installation must be performed with care due to high battery voltage in series.</p>
	<p><b>CAUTION!!</b> Before making the final DC connection or closing DC breaker/disconnector, be sure positive (+) must be connected to positive (+) and negative (-) must be connected to negative (-).</p>

#### 4.5 PV Connection

**CAUTION:** Before connecting to PV modules, please install **separately** a DC circuit breaker between charger and PV modules.

**WARNING!** It's very important for system safety and efficient operation to use appropriate cable for PV module connection. To reduce risk of injury, please use the proper recommended cable size as below.

Model	Wire Size	Cable (mm <sup>2</sup> )	Torque value (max)
24V/140A 48V/140A	1 x 12AWG	4	1.2 Nm

#### **PV Module Selection:**

When selecting proper PV modules, please be sure to consider below parameters:

1. Open circuit Voltage (Voc) of PV modules not exceeds max. PV array open circuit voltage of charger
2. Open circuit Voltage (Voc) of PV modules should be higher than min. battery voltage.

MODEL	24V/140A	48V/140A
<b>Max. PV Array Open Circuit Voltage</b>	500Vdc	
<b>PV Array MPPT Voltage Range</b>	60Vdc~500Vdc	

Take 250Wp PV module as an example. After considering above two parameters, the recommended module configurations are listed as below table.



Solar Panel Spec. (reference)	SOLAR INPUT	Q'ty of panels	Total input power
	(Min in serial: 6 pcs, max. in serial: 13 pcs)		
- 250Wp	6 pcs in serial	6 pcs	1500W
- Vmp: 30.1Vdc	8 pcs in serial	8 pcs	2000W
- Imp: 8.3A	12 pcs in serial	12 pcs	3000W
- Voc: 37.7Vdc	13 pcs in serial	13 pcs	3250W
- Isc: 8.4A	8 pieces in serial and 2 sets in parallel	16 pcs	4000W
- Cells: 60	10 pieces in serial and 2 sets in parallel	20 pcs	5000W
	10 pieces in serial and 2 sets in parallel	20 pcs	6200W
	12 pieces in serial and 2 sets in parallel	24 pcs	6500W

### PV Module Wire Connection

Please follow below steps to implement PV module connection:

1. Remove insulation sleeve 10 mm for positive and negative conductors.
2. Suggest to put bootlace ferrules on the end of positive and negative wires with a proper crimping tool.
3. Check correct polarity of wire connection from PV modules and PV input connectors. Then, connect positive pole (+) of connection wire to positive pole (+) of PV input connector. Connect negative pole (-) of connection wire to negative pole (-) of PV input connector.  
Recommended tool: 4mm blade screwdriver

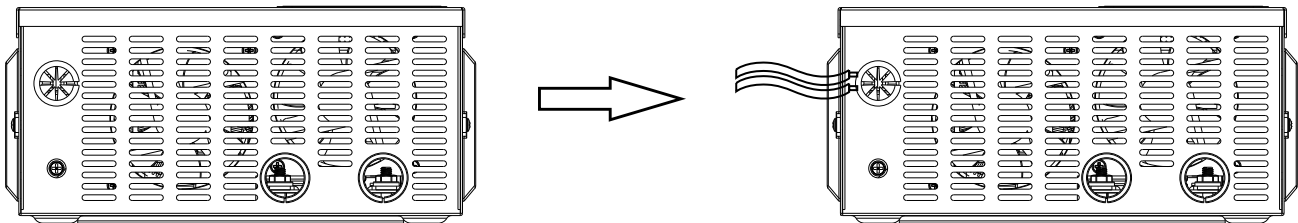
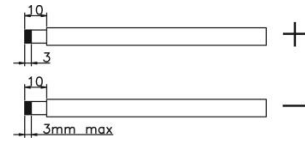

### 4.6 Final Assembly

After connecting all wirings, please put bottom cover back by screwing two screws as shown below.

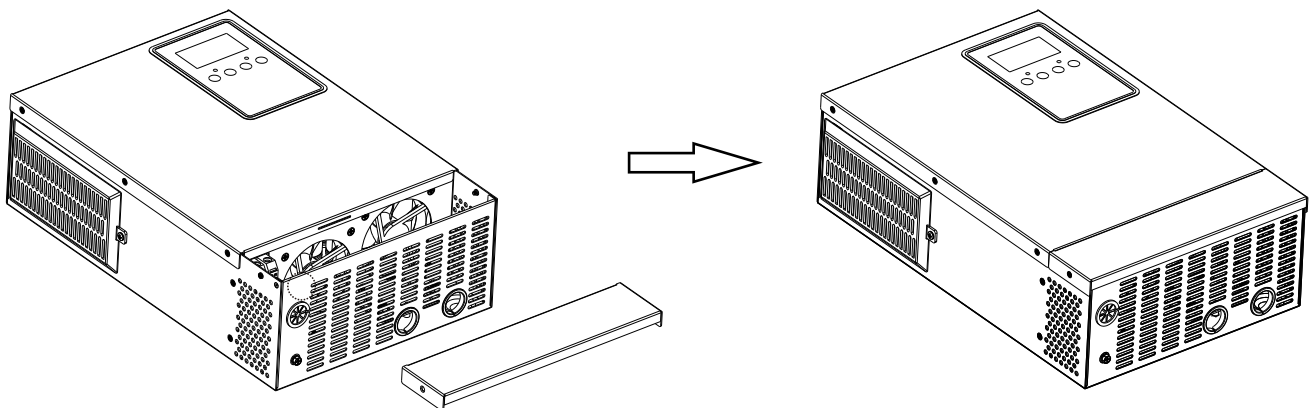

## 5 OPERATION

### 5.1 Operation and Display Panel

The operation and display panel, shown in below chart, is on the front panel of the inverter. It includes two indicators, two function keys and a LCD display, indicating the operating status and PV power information.

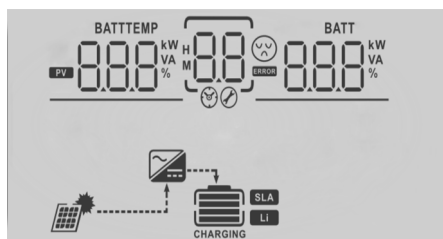

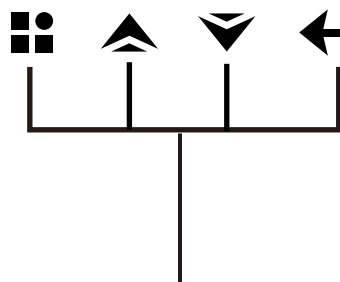

LCD display



Function keys

#### LED Indicator

LED Indicator		Messages	
<b>CHG</b> 	Green	Solid On	Battery is fully charged.
		Flashing	Battery is charging.
<b>FAULT</b> 	Red	Solid On	Fault occurs in the charger
		Flashing	Warning condition occurs in the charger

#### Function Keys









Function Key	Description
ESC	To exit setting mode
UP	To go to previous selection
DOWN	To go to next selection
ENTER	To confirm the selection in setting mode or enter setting mode

## 5.2 LCD Setting

After pressing and holding ENTER button for 3 seconds, the unit will enter setting mode. Press "DOWN" button to select setting programs. And then, press "ENTER" button to confirm the selection or press "ENTER" button second to exit.

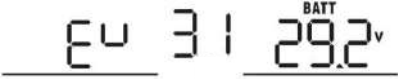
### Setting Programs:

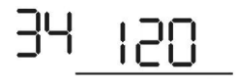
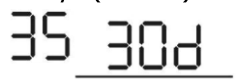



Program	Description	Selectable option		
00	Exit setting mode	Escape (default) 00 00E	One-button restore setting options	
		00 00H		
02	Maximum charging current	10A 02 10 <sup>A</sup>	20A 02 20 <sup>A</sup>	30A 02 30 <sup>A</sup>
		40A 02 40 <sup>A</sup>	50A 02 50 <sup>A</sup>	60A (default) 02 60 <sup>A</sup>
		70A 02 70 <sup>A</sup>	80A 02 80 <sup>A</sup>	90A 02 90 <sup>A</sup>
		100A 02 100 <sup>A</sup>	110A 02 110 <sup>A</sup>	120A 02 120 <sup>A</sup>
		130A 02 130 <sup>A</sup>	140A 02 140 <sup>A</sup>	
05	Battery type	05 AG <sub>n</sub>	Flooded 05 FL <sub>d</sub>	
		05 USE	If "User-Defined" is selected, battery charge voltage can be set up in program 26, 27 and 29.	
07	Auto restart when over temperature occurs	Restart disable (default) 07 tTd	Restart enable 07 tTE	
26	Bulk charging voltage (C.V voltage)	24V default setting: 28.2V CU 26 28.2 <sup>BATT</sup> v		
		48V default setting: 56.4V CU 26 56.4 <sup>BATT</sup> v		

		If self-defined is selected in program 5, this program can be set up. Setting range is from 25.0V to 29.5V for 24V model and 48.0V to 59.0V for 48V model. Increment of each click is 0.1V.	
27	Floating charging voltage	24V default setting: 27.0V 	
		48V default setting: 54.0V 	
		If self-defined is selected in program 5, this program can be set up. Setting range is from 25.0V to 29.5V for 24V model and 48.0V to 59.0V for 48V model. Increment of each click is 0.1V.	
30	Battery equalization	Battery equalization 	Battery equalization disable (default) 
		If "Flooded" or "User-Defined" is selected in program 05, this program can be set up.	
31	Battery equalization voltage	24V default setting: 29.2V 	
		48V default setting: 58.4V 	
		Setting range is from 25.0V to 29.5V for 24V model and 48.0V to 59.0V for 48V model. Increment of each click is 0.1V.	
33	Battery equalized time	60min (default) 	Setting range is from 5min to 900min. Increment of each click is 5min.
34	Battery equalized timeout	120min (default) 	Setting range is from 5min to 900 min. Increment of each click is 5 min.
35	Equalization interval	30days (default) 	Setting range is from 0 to 90 days. Increment of each click is 1 day
36	Equalization activated immediately	Enable 	Disable (default) 
		If equalization function is enabled in program 30, this program can be set up. If "Enable" is selected in this program, it's to activate battery equalization immediately and LCD main page will shows "E9". If "Disable" is selected, it will cancel equalization function until next activated equalization time arrives based on program 35 setting. At this time, "E9" will not be shown in LCD main page.	

81	Year set	81 <u>00</u>	81 <u>01</u>	.....	81 <u>98</u>	81 <u>99</u>
82	Month set	82 <u>01</u>	82 <u>02</u>	.....	82 <u>11</u>	82 <u>12</u>
83	Day set	83 <u>01</u>	83 <u>02</u>	.....	83 <u>30</u>	83 <u>31</u>
84	Hour set	84 <u>00</u>	84 <u>01</u>	.....	84 <u>23</u>	84 <u>24</u>
85	Miunte set	85 <u>00</u>	85 <u>01</u>	.....	85 <u>59</u>	85 <u>60</u>
86	Clearn Energy	86 <u>ENABLE</u>			86 <u>DISABLE</u>	

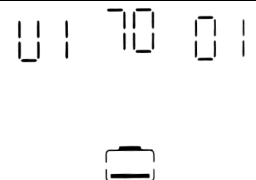
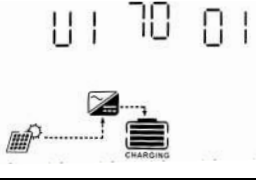
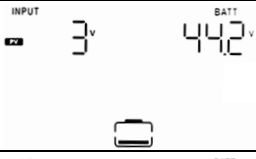
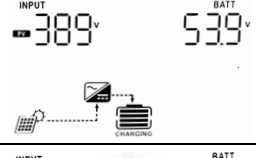
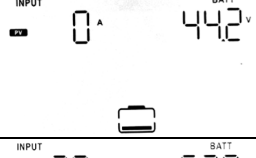
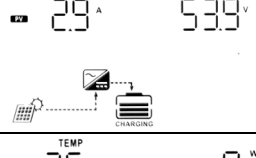
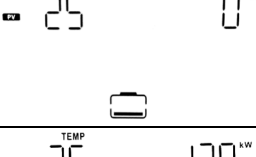
### 5.3 Display

The LCD display information will be switched in turns by pressing "UP" or "DOWN" key. The selectable information is switched as below order: PV voltage, charging current, charging power, battery voltage, main CPU Version.

Selectable information		LCD display
Version number	Stand by	
	Charging	
PV voltage	Stand by	
	Charging	
PV current	Stand by	
	Charging	
PV temperature/PV power	Stand by	
	Charging	
Charge current/ Battery voltage	Stand by	
	Charging	

Charge power	Stand by	
	Charging	
Daily power generation	Stand by	
	Charging	
Monthly power generation	Stand by	
	Charging	
Gross generation	Stand by	
	Charging	
Date	Stand by	
	Charging	
Time	Stand by	
	Charging	

## 5.4 Battery Equalization Description

Equalization function is added into charge controller. It reverses the buildup of negative chemical effects like stratification, a condition where acid concentration is greater at the bottom of the battery than at the top. Equalization also helps to remove sulfate crystals that might have built up on the plates. If left unchecked, this condition, called sulfation, will reduce the overall capacity of the battery. Therefore, it's recommended to equalize battery periodically.

### ⌘ How to Apply Equalization Function

You must enable battery equalization function in monitoring LCD setting program 05 first. Then, you may apply this function in device by either one of following methods:

1. Setting equalization interval in program 09.
2. Active equalization immediately in program 10.

### ⌘ When to Equalize

In float stage, when the setting equalization interval (battery equalization cycle) is arrived, or equalization is active immediately, the controller will start to enter Equalize stage.

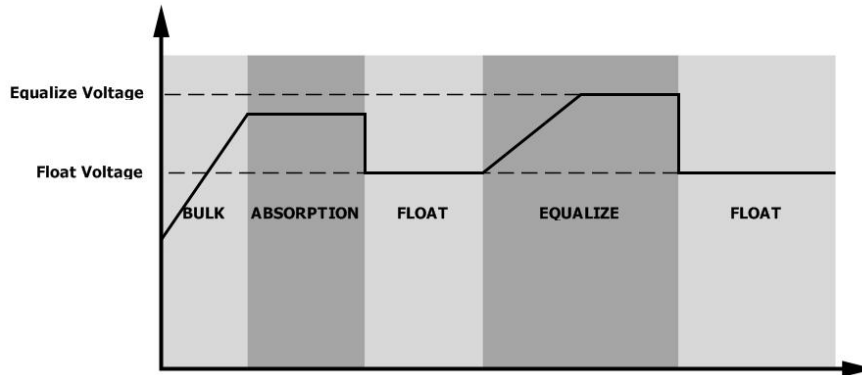

### ⌘ Equalize charging time and timeout

In Equalize stage, the controller will supply power to charge battery as much as possible until battery voltage raises to battery equalization voltage. Then, constant-voltage regulation is applied to maintain battery voltage at the battery equalization voltage. The battery will remain in the Equalize stage until setting battery equalized time is arrived.

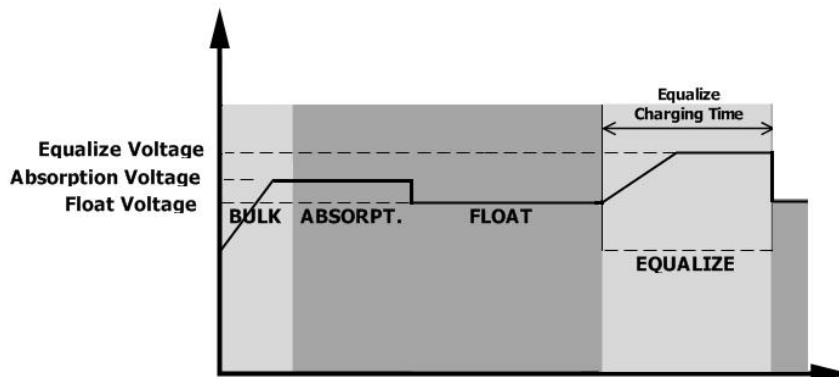



However, in Equalize stage, when battery equalized time is expired and battery voltage doesn't rise to battery equalization voltage point, the charge controller will extend the battery equalized time until battery voltage achieves battery equalization voltage. If battery voltage is still lower than battery equalization voltage when battery equalized timeout setting is over, the charge controller will stop equalization and return to float stage.

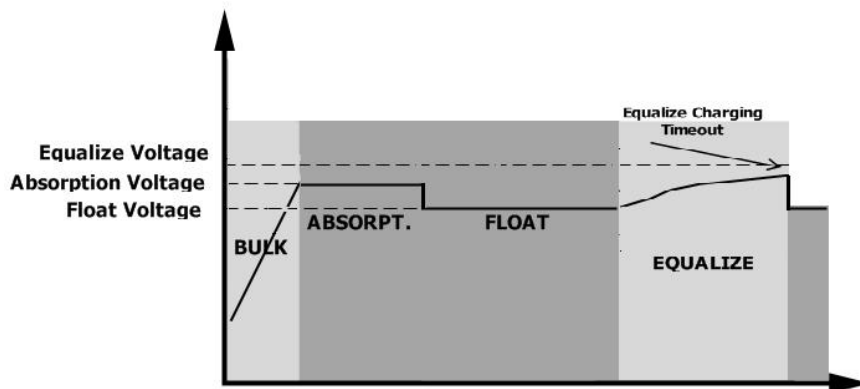

### 5.5 Fault Reference Code

Fault Code	Fault Event	Icon on
01	Fan is locked when inverter is off.	01 <sub>ERROR</sub>
02	Over temperature	02 <sub>ERROR</sub>
03	Battery voltage is too high	03 <sub>ERROR</sub>
08	Bus voltage is too high	08 <sub>ERROR</sub>
09	Bus soft start failed	09 <sub>ERROR</sub>
51	Over current or surge	51 <sub>ERROR</sub>
52	Bus voltage is too low	52 <sub>ERROR</sub>
57	Current sensor failed	57 <sub>ERROR</sub>
59	PV voltage is over limitation	59 <sub>ERROR</sub>

### 5.6 Warning Indicator

Warning Code	Warning Event	Audible Alarm	Icon flashing
E9	Battery equalization	None	E9 <sup>⊕</sup>
bP	Battery is not connected	None	bP <sup>⊕</sup>

## 6 CLEARANCE AND MAINTENANCE FOR ANTI-DUST KIT

### 6.1 Overview

Every charge is already installed with anti-dusk kit from factory. Charge will automatically detect this kit and activate internal thermal sensor to adjust internal temperature. This kit also keeps dusk from your charge and increases product reliability in harsh environment.

### 6.2 Clearance and Maintenance

**Step 1:** Please loosen the screw in counterclockwise direction on the top of the charge.

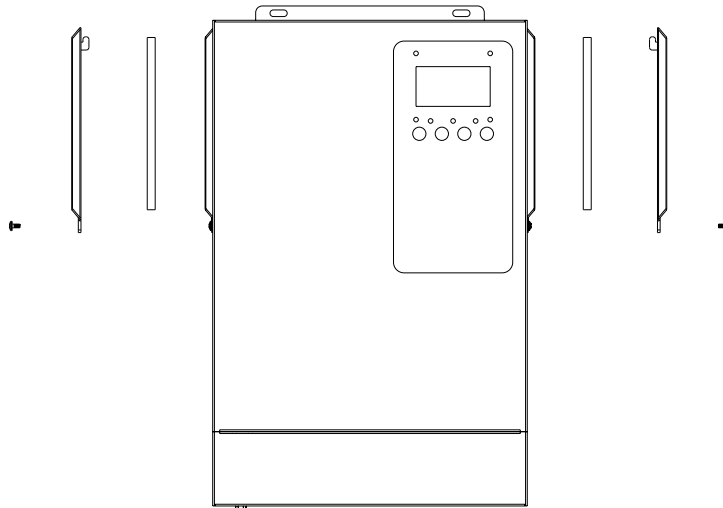

**Step 2:** Then, dustproof case can be removed and take out air filter foam as shown in below chart.

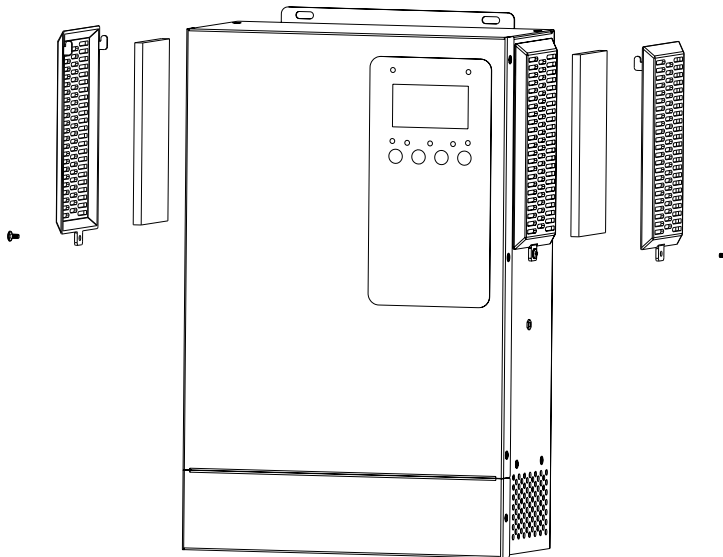

**Step 3:** Clean air filter foam and dustproof case. After clearance, re-assemble the dust-kit back to the charger.

**NOTICE:** The anti-dust kit should be cleaned from dust every one month.

## 7 CHARGE MODE SPECIFICATIONS

MPPT Solar Charging Mode		
MODEL	24V	48V
Max. PV Array Power	4200W	6500W
Nominal PV Voltage	180Vdc	280Vdc
PV Array MPPT Voltage Range	60Vdc~450Vdc	
Max. PV Array Open Circuit Voltage	500Vdc	
Max Charging Current (AC charger plus solar charger)	140Amp	140Amp
Charging Curve		

## 8 TROUBLE SHOOTING

Problem	LCD/LED/Buzzer	Explanation / Possible cause	What to do
Unit shuts down automatically during startup process.	LCD/LEDs and buzzer will be active for 3 seconds and then complete off.	The battery voltage is too low (<1.91V/Cell)	1. Re-charge battery. 2. Replace battery.
No response after power on.	No indication.	1. The battery voltage is far too low. (<1.4V/Cell) 2. Internal fuse tripped.	1. Contact repair center for replacing the fuse. 2. Re-charge battery. 3. Replace battery.
Red LED is on.	Fault code 02	Internal temperature of charger component is over 70 °C.	Check whether the air flow of the unit is blocked or whether the ambient temperature is too high.
	Fault code 03	Battery is over-charged.	Return to repair center.
		The battery voltage is too high.	Check if spec and quantity of batteries are meet requirements.
	Fault code 01	Fan fault	Replace the fan.
Fault code 52	Bus voltage is too low.	Restart the unit, if the error happens again, please return to repair center.	



# POWMr

SHENZHEN HEHEJIN INDUSTRIAL CO.,LTD

Tel/Fax: +86 755-28219903

Email: [support@powmr.com](mailto:support@powmr.com)

Web: [www.powmr.com](http://www.powmr.com)

Add: Henggang Street, Longgang District, Shenzhen, Guangdong, China

技术要求：单页尺寸142\*210mm；  
材质：封面105g铜版纸,内页80g书写纸；  
料号打于后封面左下角；  
注：此技术要求不用印刷