

AXe | STRUCT

DS_AXE_RT_BL_RD
Product data sheet
AXE^{RT} BL – Roof Top Ballast

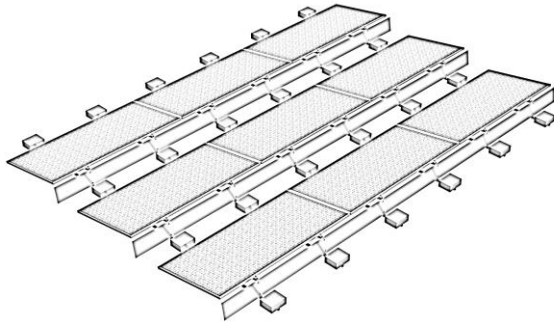

AXE^{RT}

Roof Top – Ballast Railed

Durable

Aluminium structures with stainless steel fittings for the toughest environmental conditions.

Trust

Conservative coefficient selections in structural design to assure resistance to failure.

Economical

Cost competitive, functional design with minimal number of tools needed, reducing installation costs.

Effortless

Innovative design for time saving installation methods with a modular and practical integrated solution.

Mono Pitch



Duo Pitch



Additions	Cable clips to panel frames	
Roof types	Flat concrete roof Consult for other roof types	
Module orientation	Landscape	
Layout	One directional or East-West	
Inclination	10° or 15° angle	
Shading Angle	25° or preferred angle to optimise production	
Standards	SANS 10160	Structural design
	SANS 10162	Structural use of steel
	NEN 7250	Integration of solar systems on roofs
	Eurocode 9	Design of aluminium structure
Materials	Support rails and Incline angles	Extruded aluminium (6063 T6)
	Small parts	Stainless steel (A2) Extruded aluminium (6063 T6)
	Ballast blocks	Concrete (30 MPa)
	Wind deflector	Cold-rolled galvanised steel (Aluzinc) or Aluminium
Certification	ISO 9001	
Warranty	10 years ¹	

Clamp connection to Rail



Wind deflector plate

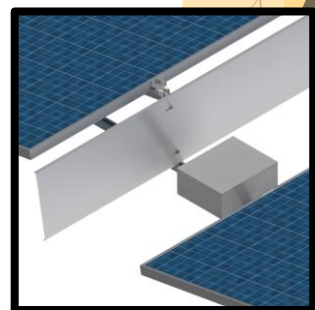

¹ For terms and conditions please refer to the Axe Struct Warranty Terms.