



**LEAPTON**  
SOLAR

Monocrystalline

Polycrystalline

# LP210\*210-M-60-MH

Rated Power 590-610W

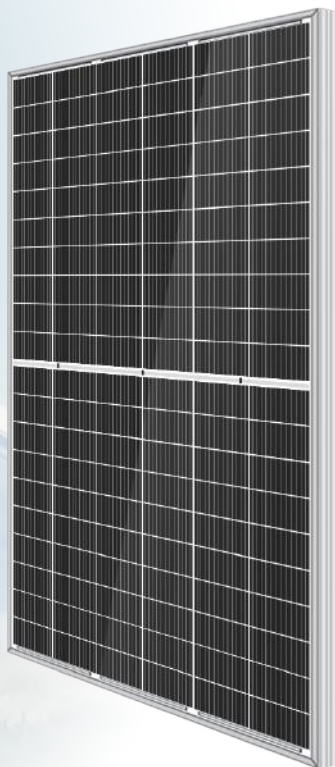

### MBB Cell

New circuit design, lower internal current, lower internal resistance loss.



### Low Light Features

Higher performance under low light environment.



### Higher Output Power

Module adopts 120 pcs of 210\*210mm half cells, the maximum power can reach 610W.



### PID Protection

Ensure the attenuation probability caused by PID phenomenon is minimized.



### Harsh Environmental Adaptability

Strict salt spray and ammonia corrosion test by TUV Nord.



### Load Capacity

Mechanical load tests including wind load 2400 Pa and snow load 5400 Pa done by TUV Nord.

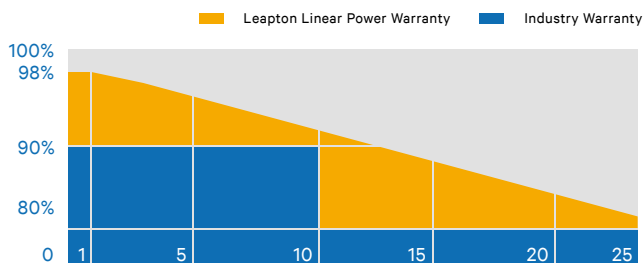

\*J-PEC Product



IEC 61215-2: 2016  
IEC 61730-2: 2016

Headquarter : Leapton Energy Co., Ltd.

Tosei Bldg. 6F, 1-2-1 Aioi-cho, Chuo-ku Kobe-shi, Hyogo, 650-0025, Japan

Manufacturer : Leapton Solar (Changshu) Co., Ltd.

No.9, Sunshine Avenue, Changshu City, Jiangsu, China

+81-78-382-3182

www.leaptonenergy.jp

+86-512-88800068

info@leaptonenergy.com

www.leaptonpv.com



## MECHANICAL DIAGRAMS

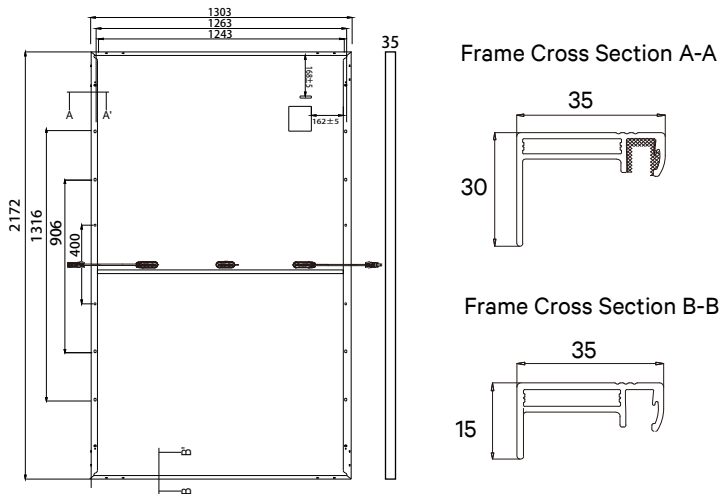

## SPECIFICATIONS

Weight	31kg
Dimensions	2172mm*1303mm*35mm
Cell Dimensions	210*210mm
Cell Amount	60*2 pcs
Maximum System Voltage	1500V
Junction Box	IP68
Frame	Aluminum Alloy
Cable	4mm <sup>2</sup> , Landscape: N 1300mm/P 1300mm Portrait: N 280mm/P 280mm
Connector	MC4 compatible
Application Level	Class A

## ELECTRICAL PARAMETERS AT STC

Power	590W	595W	600W	605W	610W
Open Circuit Voltage	41.10V	41.30V	41.50V	41.70V	41.90V
Short Circuit Current	18.42A	18.47A	18.52A	18.57A	18.62A
Maximum Power Voltage	34.00V	34.20V	34.40V	34.60V	34.80V
Maximum Power Current	17.35A	17.40A	17.44A	17.49A	17.53A
Module Efficiency	20.85%	21.02%	21.20%	21.38%	21.55%

\* Under Standard Test Conditions (STC) of irradiance of 1000 W/m<sup>2</sup>, spectrum AM 1.5 and cell temperature of 25°C.

## ELECTRICAL PARAMETERS AT NMOT

Power	451W	455W	459W	463W	467W
Open Circuit Voltage	38.14V	38.33V	38.51V	38.70V	38.88V
Short Circuit Current	15.10A	15.15A	15.19A	15.23A	15.27A
Maximum Power Voltage	31.52V	31.70V	31.89V	32.07V	32.26V
Maximum Power Current	14.32A	14.36A	14.39A	14.43A	14.43A
Module Efficiency	15.94%	16.08%	16.22%	16.36%	16.50%

\* Under Nominal Module Operating Temperature (NMOT), irradiance of 800 W/m<sup>2</sup>, spectrum AM 1.5, ambient temperature 20°C, wind speed 1 m/s.

## TEMPERATURE CHARACTERISTICS

NMOT	41±3°C	Temp Coefficient of ISC	+0.05%/°C
Temp Coefficient of VOC	-0.28%/°C	Temp Coefficient of Pmax	-0.36%/°C

## PACKING CONFIGURATION

Modules/Pallet	31 Pieces	Modules/40'Container	558 Pieces
Packing Description	18 Pallets, Total=31x18=558 Pieces		

## CHARACTERISTICS

LP210\*210-M-60-MH-590W

LP210\*210-M-60-MH-590W

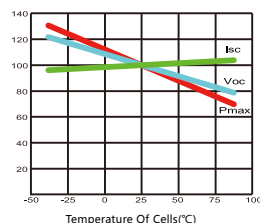
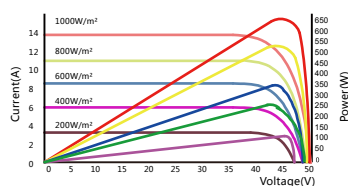

## MAXIMUM RATING

Output Tolerance	0~+5W
Operating Temperature	-40°C~+85°C
Wind Load/Snow Load	2400pa/5400pa
Fuse Current	30A

**15** YEARS  
Quality  
Warranty

**25** YEARS  
Power  
Warranty

Headquarter : Leapton Energy Co., Ltd.

☑ Tosei Bldg. 6F, 1-2-1 Aioi-cho, Chuo-ku Kobe-shi, Hyogo, 650-0025, Japan

☎ +81-78-382-3182

🌐 www.leaptonenergy.jp

Manufacturer : Leapton Solar (Changshu) Co., Ltd.

☑ No.9, Sunshine Avenue, Changshu City, Jiangsu, China

☎ +86-512-88800068

✉ info@leaptonenergy.com

🌐 www.leaptonpv.com