

RMI Series Inverter

Features

- RMI series inverter is mounted in racks(19"rack mounted) from 500VA up to 10KVA, with inverter modules of 0.7/0.8 power factor.
- RMI series inverter adopts microcomputer CPU for intelligent control, and it has simple and reliable control circuit for high-speed response to changing environment;
- RMI series inverter adopts SPWM technology to output pure sine wave which has stable frequency, stable voltage, low noise and low degree of distortion;
- RMI series inverter has strong loading capacity, strong load adaptability, and built-in bypass switch to ensure continuous and stable power supply;
- The DC input end of RMI series inverter adopts noise reduction technology to avoid interference with other communication equipments that share the same DC cabinet. The AC input end of RMI series inverter adopts multiple filtering technology to avoid interference from AC and meet the demand of application system for master AC power supply;
- RMI series inverter is applicable to set AC or DC as master power supply (optional but only one):
 - * a) with electric supply, AC as master power supply: remains AC output in case it is available and switches to DC output in case AC supply is interrupted;
 - * b) with electric supply, DC as master power supply: remains DC output in case AC is available, and switches to AC output in case DC supply is interrupted;
- RMI series inverter has scientific design, and it automatically switches to AC bypass in case DC supply is cut off in running status, which doesn't affect power supply and facilitate the maintenance and replacement of storage battery;
- RMI series inverter cuts off power supply in case of high/low battery voltage alarm or overload alarm, and resumes power supply when the battery voltage resumes normal status, therefore, RMI series inverter is quite applicable to unattended communication base station;
- RMI series inverter has a LCD display, so that it is easy for the user to check the working status. The LCD display adopts 1602B, 122*32 dot matrix, silver white text against blue background;
- RMI series inverter supports AC starting in case of DC supply is interrupted (optional);
- RMI series inverter supports communication function and real-time monitoring function through monitoring software (optional);
- RMI series inverter supports TCP/IP protocol, so that the user can utilize Ether CAT and monitoring software to achieve remote and real-time monitoring of working status (optional);
- RMI series inverter has three groups of passive dry contacts to meet the emergencies of DC input failure, AC input failure or AC output failure (optional).



Inverter Function Diagram

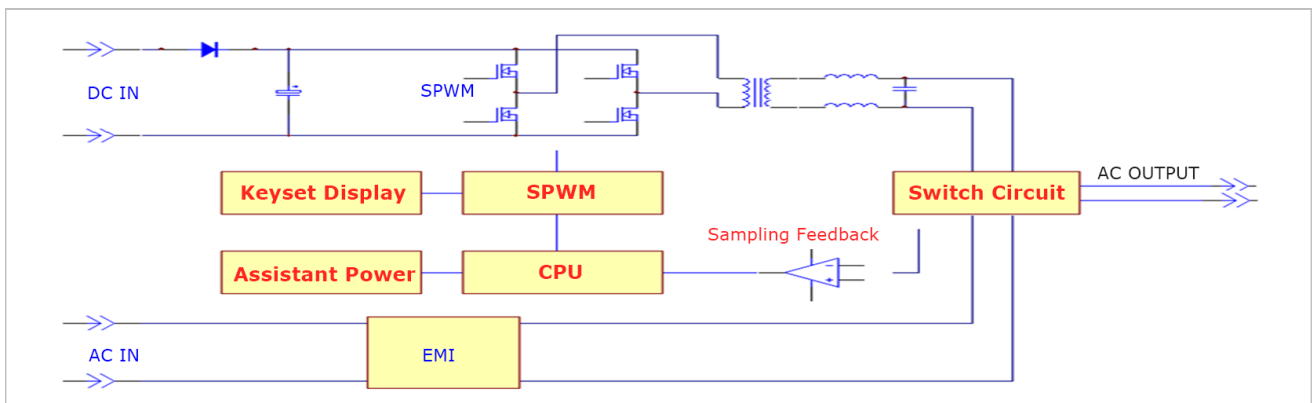

Technical data

MODEL (HV)	RMI500	RMI1000	RMI1500	RMI2000	RMI2500	RMI3000	RMI5000	RMI6000	RMI8000	RMI10000
Capacity	500VA	1000VA	1500VA	2000VA	2500VA	3000VA	5000VA	6000VA	8000VA	10000VA
	400W	800W	1200W	1600W	2000W	2400W	3500W	4200W	5600W	7000W

INPUT (DC INPUT & BYPASS INPUT)

Input Voltage (Vdc)	12/24V	24/48/ 110/220V	24V	24/48/ 110/220V	24/48V	24/48/ 110/220V	48/110/ 220V	48/110/ 220V	48/220V	48/220V
Reverse Noise Current	≤10%									
Bypass Volt (Vac)	185-265V(±10V)									
Transfer Time (ms)	≤5ms									

OUTPUT

Voltage and Frequency	220/230/240Vac,50Hz/60Hz									
Voltage Precision	220/230/240Vac±1.5%									
Frequency Precision	50Hz/60Hz±0.1%									
Waveform	Pure Sine Wave									
Wave Distortion	THDu≤3%(linear load)									
Power Factor	0.8(0.5k-3k)/0.7(5k-10k)									
Overload	surge 200%, 120%,30 second									
Inversion Efficiency	≥90%									

SYSTEM

Noise	≤40dB(1 meter away)									
Temperature	-25℃ ~ +60℃(storage)/-20℃ ~ +50℃(operation)									
Humidity	0 ~ 90%(non-condensing)									
Altitude	≤2000m									
Display	LED+LCD									
Interface	RJ45, RS232 and Dry contractor									
Dimension (W*D*H) (cm)	56.5*38.5*17(RMI 500); 57.5*48.5*22.5(RMI 1000/1500/2000); 57.5*51.5*23.8[RMI 2500/3000/5000(2U)]; 59.5*57.5*30.3 [RMI5000(4U)/6000/8000/10000(4U)]; 54*53*42 [RMI10000(8U)]									
Weight (kg)	7kg(RMI 500); 11kg(RMI 1000/1500/2000); 12kg(RMI 2500/3000); 14kg[RMI 5000(2U)]; 22kg[RMI 5000(4U)/6000]; 25kg[RMI 8000/10000(4U)]; 50kg[RMI 10000(8U)]									

Technical data

MODEL (LV)	RMI500	RMI1000	RMI1500	RMI2000	RMI3000	RMI5000	RMI6000
Capacity	500VA	1000VA	1500VA	2000VA	3000VA	5000VA	6000VA
	400W	800W	1200W	1600W	2400W	3500W	4200W

INPUT (DC INPUT & BYPASS INPUT)

Input Voltage (Vdc)	24V	24/48/ 110/220V	24V	24/48/ 110/220V	48/110/220V	48/110/220V	220V
Reverse Noise Current	≤10%						
Bypass Volt (Vac)	92-130V(±10V)						
Transfer Time (ms)	≤5ms						

OUTPUT

Voltage and Frequency	110/120/130Vac,50Hz/60Hz						
Voltage Precision	110/120/130Vac±1.5%						
Frequency Precision	50Hz/60Hz±0.1%						
Waveform	Pure Sine Wave						
Wave Distortion	THDu≤3%(linear load)						
Power Factor	0.8(0.5k-3k)/0.7(5k-6k)						
Overload	surge 200%, 120%,30 sec						
Inversion Efficiency	≥90%						

SYSTEM

Noise	≤40dB(1 meter away)						
Temperature	-25℃~+60℃(storage)/-20℃~+50℃(operation)						
Humidity	0~90%(non-condensing)						
Altitude	≤2000m						
Display	LED+LCD						
Interface	RJ45, RS232 and Dry contractor						
Dimension (W*D*H) (cm)	56.5*38.5*17(RMI 500); 57.5*48.5*22.5(RMI 1000/1500/2000); 57.5*51.5*23.8[RMI 3000/5000(2U)]; 59.5*57.5*30.3 [RMI5000(4U)/6000]						
Weight (kg)	7kg(RMI 500); 11kg(RMI 1000/1500/2000); 12kg(RMI 3000); 14kg[RMI 5000(2U)]; 22kg[RMI 5000(4U)/6000]						