

The rechargeable batteries are lead-lead dioxide systems. The dilute sulfuric acid electrolyte is absorbed by separators and plates and thus immobilized. Should the battery be accidentally overcharged producing hydrogen and oxygen, special oneway valves allow the gases to escape thus avoiding excessive pressure build-up. Otherwise, the battery is completely sealed and is, therefore, maintenance-free, leak proof and usable in any position.



Battery Construction

| | | | | | | | | |
|--------------|----------------|----------------|-----------|-------|--------------|----------|------------|---------------|
| Component | Positive plate | Negative plate | Container | Cover | Safety valve | Terminal | Separator | Electrolyte |
| Raw material | Lead dioxide | Lead | ABS | ABS | Rubber | Copper | Fiberglass | Sulfuric acid |

General Feature

- Absorbent Glass Mat(AGM) technology for efficient gas recombination of up to 99% and freedom from electrolyte maintenance or water adding.
- Not restricted for air transport-complies with IATA/ICAO Special Provision A67.
- UL-recognized component.
- Can be mounted in any orientation.
- Computer designed lead, calcium tin alloy grid for high power density.
- Long service life, float or cyclic applications.
- Maintenance-free operation.
- Low self discharge.

Performance Characteristics

| | | |
|---|--|--------|
| Capacity 77°F(25°C) | 20 hour rate (1.0A、10.5V) | 20Ah |
| | 10 hour rate (1.75A、10.5V) | 17.5Ah |
| | 5 hour rate (3.4A、10.5V) | 17.0Ah |
| | 1 hour rate (14A、9.6V) | 14Ah |
| Internal Resistance | Full charged Battery77°F(25°C):11mΩ | |
| Capacity affected by Temperature (20 hour rate) | 104° F(40°C) | 102% |
| | 77° F(25°C) | 100% |
| | 32° F(10°C) | 85% |
| | 5° F(-15°C) | 65% |
| Self-Discharge 68°F(20°C) | Capacity after 3 month storage | 90% |
| | Capacity after 6 month storage | 80% |
| | Capacity after 12month storage | 60% |
| Max. discharge current77°F(25°C): 300A(5S) | | |
| Charge (Constant Voltage) | Float: 13.6~13.8 V/77° F(25°C) | |
| | Cycle:14.5~14.9 V/77°F(25°C) Max. Current: 5A | |

SPECIFICATION

Nominal voltage 12V
 Number of cell 6
 Length(mm/inch) 181/7.13
 Width(mm/inch) 77/3.03
 Height(mm/inch) 167/6.57
 Total Height(mm/inch) 167/6.57
 Approx. Weight(kg/lbs) 5.4/11.9

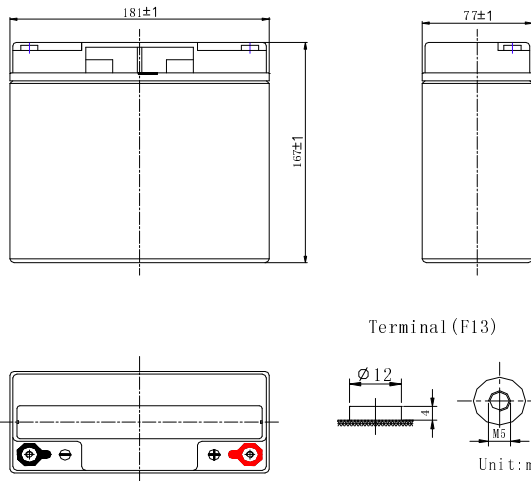

Discharge Constant Current (Amperes at 77° F25 °C)

| End Point Volts/Cell | 5min | 10min | 15min | 30min | 1h | 3h | 5h | 10h | 20h |
|----------------------|------|-------|-------|-------|------|------|------|------|------|
| 1.60V | 75.0 | 53.5 | 42.5 | 24.5 | 14.0 | 5.60 | 3.60 | 1.81 | 1.02 |
| 1.65V | 72.7 | 52.5 | 41.7 | 23.9 | 13.7 | 5.48 | 3.54 | 1.79 | 1.02 |
| 1.70V | 70.3 | 51.4 | 40.8 | 23.3 | 13.4 | 5.35 | 3.47 | 1.77 | 1.01 |
| 1.75V | 67.8 | 50.2 | 39.9 | 22.6 | 13.0 | 5.20 | 3.40 | 1.75 | 1.00 |
| 1.80V | 65.1 | 48.9 | 38.9 | 21.8 | 12.6 | 5.05 | 3.30 | 1.72 | 0.98 |

Discharge Constant Power (watts at 77° F 25 °C)

| End Point Volts/Cell | 5min | 10min | 15min | 30min | 45min | 1h | 2h | 3h | 5h |
|----------------------|------|-------|-------|-------|-------|------|------|------|------|
| 1.60V | 145 | 102 | 80.5 | 46.5 | 34.5 | 27.5 | 15.3 | 11.0 | 7.10 |
| 1.65V | 141 | 100 | 79.0 | 45.5 | 33.9 | 27.1 | 15.1 | 10.8 | 7.00 |
| 1.70V | 136 | 97.5 | 77.2 | 44.4 | 33.2 | 26.7 | 14.8 | 10.6 | 6.90 |
| 1.75V | 130 | 95.0 | 75.2 | 43.2 | 32.5 | 26.2 | 14.5 | 10.4 | 6.80 |
| 1.80V | 123 | 92.0 | 73.0 | 41.7 | 31.7 | 25.7 | 14.1 | 10.2 | 6.65 |

(Note)The above characteristics data are average values obtained Within three charge/discharge cycles not the minimum values.

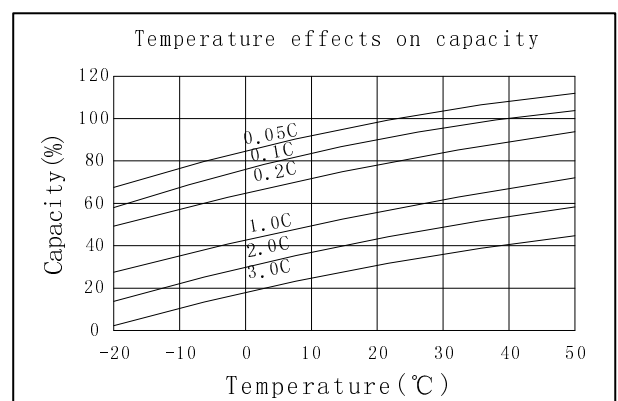
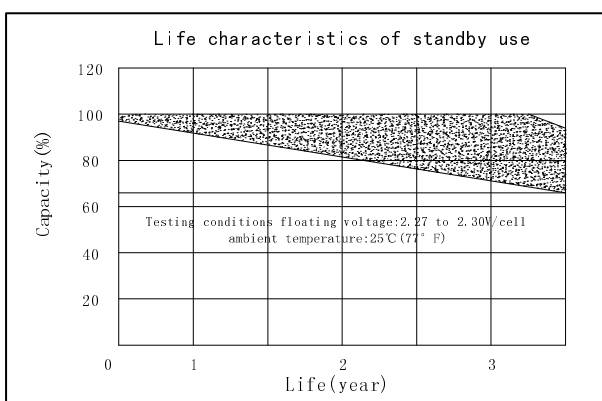
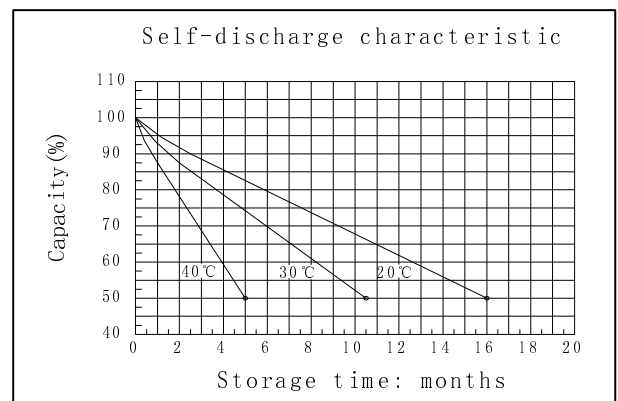
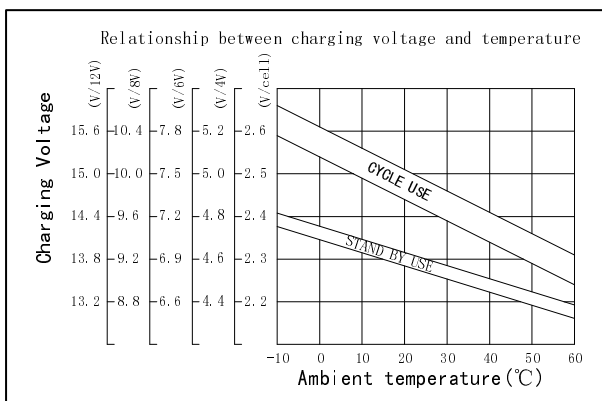
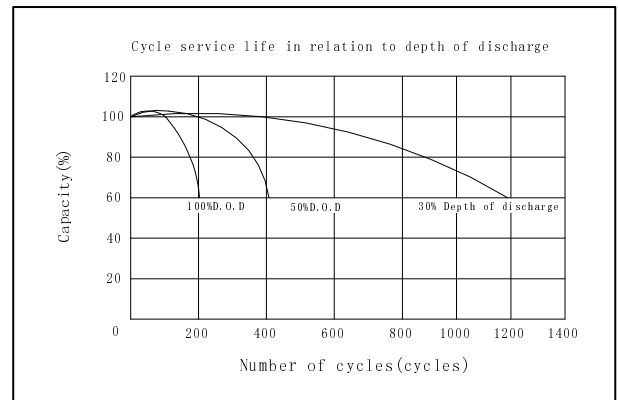
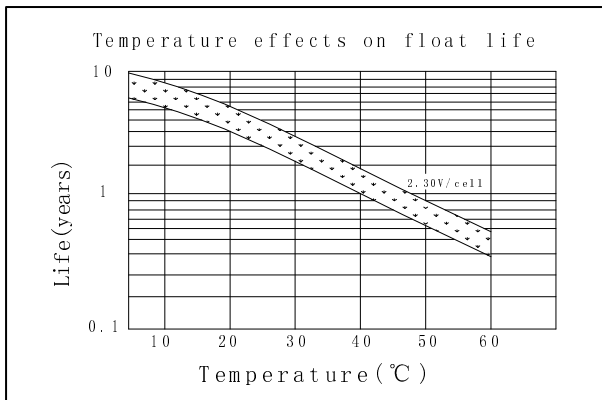
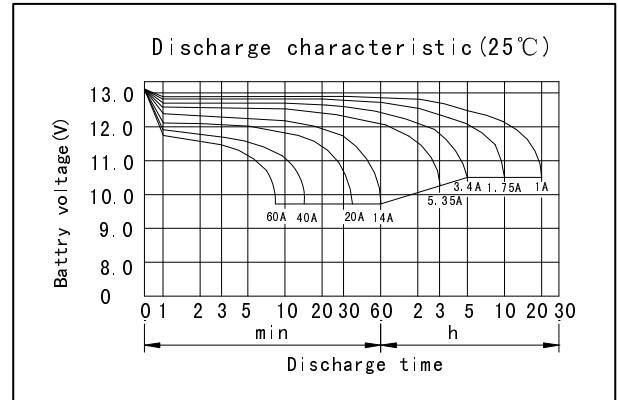
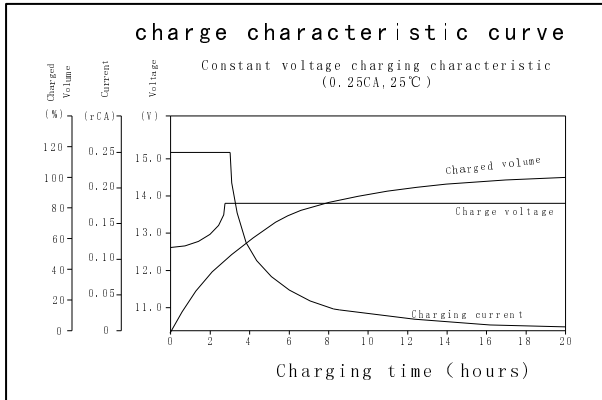

GREAT POWER BATTERY TECHNOLOGY CO.,LTD
 Address: Longguan 1st Road, Longhua Town, BaoAn District, Shenzhen, China.
 TEL: 86-755-2900 8403 Fax: 86-755-3386 3366
 Email: info@greatpowerbattery.com Http:// www.greatpowerbattery.com