

Leading the Industry in Solar Microinverter Technology

QS1

- Single unit connects to up to four solar modules
- Four input channels with independent MPPT and monitoring function
- Maximum continuous output power up to 1200VA
- CA Rule 21 (UL 1741 SA) compliant
- Accommodates 60-cell / 120 split-cell and 72-cell / 144 split-cell PV modules, including bi-facial, up to 525W+

DIMENSIONS

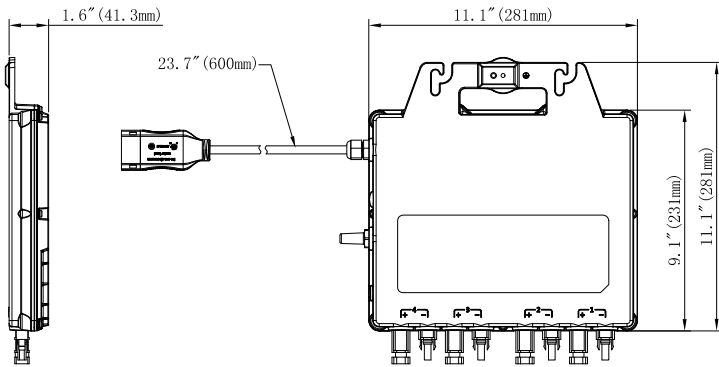

The APsystems QS1 is a grid-tied microinverter with Reactive Power Control (RPC) technology and Rule 21 grid support functionality. The QS1 provides high efficiency and high reliability with four independent MPPT inputs, and a Maximum AC output power of 1200VA.

Installation is 300% faster than conventional microinverters thanks to the QS1's ability to serve up to 4 PV modules, providing real cost savings for residential and commercial solar installers.

WIRING SCHEMATIC

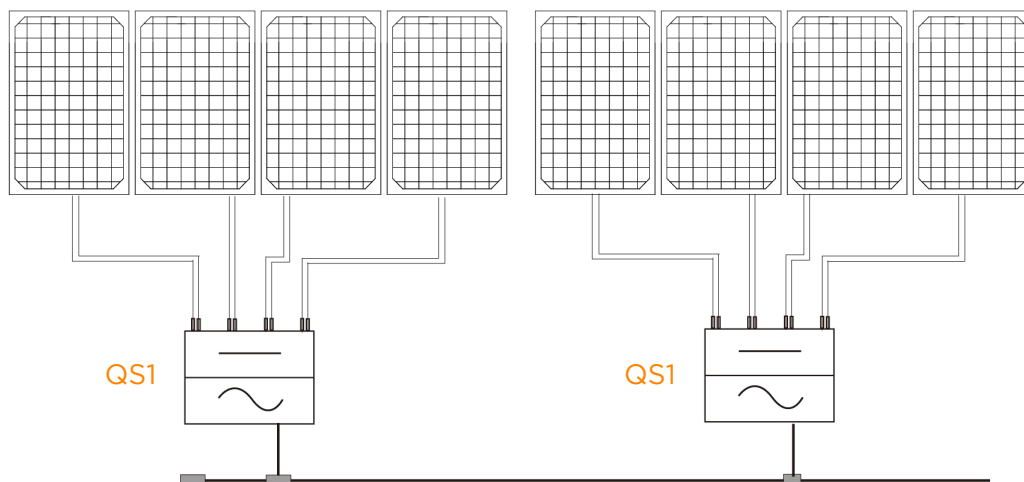

QS1 Microinverter Datasheet

Region

USA / Canada

Input Data (DC)

Recommended PV Module Power (STC) Range	250Wp-525Wp+	
PV Module compatibility	60-cell / 120 split-cell and 72-cell / 144 split-cell PV modules, including bi-facial	
MPPT Voltage Range	22V-48V	
Operation Voltage Range	16V-55V	
Maximum Input Voltage	60V	
Startup Voltage	20V	
Maximum Input Current	14A×4	
Maximum DC short circuit current	16A×4	

Output Data (AC)

	240V	208V
Maximum Continuous Output Power	1200VA	
Nominal Output Voltage /Range	240V/211V-264V	208V/183V-229V
Adjustable Output Voltage Range	150V-280V	
Nominal Output Current	5A	5.77A
Maximum Units Per Branch (16A max on 20A bkr)	3 units per 20A AC breaker (5A x 3 = 15A)	2 units per 20A AC breaker (5.77A x 2 = 11.54A)
Nominal Output Frequency/Range	60Hz/59.3Hz-60.5Hz	
Adjustable Output Frequency Range	55Hz-65Hz	
Output Power Factor Rating	>0.99(-0.8-0.8 adjustable)	
Total Harmonic Distortion	<3%	
Maximum Output Fault Current (AC) And Duration	137 Apk, 0.78 ms of duration	

Efficiency

Peak Efficiency	96.5%
Nominal MPPT Efficiency	99.5%
Night Power Consumption	30mW

Mechanical Data

Operating Ambient Temperature Range	-40°F to +149°F(-40°C to +65°C)
Storage Temperature Range	-40°F to +185°F(-40°C to +85°C)
Dimensions (W x H x D)	11.1" x 9.1" x 1.6"(281mm x 231mm x 41.3mm)
Weight	9.9lbs(4.5kg)
AC Bus Cable	12AWG
Enclosure Rating	Type6
Cooling	Natural Convection - No Fans

Features

Communication	Zigbee Wireless, 2.4GHz
Transformer Design	High Frequency Transformers, Galvanically Isolated
Monitoring	Via EMA* Online Portal
Warranty	10 Years Standard ; 25 Years Optional

Certificate&Compliance

Compliance	UL-1741** / IEEE-1547, FCC Part 15 Class B, ICES-0003 Class B, CA Rule 21 (UL-1741-SA)**
NEC Compliance	NEC 2014, 2017 and 2020 690.12 for Rapid Shutdown / Module Level Shutdown, CAN / CSA-C22.2 NO. 107.1-16

* APsystems online Energy Management Analysis (EMA) platform

**Meets the standard requirements for Distributed Energy Resources (UL 1741, UL 1741-SA) and identified with the CSA Listed Mark



Specifications subject to change without notice - please ensure you are using the most recent update found at usa.APsystems.com or canada.APsystems.com.