

BlackDiamond™

MJE-B 275W

The Black Diamond 275W is a high-efficiency module with four busbar, monocrystalline cells. Designed for durability with a double coated, black anodized frame, the Black Diamond excels in any environment.



Modules are the heart of a PV system. Why take chances? Mitsubishi Electric, a diversified global Fortune 500 firm founded in 1921, manufactures panels that greatly exceed industry requirements. With 40+ years of PV experience, Mitsubishi has small and large installations around the globe, demonstrating the strength and resilience of the modules in a variety of environments. Mitsubishi modules, designed for reliability and durability, are manufactured in our own factories in Japan. With financial strength and unparalleled product quality, you can count on Mitsubishi Electric.

Technological Innovations

Our modules are designed for high-efficiency and high power output to utilize limited space while giving you greater return on investment. Each cell is matched for electrical uniformity to eliminate hotspots and improve reliability.

Enhanced Reliability

Engineering excellence and attention to the finest detail ensure longevity and optimal performance. Our corrosion-resistant design even allows installation next to saltwater.

Mitsubishi Electric Quality

Our experienced engineers and meticulous manufacturing processes provide the highest quality products possible. Automated production lines ensure consistent high quality in every cell and module, each flash tested to ensure rated level of output. Mitsubishi Electric modules are manufactured in Japan. Mitsubishi Electric uses 100% lead-free solder, a safer and more eco-friendly solution.

FEATURES

- 25** years Linear performance warranty
- 10** years Workmanship & materials warranty
- 0/+5%** Positive power tolerance
- 1000** volts Maximum system voltage
- Lead-free solder** Safer for the environment
- 97.1%** Excellent low light performance
- 2000** hours Accelerated aging test
2000 hours damp heat test
400 thermal cycles

Proprietary cell surface texturing process increases light absorption

Four busbar, monocrystalline cells increase module efficiency



Four-layer protective junction box reduces risk of failure from water or dust intrusion, enhancing reliability and safety

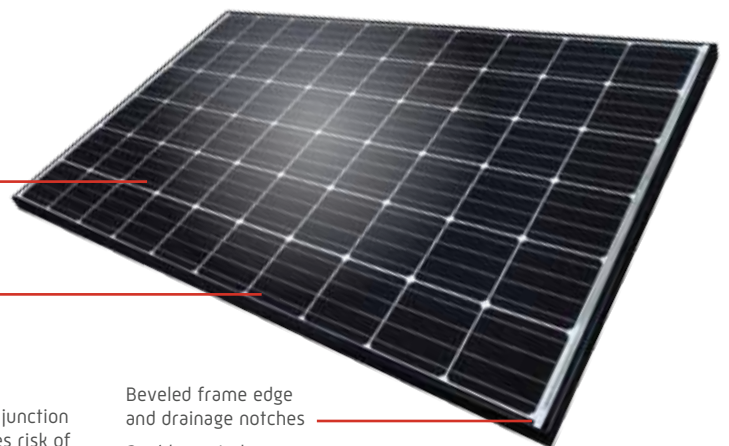

Beveled frame edge and drainage notches

Double coated, black anodized frame for greater corrosion resistance
Solid C-Channel frame



Module Specifications

Model name	PV-MJE275FB-B
Cell type	Monocrystalline Silicon, 156.75mm x 156.75mm
Number of cells	60 cells
Maximum power rating (Pmax)	275 W
Warranted minimum Pmax	275 W
PV USA test condition rating (PTC)	247.6 Wp
Open circuit voltage (Voc)	38.3V
Short circuit current (Isc)	9.36A
Maximum power voltage (Vmp)	31.3V
Maximum power current (Imp)	8.79A
Module efficiency	16.7%
Aperture efficiency	18.8%
Tolerance of maximum power rating	-0/+5%
Snow & Wind (UL1703 Test Load)	5,400 Pa
Number of bus bars per cell	4 Bus bars

Black Diamond™

Normal operating cell temperature (NOCT)	46.0°C
Maximum system voltage, DC	600V & 1000V (UL), 1000V (IEC)
Fuse rating	15A
Dimensions	65.2 x 39.1 x 1.81 inch (1657 x 994 x 46 mm)
Weight	41.8 lbs (19 kg)
Number of modules per pallet	22
Number of modules per container (40 ft. container)	616
Output terminal	SMK (PV-03) connector
Output cable, (+) & (-)	46.3 inches (1175 mm)
Certifications	UL 1703, IEC 61215 2nd Edition, IEC 61730
Fire rating	Type 2, 5, 8
Country of Origin	Made in Japan



Drawings and Dimensions Unit: inch (mm)

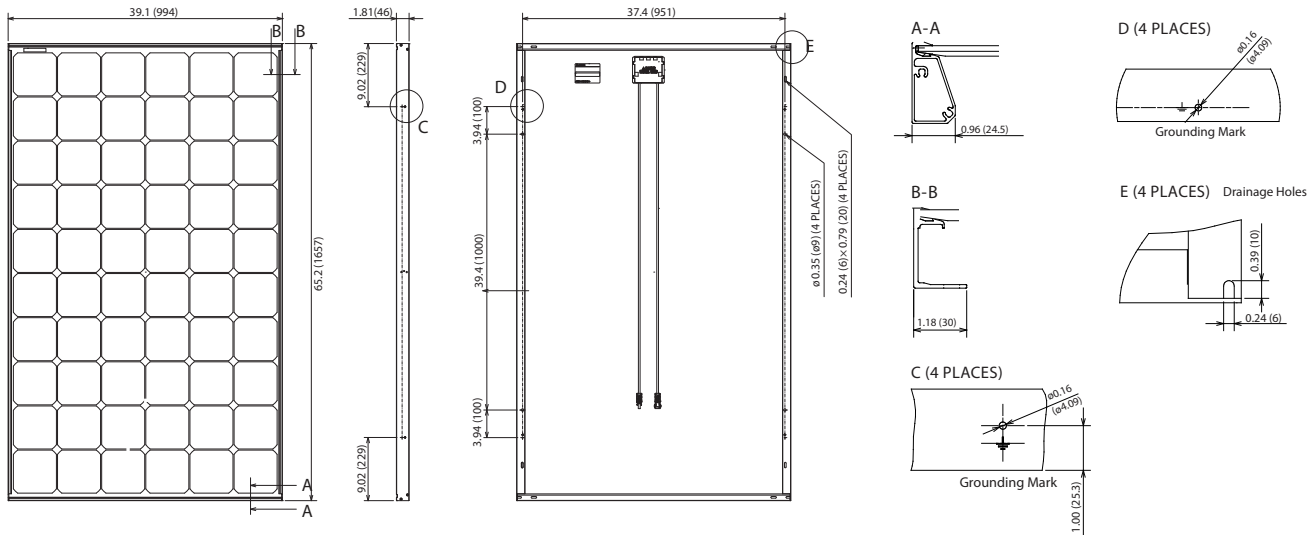

Electrical Characteristics

Electrical Performance

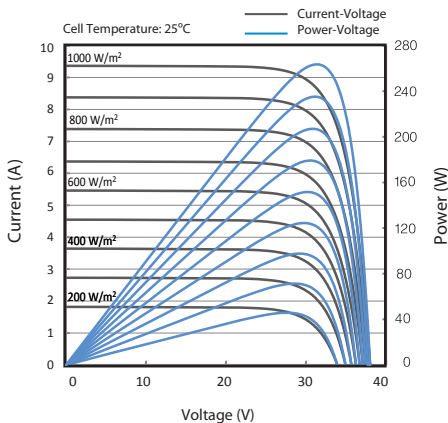

Temperature dependence of Isc, Voc and Pmax

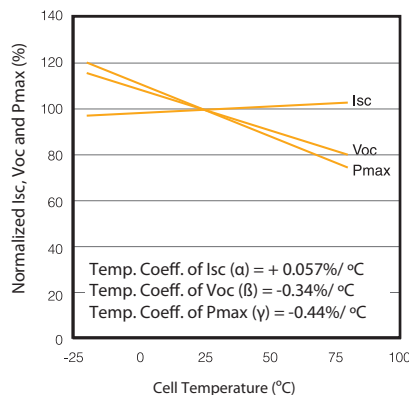

Irradiance dependence of Isc, Voc and Pmax

