



SOLAR PANELS PLUS

Top-of-Pole Mounts

Single Pole PV Mounting System



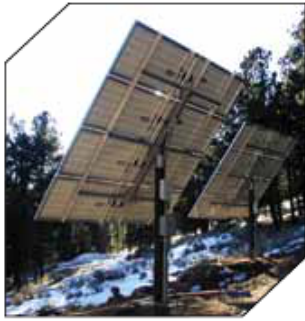

Top-of-Pole PV Mounting System

The POWER-FAB TPM is designed to install quickly and provide a secure mounting structure for PV modules on a single pole. The module specific design reduces the number of components and provides for an easier assembly. The TPM utilizes high strength welded steel components and corrosion resistant hardware for long term reliability. Seasonal adjustability for maximizing production is provided by six different tilt-angle settings and is a single person operation.

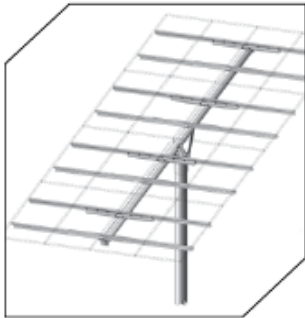

Maximum Strength – Durable Design

- Standard mounts designed to withstand 90 MPH wind zones
- MIG welded steel strong backs and mounting sleeves
- Two coats of industrial urethane enamel paint
- 6000 series structural Aluminum mounting rails
- Stainless Steel module mounting hardware
- Zinc plated rack assembly hardware

Application Flexibility

- Several sizes available from 1 through 24 modules
- Installs over standard Schedule 40 or 80 rigid steel pipe (Installer Supplied)
- 15° to 65° tilt angle settings (10° increments)
- Mount up to 4.1kW on a single pole

Ease of Assembly – Reduced Labor Costs

- Module Specific design reduces number of parts
- No measuring required
- Array tilts flat for easy module placement
- Factory set module hole placement locations create uniform spacing
- Easy access bottom flange bolting

Key Benefits

- Maximum Strength
- Module Specific Design
- Ease of Assembly – Reduced Parts
- Single Ground Penetration
- Seasonal Elevation Adjustment

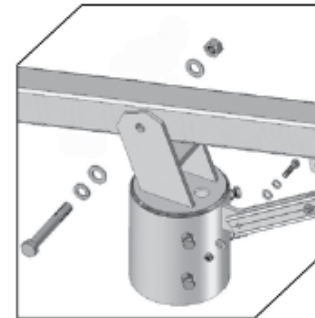

Ordering Guideline

TPM8-D-SHARP-NE170UC1-HWV-AA

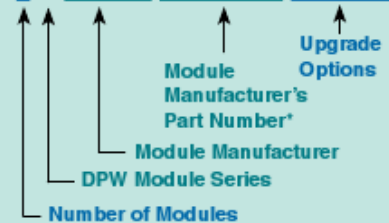

*Important: Include complete module part # as listed on module manufacturer's specification sheet

Options / Upgrades

- High Wind Version – 130 MPH Exposure C
- Hot Dip Galvanized or Powder Coated Finish on steel components
- Anodized Module rails
- Stainless Steel Rack Assembly Hardware Package
- Tamper-Resistant Module Mounting Hardware Package



(866) 579-5277

(757) 549-1494

www.solarpanelsplus.com

info@solarpanelsplus.com

Foundation Design Support available from DPW Solar's staff of engineers.