

VENSYS SOLAR TECHNOLOGY

VENCON 1500 Solar Inverter - efficient and profitable



VENSYS Quality >Made in Germany<

Our reliable and trustworthy systems minimise the risk and increase the benefits for customers and partners thanks to a 100 percent commitment research, development, safety and quality standards.

Safety and quality deserve top priority. Hence, only technologies from carefully selected suppliers are used in all our products. Each of our products has passed extensive testing in our own laboratory facilities to meet our high safety and quality standards.





VENCON 1500 **Applications**

VENCON PV-Inverters increase the overall efficiency and reliability of your solar park. The VENCON Series provides a profitable way to convert the direct current, generated by the solar modules, into valuable and CO₂-free alternating current and feed it into the grid.

Years of experience and a proven technology platform have been re-combined to develop the VENCON 1500. With its high range from 100 kW to 1500 kW, the VENCON 1500 is designed to be the ideal solution for large scale applications such as solar power plants and industrial buildings.

Maximum yield

The VENCON inverter is characterized by its high efficiency rate ensuring that the generated energy is fed into the grid with minimal loss. Here, the precise and optimal system control and in-house MPP tracking (maximum powerpoint tracking) are unique attributes to the VENCON 1500.

Compact and modular design

The compact design stands for low system costs, easy maintenance and quick installation. Thanks to the modular system design, VENCON PV-Inverters can be configured and delivered according to customer requirements at short notice. The optimized 'Plug & Power Container Solution' is available for outdoor use.

Conformity

The VENCON Series offers extensive compliance with all local network connection standards. These can be adapted to individual country supply requirements.

Application

The VENCON Series offers the possibility to integrate an energy storage system such as the 'VENSYS VENSTORE Lion' into the entire system.

VENSYS String Combiner

The VENSYS String Combiner ensures that all strings in the solar field are collected intelligently and safely and offers ideal monitoring capabilities. They guarantee a harmonious interplay with the VENCON Series resulting in significant reduction in errors and correspondingly an increase in efficiency.

Service and support

The worldwide VENSYS Service Network supports our customers and partners on a wide range of activities. Starting with preventive Due-Diligence measures through installation and commissioning all the way to spare part supplies and repairs. Options to extend warranties as well as different service packages provide the necessary flexibility.

VENSYS SOLAR TECHNOLOGY

VENCON 1500

VENSYS-Quality guarantees reliability



Solar Power
Plants



On-Grid
Commercial /
Industrial
Systems

HIGHLIGHTS

- High efficiency rate and optimized MPP tracking
- Proven design with more than 15 GW of installed power
- Best grid compatibility: All grid codes
- Usage of multiple energy sources possible (Solar and VENSTORE battery storage)
- First-class safety standards thanks to protective devices and precise monitoring
- Innovative cooling system with extended temperature range
- Minimized electromagnetic interference due to symmetrically grounded intermediate circuit
- Free of voltage-induced degradation (PID)



DESIGN

VENCON solar inverters stand for efficiency, safety and low system complexity. This results in great profitability by means of maximum yields at low costs.

The VENCON 1500 offers a performance range from 100 kW to 1500 kW and achieves an excellent efficiency rate of 98.7 % on the inverter side. Integrated DC-/ DC-boost-converters increase the voltage range and allow the connection of different module types. Installed LC-filters help to avoid increased ripple currents caused by the solar modules.

The built-in VENSYS Cooling System guarantees a safe operation at full nominal power for ambient temperatures from -20 °C to +45 °C, thus enables a flexible application in different climatic zones.

The VENCON 1500 complies with VENSYS' global security and connectivity standards. Thanks to extensive protection devices on the DC and AC side, such as fuses, overvoltage protection and filters. The VENCON inverter achieves a remarkably high degree of reliability and safety. Remote maintenance as well as the connection to common data collection systems are also possible, even by smartphone.

Available Options:

- Outdoor 'Plug & Power Container Solution'
- Complete version incl. VENSYS String Combiner
- DC grounding (negative or positive)
- Fieldbus, Ethernet or Profinet connection
- Extended warranty and separate service agreements including monitoring

TECHNICAL DATA

VENCON 1500

GENERAL

1. Version	Indoor / Container solution
2. Inverter type	1.5 MW Inverter Solar/Storage
3. Principle	IGBT inverter
4. IGBT type	SKiiP 3-technology
5. Supply voltage (AC)	400 V AC, 3-phases
6. Total weight	2,300 kg / 9,500 kg
7. Dimensions Indoor / Container solution (WxDxH)	2,600 x 826 x 2,080 mm / 6,058 x 2,438 x 2,591 mm
8. Protection class	IP54

CONNECTIONS AC SECTION

1. Rated AC voltage	620 V, 3-phase-system
2. Type	Without transformer (IT / TN-grid)
3. Rated AC current	1397 A
4. Apparent power	1500 kVA
5. Rated power	1500 kW
6. DC-link voltage	± 575 V
7. IGBT switching frequency	2.4 kHz
8. Rated frequency (fr)	50 Hz
9. Frequency range	47.5 – 63 Hz
10. Adjustable displacement power factor (cos ϕ)	0.925 overexcited to 0.925 underexcited
11. THD at nominal load	THD ≤ 4.0 % (EN-50160, IEC61000-3-6)
12. Overcurrent protection (Imax)	1600 A

CONNECTIONS DC SECTION

1. Number of independent MPP inputs	1
2. Strings per MPP input	Max. 18
3. Short circuit protection	200 A gPV fuses
4. MPP voltage range	400 – 1000 V
5. Max. input current	2028 A (3 x 676 A)
6. Max. open-circuit voltage	1100 V

EFFICIENCY

1. Efficiency rate (EUR)	98.7 %*
2. Standby self-consumption	< 200 W

CONTROL

1. Main control system	WAGO fieldbus-controller
2. Power interface	WAGO MODBUS
3. External communication	TCP / IP

COOLING

1. Cooling system	VENSYS Water Cooling
2. Cooling principle	Water cooled
3. Working pressure (setpoint)	Approx. 2 bar
4. Refrigerant	Water – Ethanol mixture

ENVIRONMENT

1. Operating temperature range	-20.0 °C ... +45.0 °C (without derating)
2. Storage temperature range	-30.0 °C ... +60.0 °C
3. Max. relative humidity	95.00 % (not condensing)
4. Max. installation height (altitude)	< 1,500 m (above sea level)

SAFETY AND APPROVAL

1. Noise emission	Max. 75 dB
2. DC protection device	Switch-disconnector
3. Overvoltage protection category	Type 2
4. Lightning protection class	Optional
5. Overvoltage protection category (self-supply)	Typ 2
6. Compliance	EN 55011 / EN 55016 / IEC 60068 / IEC 61683 / IEC 61727
7. Certificates	BDEW / TC2007 / FGW TR3 / FGW TR4

* Efficiency rate measured without self-supply

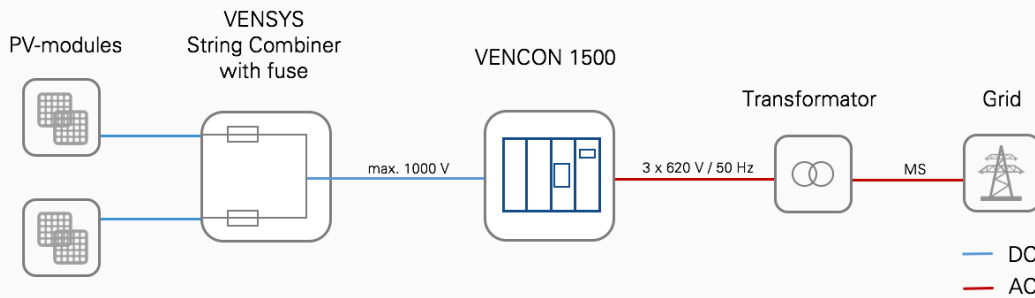
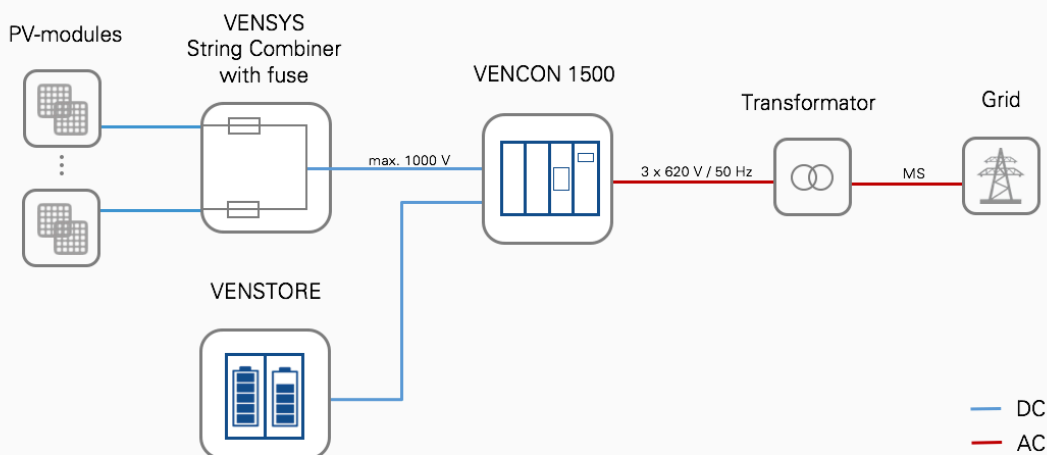
SYSTEM DIAGRAM
SOLAR
VENCON 1500

SYSTEM DIAGRAM
SOLAR and STORAGE
VENCON 1500

VERSION: 1.3
 DATE: June/2017

CONTACT

VENSYS Elektrotechnik GmbH • Dieselstraße 12 • 49356 Diepholz • Germany
 Tel.: +49 5441 92630-0 • Fax: +49 5441 92630-11
 Mail: sales@vensys-elektrotechnik.de