

Centralized Three-phase PV inverter

SPI500K-B/SPI630K-B/SPI1000K-B/SPI1260K-B



Product Features

High efficiency

- Advanced three-level topology, maximum conversion efficiency 99%
- 45°C 1.1 times long-term overload, 50°C full load operation

Safe and reliable

- Adapt to high altitude, high temperature, extreme cold and other complex environment
- Intelligent fan speed control and fault detection, improve system reliability
- PID repair function to ensure power generation

Lean intelligence

- Intelligent fault recording function, quick failure analysis
- Intelligent online upgrade function, easy system upgrade and maintenance management

Cost saving

- High power density in 0.6m², reducing system land cost
- Turnkey products, easy to install and debug on site (container)
- Support AC side parallel at transformer primary side
- Modular design, saving operation and maintenance cost

Function Diagram

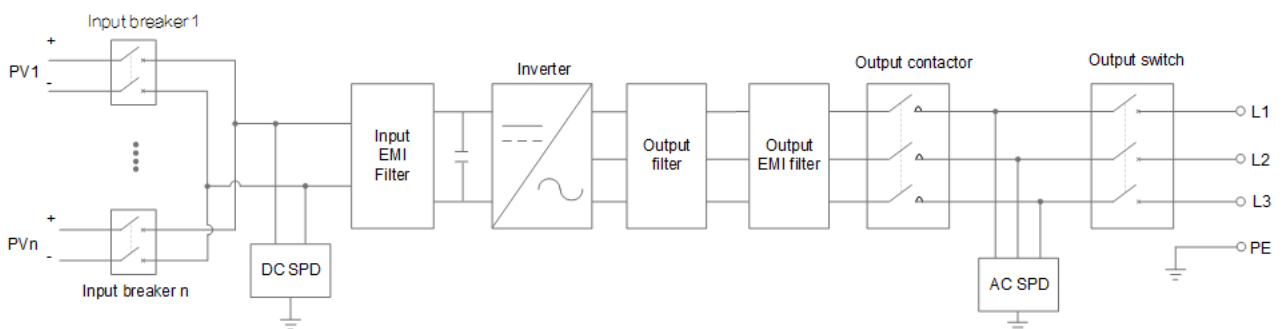

Technical Specification

Items	SPI500K-B	SPI630K-B	SPI1000K-B	SPI1260K-B
DC input				
Max. input power	560kW	710kW	2×560kW	2×710kW
Max. input voltage	1000Vdc			
Max. input current	1200A	1350A	2×1200A	2×1350A
No.of PV input strings	6	8	2×6	2×8
No.of MPPTs	1		2	
MPPT voltage range	460Vdc~850Vdc	520Vdc~850Vdc	460Vdc~850Vdc	520Vdc~850Vdc
Start-up voltage	480Vdc	540Vdc	480Vdc	540Vdc
MPPT Efficiency	99.90%			
AC output				
Rated AC output power	500kW	630kW	1000kW	1350kW
Max. output power	550kW	693kW	1100kW	1386kW
Max. output current	1008A	1111A	2016A	2222A
Rated AC output voltage	315Vac	360Vac	315Vac	360Vac
Rated frequency	50Hz/60Hz			
Power factor	>0.99			
Adjustable power factor	0.9 (leading)~0.9 (lagging)			
THDi	<3% (nominal power)			
Efficiency				
Max. efficiency	99.00%			
European efficiency	98.70%			
Others				
LVRT function	Yes			
AC side parallel technology	Yes			
Anti-PID function	Optional			
Fault wave record diagnosis	Yes			
Online upgrade	Yes			
System data				
Dimensions (WxHxD)	800×2000×800mm		2438×2591×1150mm	
Weight	700kg		2800kg	
IP grade	IP20			
Night power consumption	<20W		<40W	
Cooling type	Intelligent forced air cooling			
Altitude	6000m (>3000m derating)			
Operating temperature	-35°C~60°C			
Relative humidity	0~95% (no condensation)			
Display	LCD			
Communication	RS485, Ethernet (optional)			

■ Specifications are subject to change without prior notice.