

Monofacial

G1 SERIES

Monocrystalline Silicon PV Modules 315-335 Watt



Positive Tolerance 0~+5W



Enhanced Product Warranty
on Materials and Workmanship



Linear Power Performance Warranty

KEY FEATURES



MULTI BUSBAR TECHNOLOGY

Better light trapping and current collection to improve power and reliability.



REDUCED HOT SPOT LOSS

Optimized electrical design and lower operating current for reduced hot spot loss and better temperature coefficient.



PID RESISTANCE

Excellent Anti-PID performance guarantee via production and materials control.



RELIABLE PERFORMANCE

Durability against salt mist and ammonia environmental conditions.

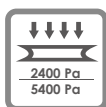

STABLE MECHANICAL PERFORMANCE

Withstands 5400Pa snow loads and 2400Pa wind loads.



Monocrystalline Silicon PV Modules 315-335W

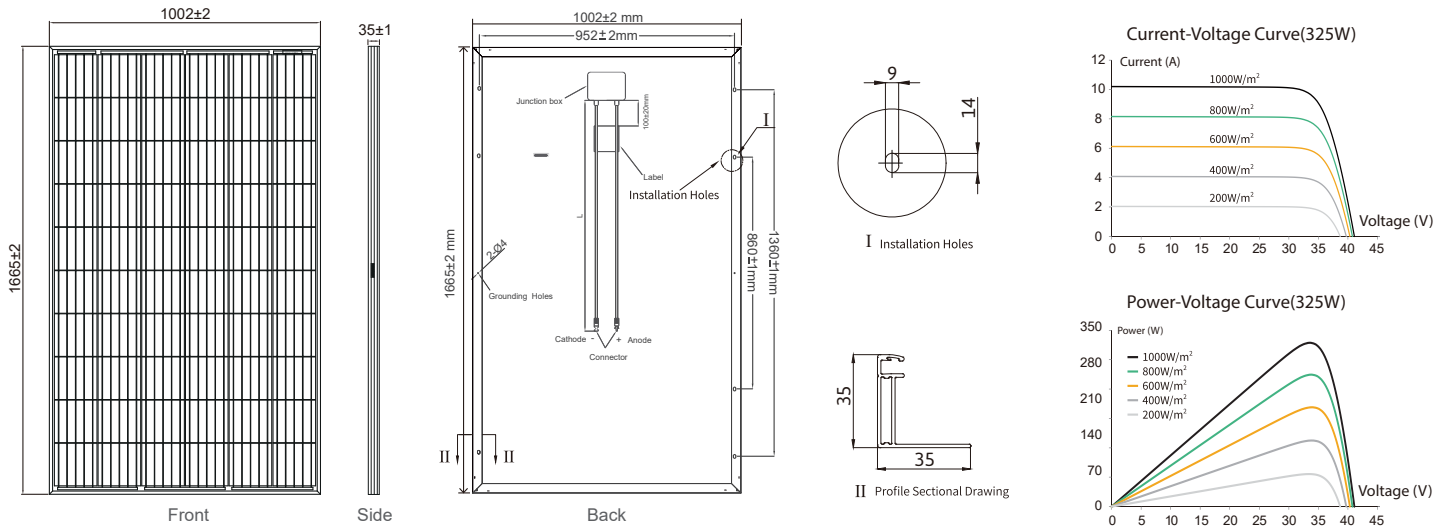

Additional Value

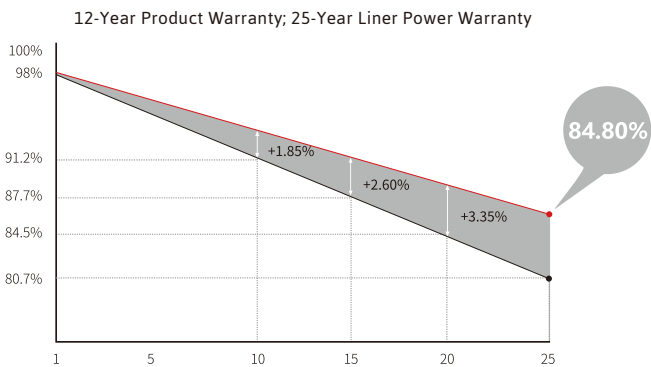

Mechanical Parameters

Cell Type	Mono PERC 158.75×158.75mm
Cell Orientation	60 Cells (6×10)
Junction Box	Protection class IP68
Output Cable	TÜV 1×4.0mm², Length 900mm; wire length can be customized
Glass	3.2mm coated tempered glass
Frame	Anodized aluminum alloy frame
Weight	19.0kg
Dimension	1665×1002×35mm
Packaging	30pcs per pallet / 840pcs per 40'HQ

Electrical Characteristics

Module Type	DC315M-60		DC320M-60		DC325M-60		DC330M-60		DC335M-60	
	STC	NOCT	STC	NOCT	STC	NOCT	STC	NOCT	STC	NOCT
Testing Condition	STC	NOCT	STC	NOCT	STC	NOCT	STC	NOCT	STC	NOCT
Maximum Power (Pmax/W)	315	235	320	239	325	242	330	246	335	250
Voltage at Max. Power (Vmp/V)	33.2	31.2	33.4	31.4	33.6	31.6	33.8	31.8	34.0	32.0
Current at Max. Power (Imp/A)	9.49	7.56	9.59	7.62	9.68	7.66	9.77	7.74	9.87	7.82
Open Circuit Voltage (Voc/V)	40.7	37.6	40.9	37.8	41.1	38.0	41.3	38.2	41.5	38.4
Short Circuit Current (Isc/A)	10.04	8.33	10.15	8.44	10.20	8.54	10.31	8.65	10.36	8.74
Module Efficiency (%)	18.88		19.18		19.48		19.78		20.08	

STC (Standard Testing Conditions): Irradiance 1000W/m², Cell Temperature 25°C, AM1.5.

NOCT (Nominal Operating Cell Temperature): Irradiance 800W/m², Ambient Temperature 20°C, AM1.5, Wind Speed 1m/s.

Operating Parameters

Operating Temperature	-40 °C ~+85 °C
Power Output Tolerance	0 ~ + 5W
Voc and Isc Tolerance	±3%
Maximum System Voltage	1000/1500V
Maximum Series Fuse Rating	20A
NOCT (Nominal Operating Cell Temperature)	45±2 °C
Protection Class	Class II
Fire Rating	UL type 1 or 2

Mechanical Loading

Front Side Maximum Static Loading	5400Pa
Rear Side Maximum Static Loading	2400Pa
Hailstone Test	25mm Hailstone at the speed of 23m/s

Temperature Ratings(STC)

Temperature Coefficient (Pm)	-0.370% °C
Temperature Coefficient (Voc)	-0.280% °C
Temperature Coefficient (Isc)	0.048% °C



No.19 Fushun Branch Road, Qingdao,
Shandong, China 266000
Web: www.hinergy.net
Email: info@hinergy.net

Due to continuous innovation, R & D and product improvement, Hinergy has the right to adjust the specs on this datasheet at any time without prior notice.