

USER MANUAL

LCWS-A1

Intelligent Boost Wind Solar Hybrid



Caution

1. Thank you for purchasing our controller. Before you install and use the product, please carefully read the User's Manual and properly keep it.
2. The controller shall be installed by an experienced technician in strict accordance with the User's Manual, to guarantee that it can work normally.
3. Keep the product free of contact with corrosive gas and humid environment for a long time.
4. Be sure not to place the product at a place where it is exposed to humidity, rain, sun, severe dust, vibration, corrosion, or strong electromagnetic interference.
5. Please don't open the product's casing to repair it by yourself.

Table of Contents

I. Product Overview	1
II. Description of Model	2
III. Installation Specification.....	3
IV. LCD Operation and Display Instructions.....	4
4.1 Description of keys	4
4.2 Description of display content.....	5
4.3 Day and night identification	7
4.4 Output mode	7
4.5 Instructions for control panel.....	7
V. Protection Mechanism	13
VI. Performance Parameters	14
VII. Common Faults and Troubleshooting	14
VIII. Warranty and After-sale Service	155

I Product Overview

This controller is specially designed for high-end small wind-solar hybrid systems and applies to wind-solar hybrid street lighting systems and wind-solar hybrid monitoring systems. Its main functions are shown as below:

- 1) This controller, being a high-performance wind-solar hybrid controller, can control wind generators and solar cells to charge or discharge the storage batteries at the same time; when charging, it adopts high-resolution PWM mode to charge the storage batteries via voltage and current limiting, which can effectively prolong the storage batteries' service life;
- 2) The controller is provided with an accurate rotating speed measuring and controlling module, so it can check the wind generator rotating speed in real time, and also can realize over-speed brake according to the set upper limit of safe rotating speed.
- 3) The controller is provided with two-channel DC output interfaces, and each channel has a maximum output current 10A; for each channel, the user can independently set three kinds of different output modes, namely, light-controlled on/off, light-controlled on/time-controlled off, and normally open.
- 4) The controller is provided with MPPT (maximum power point tracking) function. It, via advanced algorithm, can automatically search the maximum power point to realize the maximum conversion from wind energy to electrical energy. Through test, compared with traditional controllers, this controller can improve the charging efficiency by more than two times at maximum.
- 5) The controller is provided with a customized LCD, so the user can easily check and set the status of controller via the human-computer interaction interface:

The items which can be checked: storage battery voltage, wind generator rotating speed, wind generator voltage, wind generator current, wind generator power, photocell voltage, photocell current, photocell power, the first channel output mode, the first channel output turn-off time, the second channel output mode, the second channel output turn-off time, light-controlled on voltage point, light-controlled off voltage point, daytime or nighttime indicator, storage battery status, load status, as well as the status of faults like over-voltage, under-voltage, over-load, and short-circuit.

The items which can be set: the first channel output mode, the first channel output turn-off time, the second channel output mode, the second channel output turn-off time, light-controlled on voltage point, and light-controlled off voltage point.

- 6) The controller is provided with a unique solar charging circuit, with a small loss and heat, which is of open-circuit unloading mode, so as to effectively prolong the solar cell's service life.

- 7) Complete safety protection functions, including:

- ◆ solar cell reverse charging prevention protection
- ◆ solar cell reverse connection prevention protection
- ◆ solar cell current-limiting protection

- ◆ storage battery over-charging, over-discharging protection
- ◆ storage battery open-circuit protection
- ◆ storage battery reverse connection prevention protection
- ◆ overload, short-circuit protection
- ◆ lightning protection
- ◆ wind generator current-limiting protection
- ◆ wind generator over-speed protection
- ◆ automatic and manual brake protection of wind generator
- ◆ controller temperature monitoring, over-heat protection
- ◆ load over-voltage protection

※*Note: Except for storage battery reverse connection prevention protection, other protections above won't damage the components.*

8) The controller casing made of high-quality aluminum alloy is well designed, and has an attractive appearance and a good heat dissipation performance.

9) The controller is manufactured with strict production process and high-quality industrial components, so it can run reliably for a long time under cold, high-temperature, or humid environment.

II 、 Description of Model

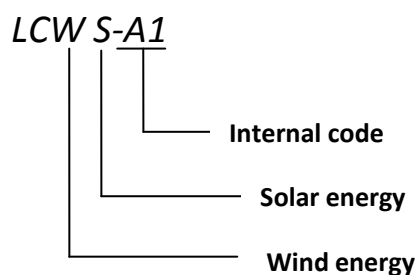

※*Note: Refer to VI Performance Parameters for detailed information*

III、 Installation Specification

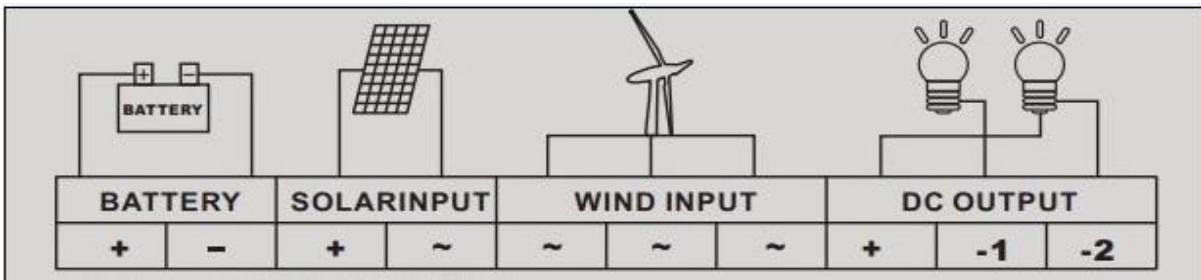

Output terminal connection diagram of LCWS-A1 wind-solar hybrid controller with double-channel standard configuration

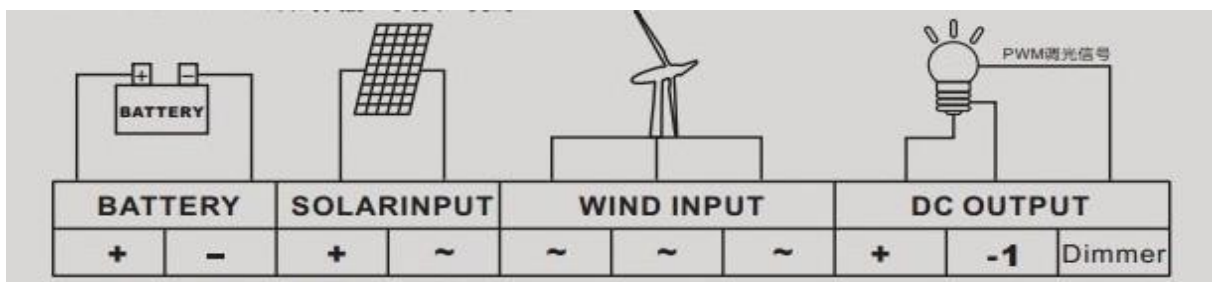

Output terminal connection diagram of LCWS-A1 wind-solar hybrid controller with single-channel dimming signal (optional)

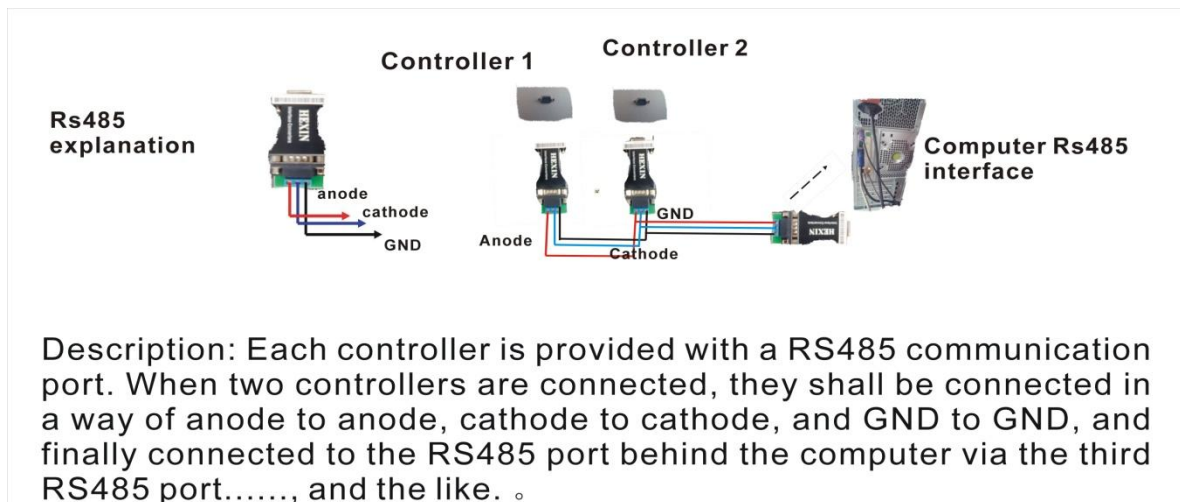

Connection diagram of LCWS-A1 wind-solar hybrid controller with communication port RS 485 (optional)

	<p><i>Dimmer port and communication port RS485 are optional, so the customer shall clearly specify what you need; otherwise we will deliver the one in standard configuration.</i></p>
---	--

After the parts of wind-solar hybrid generator system and photovoltaic panel are installed and external circuit construction is completed, it is required to connect and operate the system parts safely and reliably according to the following sequence.

- 1) Open the package to confirm that the equipment is not damaged in transportation.
- 2) Connect the DC load to *DC OUTPUT* terminal. The loads of two channels share the same anode. Connect the first-channel load to “+” and “-1” of *DC OUTPUT*, and the second-channel load to “+” and “-2” of *DC OUTPUT*.
- 3) Connect the storage battery to the *BATTERY* terminal of back panel of equipment with the cable with copper conductor of 6mm² and above.

	A reverse connection between anode and cathode of the storage batteries is forbidden, in order to avoid damaging components.
---	--



- 4) When wind generator is under static or low-speed running status (no wind), connect the wind generator output line to the WIND INPUT terminal of back panel of equipment.
- 5) Shield and then connect the solar cell panel to the SOLAR INPUT terminal of back panel of equipment according to anode and cathode.
- 6) Set corresponding parameters to select the load output mode via the keys on the controller’s LCD.



IV. LCD Operation and Display Instructions



Diagram of panel keys







4.1 Description of keys

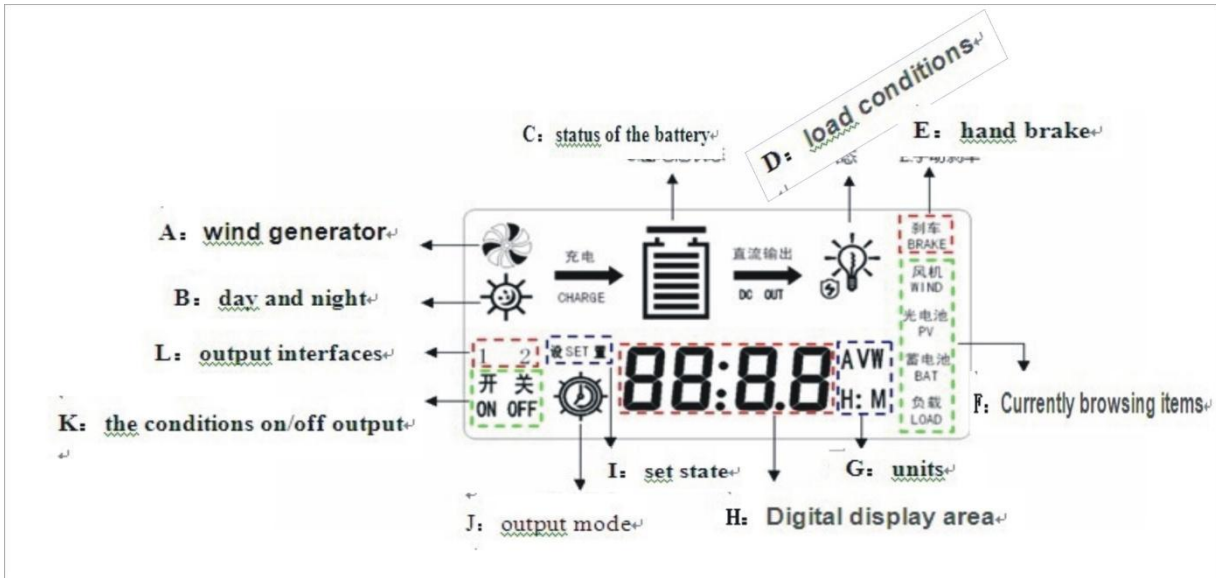









Symbol	Function description
	Add or display the next value: if under browsing status, press it to switch to next parameter display; if under setting status, press it to add the current parameter value modified.
	Reduce or display the previous value: if under browsing status, press it to switch to previous parameter display; if under setting status, press it to reduce the current parameter value modified.

	Setting/confirmation: if under browsing status, press it to enter the setting status; if under setting status, press it to store the parameters and return to the browsing status.
	Cancellation/manual switch: if under setting status, press it to return to the browsing status but not to store the values modified; if under browsing status, use it as a manual setting key in case of load short-circuit or over-load.

4.2 Description of display content



Serial No.	Symbol	Description	Notes
A		Indicating wind generator	
B		A symbol of sun, indicating daytime	
		A symbol of moon, indicating nighttime	
C		A symbol of storage battery, with the bars inside indicating the battery charge status	<p>When the battery is fully charged, 5 bars inside will all display ; when the storage battery is over-discharged, the symbol  will flicker and then stop flickering upon recovery from over-discharging status; when battery storage is under over-voltage status, a battery status indicator bar will appear, and the over-voltage symbol  will flicker and then stop flickering upon recovery</p>

			from over-voltage status.
D		Load status and fault status	Under a normal load, indicator lamp  will appear when without output, while indicator lamp  will appear when with output; under over-load status, load symbol  flicker, at this time, you need to eliminate the excessive load, and then press Esc key to recover the output; under short-circuit protection  , short-circuit symbol  will be on, at this time, you should check the load line and then press Esc key after confirmation for normality to manually recover it to original status.
E	(See Figure 4.2)	An icon of manual brake: when it is on, it indicates “under manual brake status”, otherwise “status of manual brake unlocked”.	
F	(See Figure 4.2)	An icon of the item browsed currently	
G	(See Figure 4.2)	Unit icons	A: current, unit: A; V: voltage, unit: V; W: power, unit: W; H: hour; M: minute.
H	(See Figure 4.2)	Digital display zone	
I	SET	Indicating “under setting status”	
J		A symbol of light & time control	 is a symbol of light & time control. When  appears, it indicates light-controlled on/off; and when  appears, it indicates light-controlled on / time-controlled off.
K	(See Figure 4.2)	Output on/off status	
L	(See Figure 4.2)	Two-channel load output interface	Channels 1 and 2

4.3 Day and night identification

It is night if the photocell voltage exceeds the light-controlled on voltage (can be set by users) for continuous 1min. It is day if the photocell voltage exceeds the light-controlled off voltage (can be set by users) for continuous 1min.

4.4 Output mode

Output mode	Specification
Normally open output mode	The voltage of battery is normal and within the rated load. The controller outputs will full power normally.
Light-controlled on/time-controlled off output mode	After dark (see 4.3 Day and night identification), it outputs according to the set load upper limit and the output off time is subject to the set time.
Light-controlled on/off output mode	After dark (see 4.3 Day and night identification), it outputs according to the set load upper limit and the output is off after the dawn).

4.5 Instructions for control panel

4.5.1 Start-up interface



In the start-up interface, 0.00V shows the current voltage of storage battery. Press  key to enter into wind generator parameter state, and the current rotate speed, voltage, current and power of wind can be viewed:

4.5.2 Wind generator operating parameter state:

4.5.2.1 View the current rotate speed of wind generator



0.00M in the picture shows the current actual rotate speed of wind generator. Press ▲ to enter into next parameter state, and the current voltage of wind generator can be viewed.

4.5.2.2 View the current voltage of wind generator

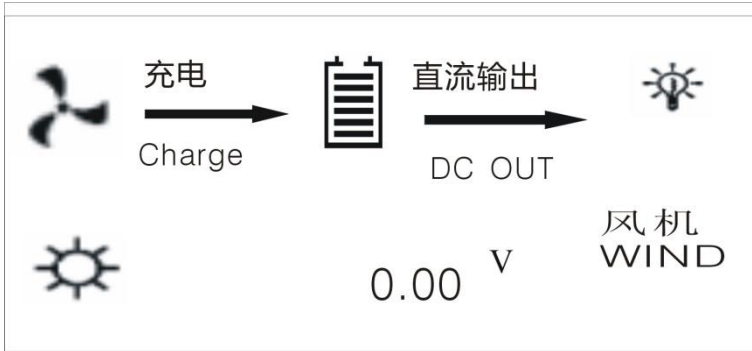

0.00V in the picture shows the current voltage of wind generator. Press ▲ to enter into next parameter state, and the current of wind generator can be viewed.

4.5.2.3 View the current of wind generator

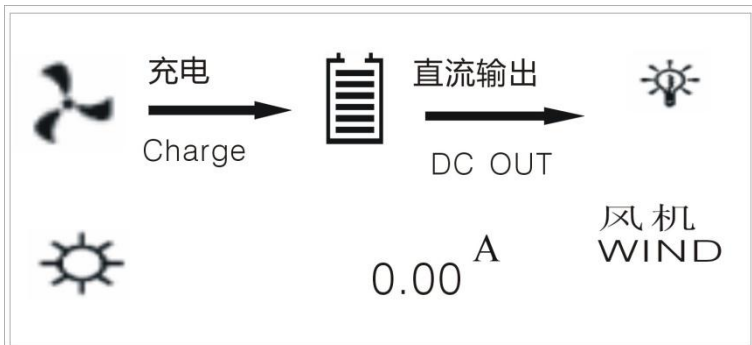

0.00A in the picture shows the current of wind generator. Press ▲ to enter into next parameter state, and the current power of wind generator can be viewed.

4.5.2.4 View the power of wind generator

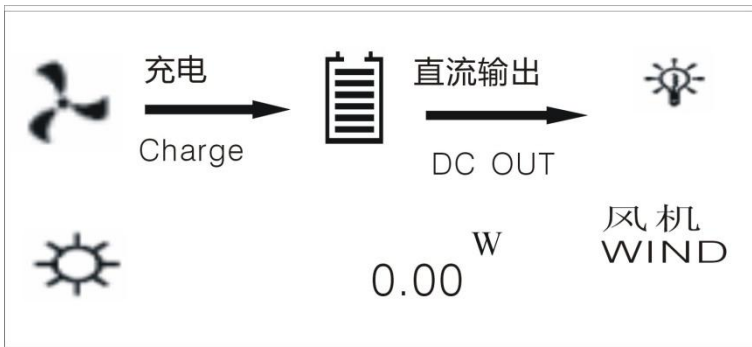

0.00W in the picture shows the current power of wind generator. Press ▲ solar PV parameter state, and the current voltage, current and power of solar PV can be viewed.

4.5.3 Operating parameter state of solar PV module

4.5.3.1 View the voltage of solar PV

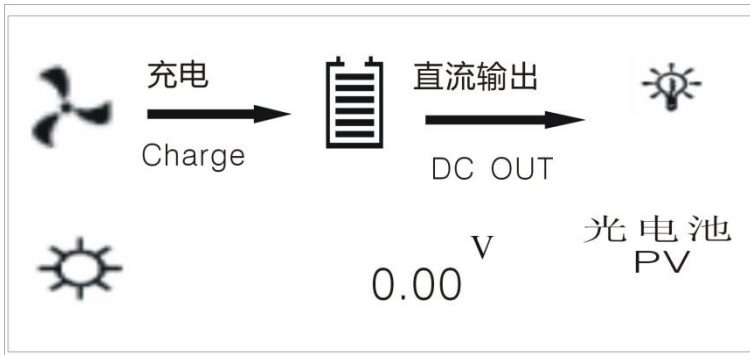

0.00V in the picture shows the current voltage of solar PV. Press ▲ to enter into the next parameter state, and the current of solar PV can be viewed.

4.5.3.2 View the current of solar PV

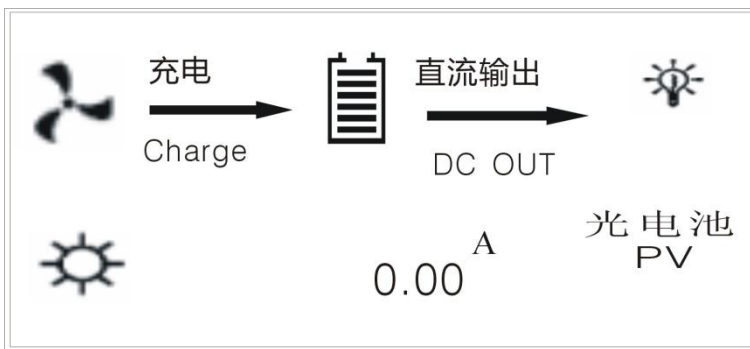

0.00A in the picture shows the current voltage of solar PV. Press ▲ to enter into the next parameter state, and the current power of solar PV can be viewed.

4.5.3.3 View the power of solar PV

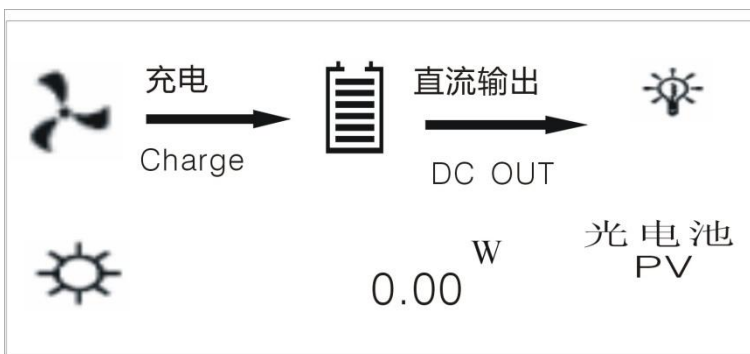



0.00W in the picture shows the current voltage of solar PV. Press ▲ to enter into D load parameter status, and the current of DC load can be viewed.

4.5.4 Operating parameter state of load

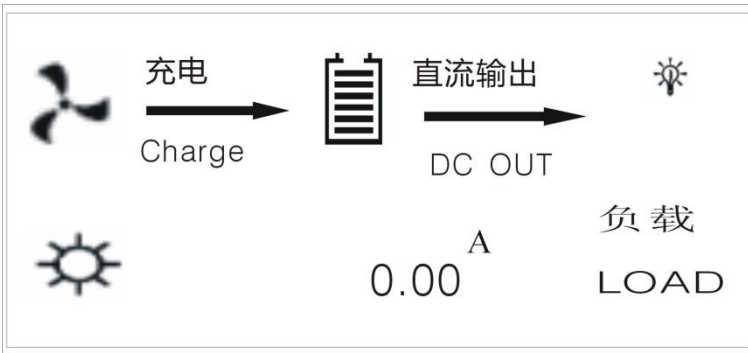
4.5.4.1 View the current of DC load



So far, the operating parameters of various parts of the system have been all viewed (if you need to look back certain parameter,  press to display parameters counter-cyclically); In this interface as shown in Fig. 4.5.4.1, press  to enter into output mode setting of Channel 1 and 2 DC load.



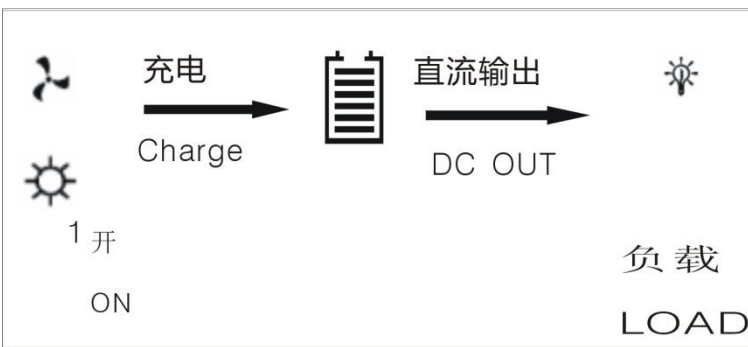



4.5.5 DC load output mode setting interface

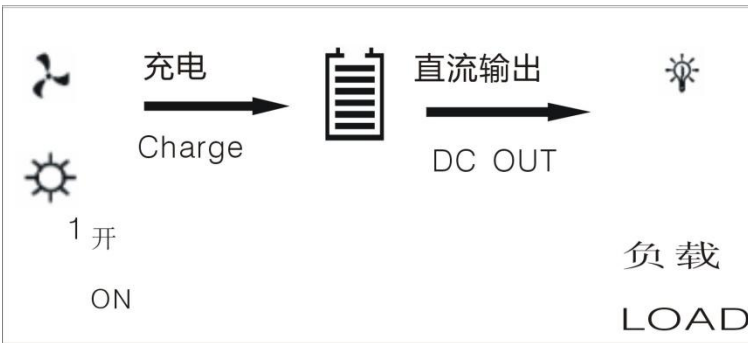

In this Manual, Channel 1 load is used as an example and its setting process is stated.

4.5.5.1 Normally open mode interface



In this interface as shown in Fig. 4.5.5.1, press  and the Channel 1 or 2 load setting interface can be switched over. For each channel, press  "set/confirm" key first and the screen will display a "SET" sign, and then press  or Channel 1  load can be switched over among the three output modes: normally open, light-controlled on/off, light-controlled on/time-controlled off. Users only need to select the mode they need, and then press  to confirm and press  ESC key to save and quit.

4.5.5.2 Output mode interface of light-controlled on/off

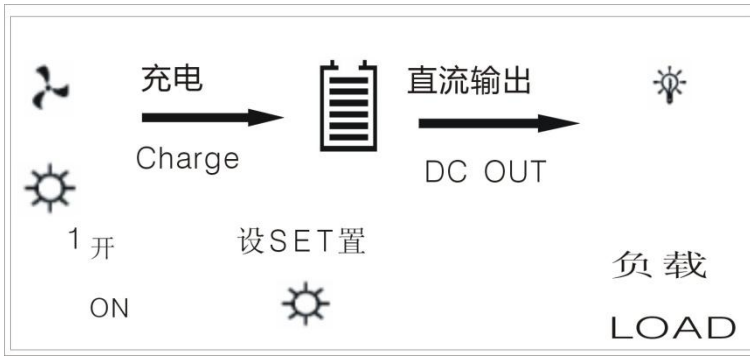

4.5.5.3 Output mode interface of light-controlled on/time-controlled off

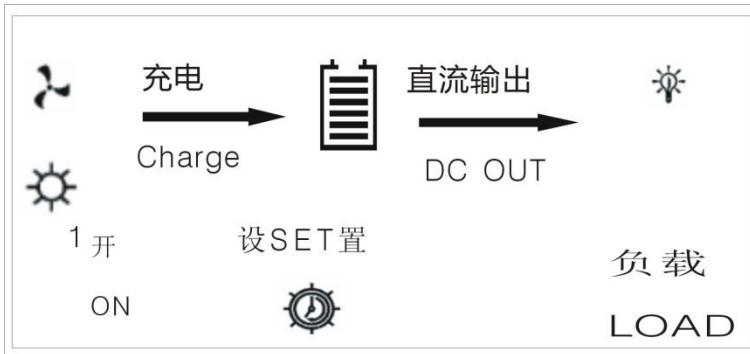



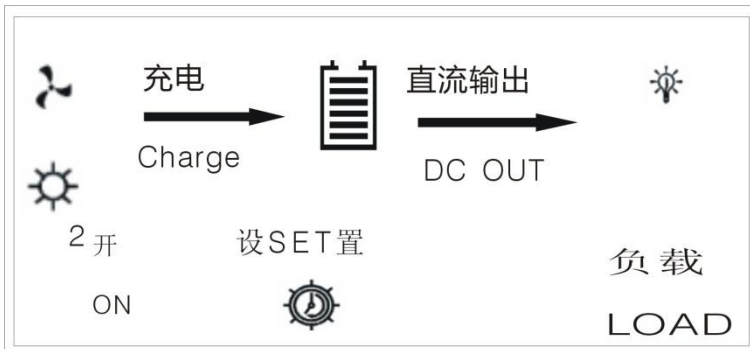

The output mode setting of Channel 2 is the same and its interface is as follows:

4.5.5.4 Output mode setting interface of Channel 2 load



4.5.6 Manual brake operation

To ensure the operation safety of wind generator and for the convenience of users, this controller is so designed that the wind generator can be braked manually under any state. The specific process: keep  "confirm" key on the panel pressed first, and then press ESC key  and hold for about 5min. Loosen the key to enter manual braking state, and there will be "Brake" displayed at the top right corner of the display interface. If you want to quit manual braking state, repeat the above operation, namely, keep  "confirm" key on the panel pressed first, and then press ESC key  and hold for about 5min. Loosen the key to quit manual braking state. "Brake" at the top right corner of the display interface will disappear. The specific interface is shown as follows:

1) Manual braking interface ("Brake" appears at the top right corner of the display interface)

It means the wind generator brake when brake appeared here



"Brake" appears, and the wind generator brakes

2) Quit manual braking ("Brake" at the top right corner of the display interface):

It means the wind generator quits braking when brake disappears here

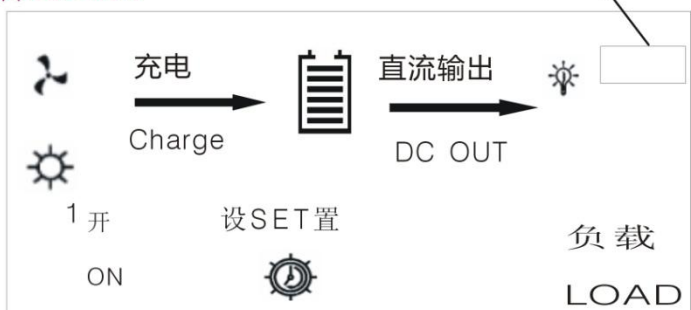

After wind generator brakes, it will stop rotating or rotate at a very slow speed. The wind generator is unable to generate electricity.

"Brake" disappears, and the wind generator quits braking state.

V. Protection Mechanism



Serial No.	Protection contents	Protection description	Remarks
1	General over-speed brake or brake off	If the rotate speed of wind generator exceeds the preset rotate speed of braking, it will automatically brakes through three-phase short circuit and the brake is off automatically after 3min.	The controller has automatic braking function
2	Over-speed brake or brake off under continuous strong wind	If there are more than successive 3 overspeed brakes within 30min, it will be determined as continuous strong wind and the brake can be off automatically only after 4h.	
3	Exceeding safe temperature	When it exceeds the safe temperature because of overhigh ambient temperature or overhigh temperature caused by heavy current, the system will enable over-temperate protection automatically, disable wind generator and photocell input, but the output will not be affected.	The controller has a built-in temperature testing module
4	Temperature decreases to safe temperature	Over-temperature protection is freed, and the system recovers to normal state.	
This controller has good heat dissipation measures and the over-temperature protection module will not be enabled under non-extreme cases.			

VI. Performance Parameters

Model	LCWS-A1	
System voltage	12V	24V
Turbine input voltage range	0 ~ 40V	0 ~ 40V
Turbine input current range (initial value)	0 ~ 15A(12A)	0 ~ 15A(12A)
Turbine maximum input power	300W	600W
PV input voltage range	0 ~ 25V	0 ~ 50V
Input current range (initial value)	0 ~ 30A(15A)	0 ~ 30A(15A)
PV maximum input power	500W	1000W
PV MPP	17 ~ 20V	34 ~ 40V
Number of output circuits	2-channel or 1-channel with dimming signal	
Output control mode	Always open; light-controlled; light on/time off	
Maximum output current of each loop	10A	10A
Static power	About 0.4W	About 0.8W
Communication interface	RS232 / RS485(optional)	
Operating temperature range	-20 ~ +50℃	
Operating humidity range	35% ~ 85% (no condensation)	
Product size	150*145*85.5mm	
Package size	188*182*130mm	
Weight	About 1.75Kg	

VII. Common Faults and Troubleshooting

If the above statements are not satisfied, or there is any abnormal phenomenon and the controller cannot return to normal, please contact the after-sale service or business personnel of our company for maintenance or replacement in a timely manner.

Phenomenon	Specification
Storage battery box  flickers and there is no output	It is over discharged. The storage battery is emptied. Please fully charge the storage battery before use.
Load icon  flickers and there is no output	The system detected output overload and will disable the overloaded output loop (the other loop will not be affected). Please check the loads, and remove the unnecessary or abnormal loads. Press Esc to recover.
 is on and there is no output	The system detected output short circuit and will disable the short circuited output loop (the other loop will not be affected). Please check the loads and connection lines. After troubleshooting, press Esc to recover.
The output is normal but it is not charged.	The temperature of the controller is too high and the over-temperature protection (the wind generator brakes, the photocell has open circuit, but the output will not be affected). When the temperature decreases to recovery temperature, the system will recover.

VIII. Warranty and After-sale Service

1. The product quality warranty of our company is one year, or in case of any defect or fault found within the quality warranty year as agreed in the contract; our company will provide free maintenance service. Please contact the after-sale department or related business personnel of our company.

2. The warranty range in this quality warranty clause is exclusive of damages caused by external factors, such as damages caused by force majeure, e.g. accident and natural calamities, use not in accordance with the product specification, improper use, negligence, refit, repair, improper installation, improper testing, improper transportation, etc.