



M6 | Bifacial 144 cells (Glass-T type)

Power Output (STC): **450 - 470 Watt**
Max. Efficiency (STC): **21.62%**



High Mechanical Load
Certified to withstand high wind and snow loads up to 5400Pa



Enhanced Performances
Bifacial feature allows a power boost up to 20% vs monofacial



Lower LCOE
Higher power output over the long term increases projects ROI



Excellent Low-Light Performance
Tier 1 certified solar cells allows better performance in low-light environments



Ideal for Large Scale Installations
Lower installations time and BOS (Balance of Systems) costs



Salt Mist and Ammonia Resistant
Certified by Bureau Veritas to withstand usage near coastal environments



PID resistant
Designed to minimise cell degradation in extreme environments



Secure Investment

Upsolar provides exceptional product coverage for all modules to ensure our customers achieve superior long-term value from their solar installations. To further improve our product warranty, which covers unanticipated module damage, we've recently expanded our terms from a 10-year period to a 12-year period.

In addition, Upsolar offers a 25-year performance guarantee known as the Linear Module Warranty. Whereas traditional policies feature a single trigger point leading to drastic coverage reductions after just 10 years, Upsolar's coverage more accurately corresponds to system performance, providing coverage for over 25-years.

Overall, our goal is to deliver not only top-notch modules, but also peace of mind, for decades to come.

*Upsolar has expanded its manufacturing operations in Asia, Europe and North America, keeping its modules duty-free in the event of new CVD or AD policies. Please ask about pricing, payment terms and conditions to meet your needs.

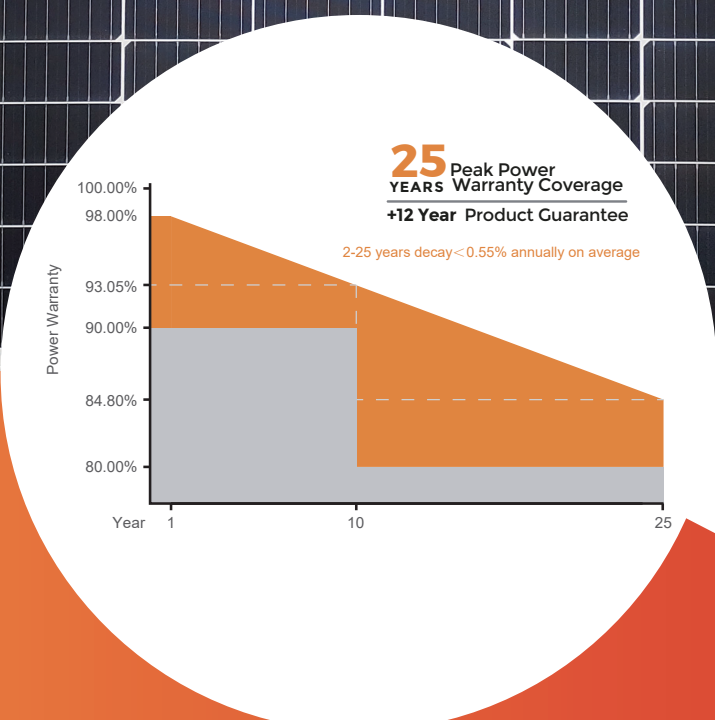

Bifacial Series | Mono 166 144 cells

Electrical Characteristics at STC

STC: Irradiance 1,000 W/m², Module temperature 25°C, AM=1.5

MODEL	UP-B450MH-T (72M6)	UP-B455MH-T (72M6)	UP-B460MH-T (72M6)	UP-B465MH-T (72M6)	UP-B470MH-T (72M6)
Max Power Pm at STC (Wp)	450	455	460	465	470
Max Power Voltage Vm (V)	41.35	41.55	41.75	41.95	42.15
Max Power Current Im (A)	10.88	10.95	11.02	11.08	11.15
Open-Circuit Voltage Voc (V)	49.55	49.75	49.95	50.15	50.35
Short-Circuit Current Isc (A)	11.60	11.68	11.76	11.84	11.92
Module Efficiency (STC)	20.70%	20.93%	21.16%	21.16%	21.62%
Bifacial Factor	0.70+/-0.05				

Bifacial Output-rearside Power Gain

5%	Max Power Pm (STC)	473	478	483	488	494
	Module Efficiency (STC)	21.74%	21.98%	22.22%	22.46%	22.70%
15%	Max Power Pm (STC)	518	523	529	535	541
	Module Efficiency (STC)	23.81%	24.07%	24.34%	24.60%	24.87%
25%	Max Power Pm (STC)	563	569	575	581	588
	Module Efficiency (STC)	25.88%	26.17%	26.45%	26.74%	27.03%

Components & Additional Data

Power tolerance	0/+3%
Front Glass	High Transparency Tempered Glass 0.126" // 3.2 mm
Junction Box	IP 68 or above
Output Cables	0.3m // IEC/ UL approved (4 mm ² , 12AWG) (PV Wire Type)
Connectors	MC4 compatible (IP67, IEC and UL approved)
Frame	Anodized aluminium alloy type 6063-T5
Encapsulation Material	EVA
Back Sheet	Transparent backsheet
Temperature Range	-40°F to +194°F // -40°C to +90°C
Series fuse rating	20A
Maximum system voltage	1,000V or 1,500V (IEC/UL)

Specifications

Cells	Monocrystalline bifacial solar cells 166 x 83
Number of Cells	144 (6 x 24)
Dimensions (in // mm)	82.44 x 40.86 x 1.38 // 2094 x 1038 x 35
Weight (lb // kg)	51.7 // 23.5

Temperature Coefficients

NMOT (°C)	43 ± 2
Temperature Coefficients of Isc (% / °C)	0.05 ± 0.01
Temperature Coefficients of Voc (% / °C)	-0.28 ± 0.02
Temperature Coefficients of Im (% / °C)	-0.02 ± 0.02
Temperature Coefficients of Vm (% / °C)	-0.30 ± 0.02
Temperature Coefficients of Pm (% / °C)	-0.35 ± 0.02

IV Curves

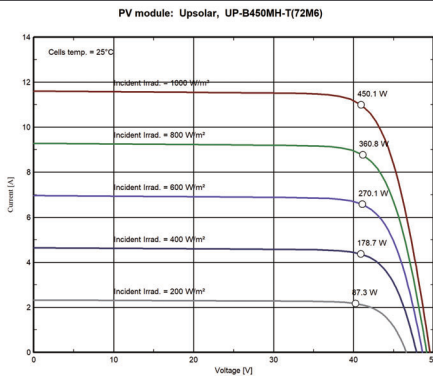

Options Available

Frameless option available
Glass-glass option available

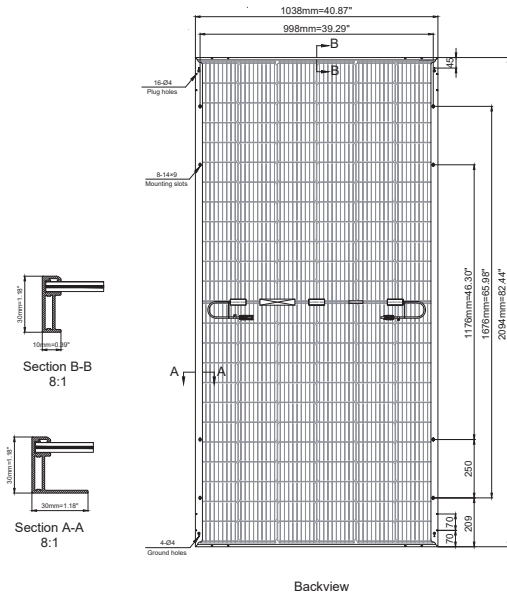

Backview