

VAZ® 1100 XL K FF

Vecoplan®

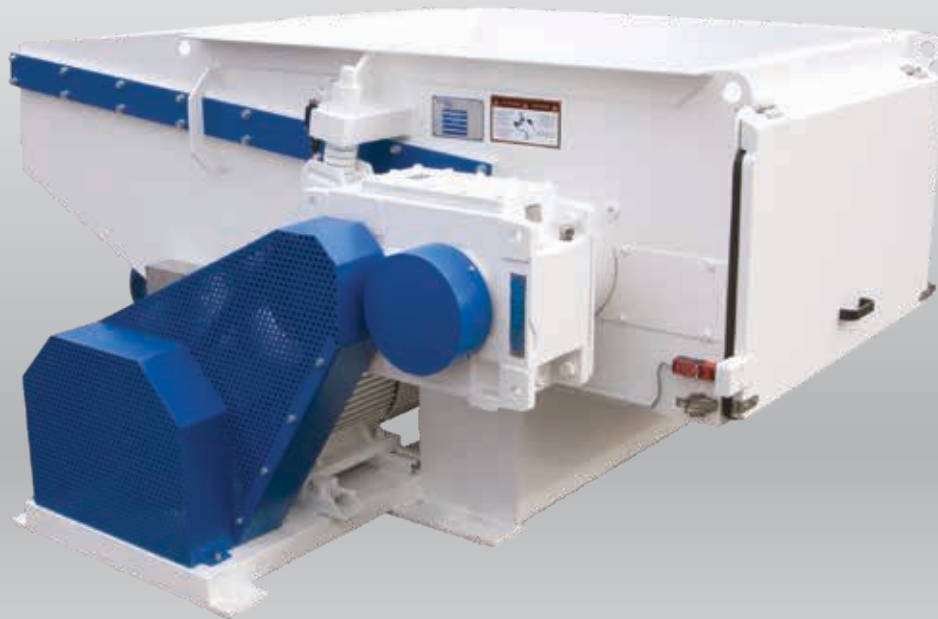

VAZ® 1100 XL K FF Film Fiber Shredder

The VAZ® 1100 XL K FF Rotary Shredder with the SureCut™ Cutting System is designed specifically for single-stage reduction of plastic films, synthetic fibers, and carpet being reclaimed for extrusion. The FF Series is built for high throughput, has built-in metering capabilities and thermal monitoring controls. Benefits of the SureCut™ Cutting System include precise cut lengths and high bulk densities.

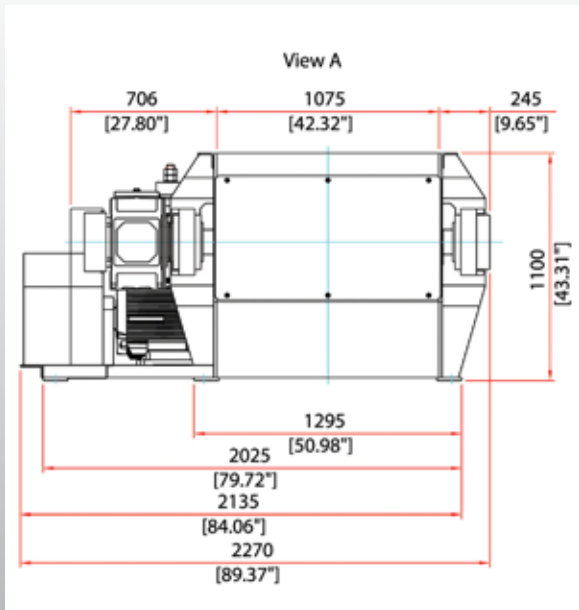

front view

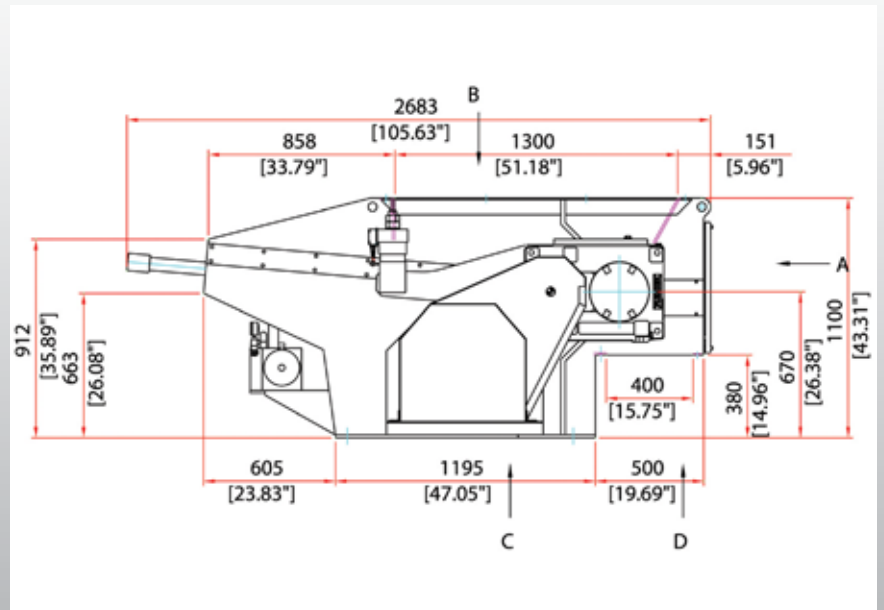

side view

Specifications

Hopper Opening	inch	42x52
Hopper Volume	cubic yards	2.9
Rotor Diameter	inch	15
No. of Cutters	qty	48 (40x40) + 23 (nip)
Rotor Speed	rpm	120
Drive Motor HP	HP	60
Feed System	HP/speed	3-5 / 2
Machine Weight	lbs	8,500
Voltage	V/PH/Hz	460/3/60

Options

- Variable Frequency Drives
- Optional Control Brands
- Quick Disconnect & Quick Clean Screens
- Application Specific Programming and Control Integration
- Multiple Rotor Configurations
- Multiple Cutter Insert Sizes
- Special Purpose Screens
- Hydraulic BridgeBreaker Vertical Feed Ram
- Airspring Counterknife for High Tramp Metal Content
- Complete Turn-Key Recycling and Reclamation Systems and Material Handling Products Installation

Features

- SureCut[™] Cutting System
- Low Speed / High Torque Design
- PLC Controls / Touch Pad Monitoring
- Tramp Metal Protection
- Large Infeed Hopper
- Precision Hydraulic "Process Ram"
- Composite 4-Way Indexable Cutting Inserts
- Rugged Hydraulics
- Lifetime Limited Warranty on Cutting Rotor
- Oversized Spherical Roller Bearings
- Fluid TurboCoupling
- ISO 9001 Manufactured
- Hinged Protective Cylinder Covers
- 0.015 Knife Gap for Thin Materials
- Easy Access Screen
- Critical Duty Drivetrain
- Passive Programming for Self-Feed Materials
- Wear Resistant Siderails & Cutting Chamber
- Reinforced Screens
- Heavy Viscosity Fluids
- Diverter Plate Over Cutting Rotor
- Built-In Thermal Monitoring Controls for Rotor