

UNTHA

shredding technology

The reliable brand!

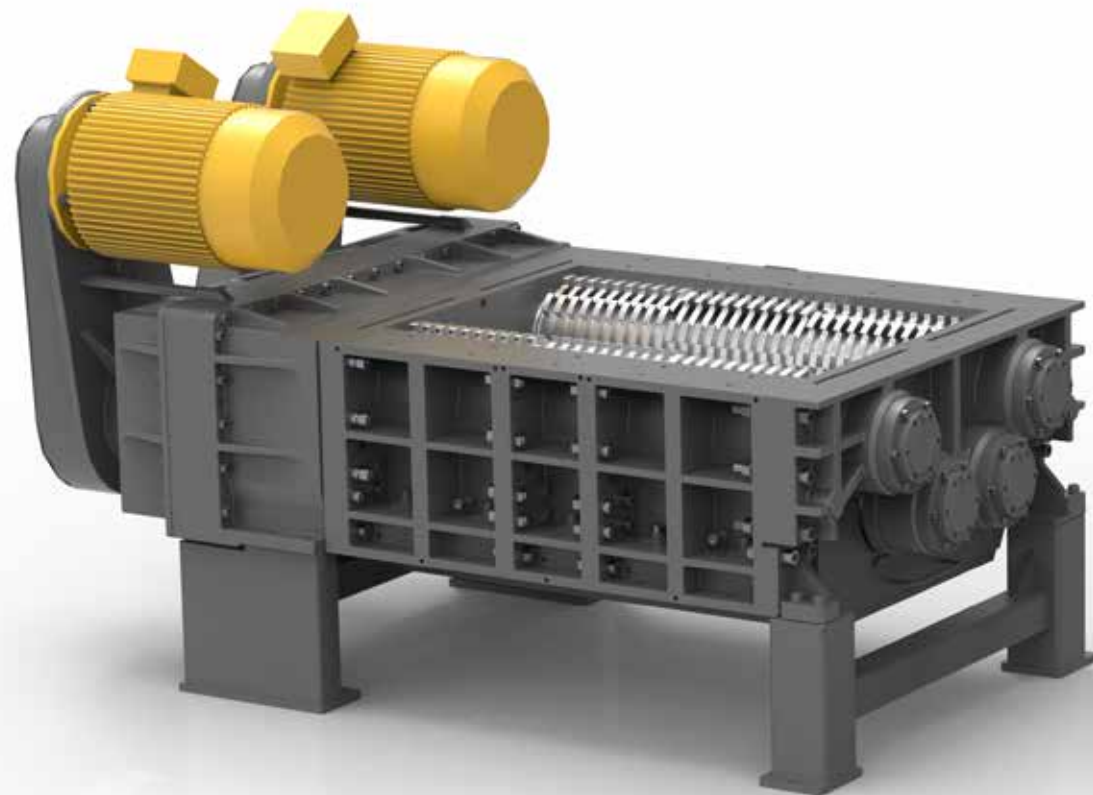

RS

4-SHAFT SHREDDING SYSTEM

RS50, RS60, RS100

THE HIGHEST RELIABILITY FOR THE TOUGHEST APPLICATIONS

The refined RS shredder models have stood the test of time and the toughest applications. With their great reliability and their ability to handle unshreddable items without problems, they excel in wide range of applications.

Speed, torque, cutting chamber, cutting systems, perforated screens and sealing variants – all these features can be individually configured to create customised machines that perfectly meet your demands.

Their rugged design and powerful, hard-wearing cutting systems make them the perfect equipment for multi-shift continuous operation.

FUNCTION AND DESIGN

After the material to be shredded has been drawn into the main cutters ①, it is both pre-shredded and re-shredded in a single pass. Material that does not fall through the screen ② is transferred to the secondary cutters ③ and moved back up and fed back into the cutting chamber for re-shredding. The screen determines the size of the final fraction.

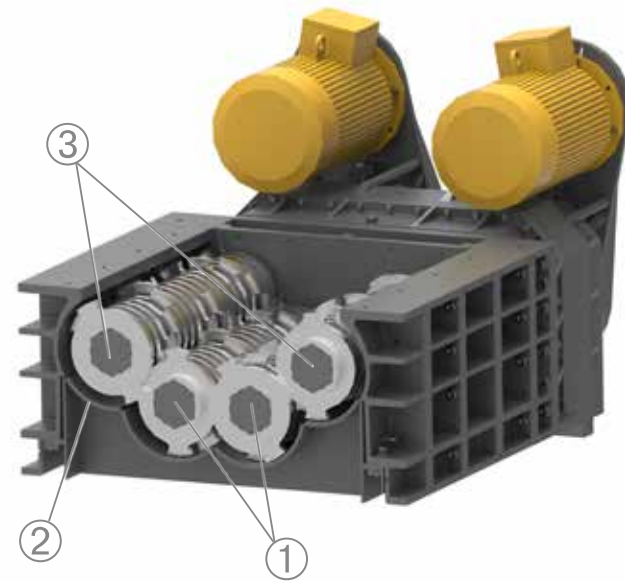

TYPICAL APPLICATIONS

- Aluminium profiles
- Dashboards
- Interior auto trim
- Bank notes
- Batteries
- Organic waste
- Cans
- Electronic scrap
- Electric cookers
- Cement asbestos boards
- Spring mattresses
- Plastic film
- Dishwashers
- Gypsum boards
- Green waste
- Rubber waste
- Domestic waste
- Cardboard packaging
- Cardboard tubes
- Plastic packaging
- Plastic drums
- Refrigerators
- Metals
- Medical waste
- Metal chips
- Metal drums
- Rubbish bins
- Oil filters
- Paper
- Paper rejects
- Plastic bottles
- Production waste
- Passenger car tyres
- Radioactive waste
- Shredder light fraction
- Hazardous waste
- Punching scrap
- Bumpers
- Carpets and rugs
- Tetra pack
- Textiles
- Workshop waste
- Packaging material
- etc.



UNTHA RESEARCH & DEVELOPMENT CENTRE

In 2000, UNTHA opened a modern research and development centre where trials and tests with customers' specific materials are simulated under practical conditions.

The focus is always on the customer and on fulfilling each task in the best possible manner. The technology centre enables us to gain important experience and data so we can offer the ideal shredding solution for any given task.

Take this opportunity and make an appointment at our test and demonstration centre!

QUALITY FEATURES

High availability

- > integrated electronic shut-down for unshreddable items
- > resistant to foreign material due to low speed cutting shafts
- > multiple shaft bearings for extra rigidity ①
- > multi-stage sealing system ② protecting gears and bearings
- > integrated and easy-to-replace cutting chamber bulkhead walls ③
- > straight forward design (no hydraulics, couplings, etc.) ensures reliable operation
- > rugged, reinforced steel frame
- > cutting disks with integral collar (no separate spacers) distributes cutting force over wide area

Operational advantages

- > reliable tooth belt drive ④ with two independent motors and rugged, heavy-duty gears
- > belt drive provides optimum shaft speed
- > consistent final particle size
- > one step pre- and re-shredding
- > self feeding for most materials – no ram required
- > quick change screen system
- > low noise and dust generation

Low noise and dust pollution

- > by low-speed cutting shafts

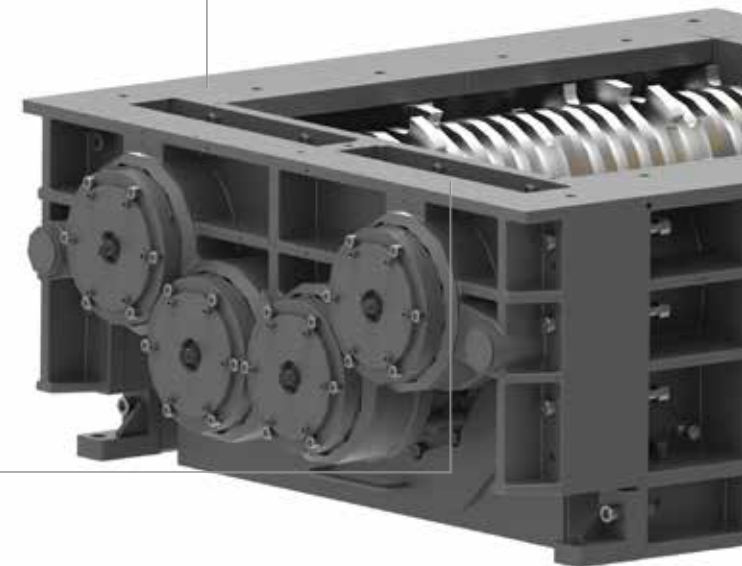
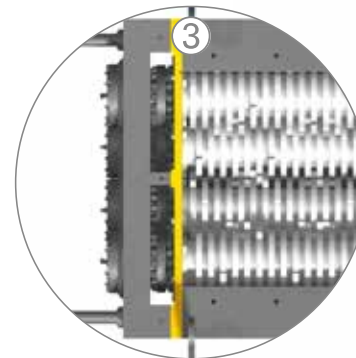
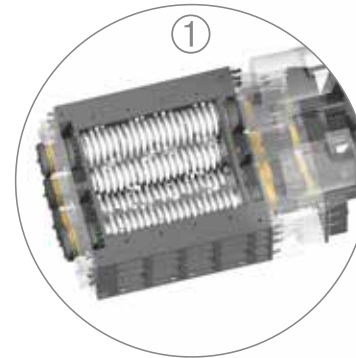

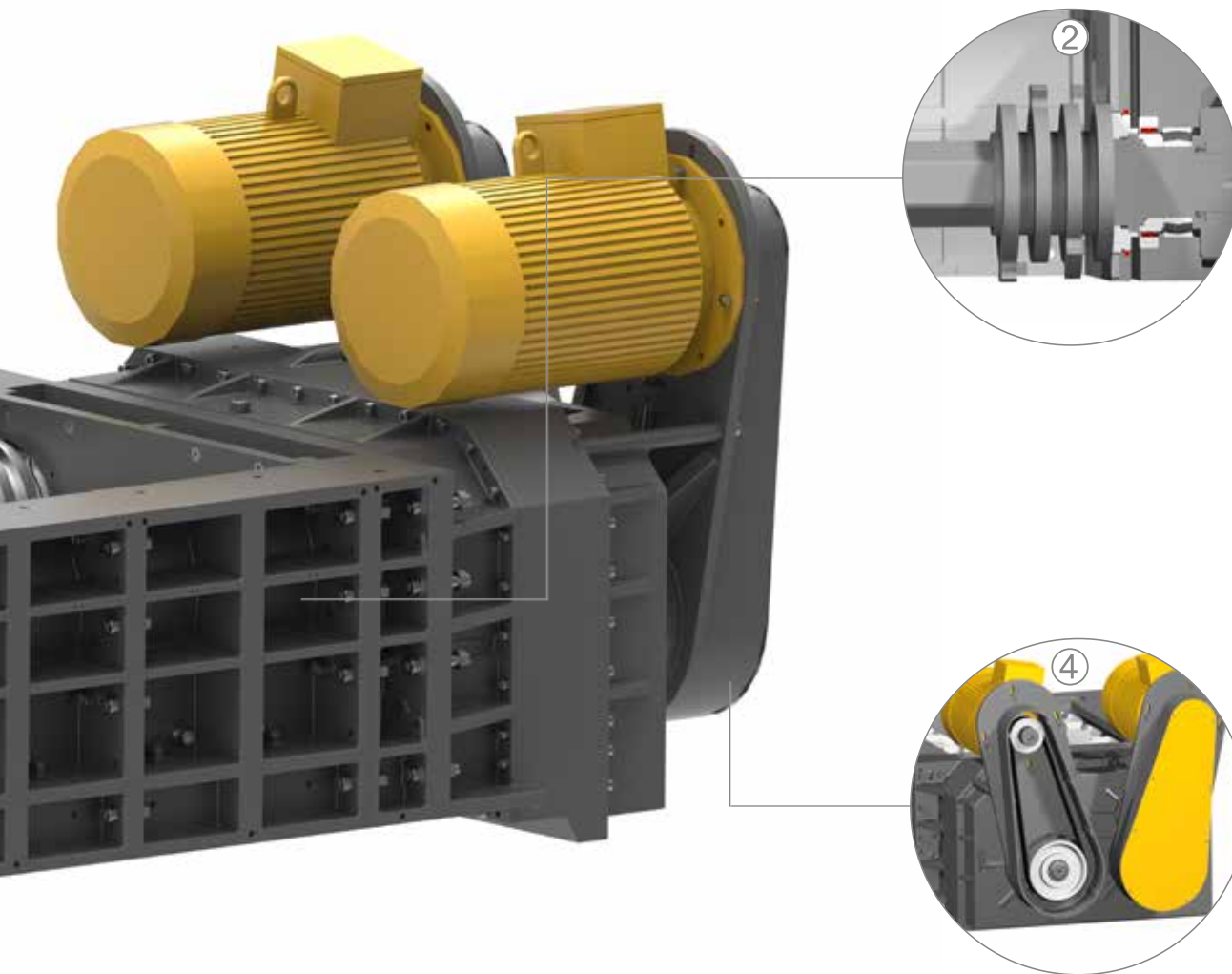

Functional design

- > can be loaded from all sides
- > more than 350 cutting system configurations available
- > modular system allows for tailor made solutions
- > compact design integrates into complex installations without difficulty
- > rugged cast iron frame

Unmatched in productivity

- > very large screen area ensures high throughput
- > high torque drive easily handles tough materials
- > low downtime with high availability

Options

- > hydraulic ram for bulky materials
- > variable frequency drive (VFD) speed control for adjustable throughput and reduction of start-up peaks
- > screw conveyor for efficient discharge of shredded material
- > automatic central lubrication system
- > active shaft ventilation for increased cutter life
- > dynamic cutting disc pre-loading system for easy change-out
- > wear plates
- > „UNTHA Carefree package“

A SELECTION OF IMPLEMENTED PROJECTS



Application: PCBs
Solution: RS50
Options: Stand, custom hopper
Location: Finland



Application: Hazardous waste
Solution: RS100
Options: Conveying system, ram device
Location: Italy



Application: Tyres from cars
Solution: RS50
Options: -
Location: Great Britain



Application: Printed circuit boards
Solution: RS60
Options: -
Location: USA



Application: Paper
Solution: RS100
Options: custom hopper
Location: Great Britain



Application: Hazardous waste
Solution: RS100
Options: Stand, Central lubrication system, ram device, conveying system
Location: Slovenia



Application: Hazardous waste
Solution: RS100
Options: Central lubrication system, custom hopper, stand, ram device, chute
Location: Great Britain



Application: Electronic scrap
Solution: RS100
Options: Screeners extended reach, custom hopper, ram device
Location: France

RS CLASS

TECHNICAL DATA		RS50	RS60	RS100
Power	kW	44/50/60	60/74	100/110/150
Cutting chamber (S)	mm	750/960/1.230 x 700	960/1.200/1.440 x 860	1.200/1.500 x 1.020
No. of cutting shafts		4	4	4
Speed main shafts	U/min	21 - 29	17 - 21	17 - 28
Speed secondary shafts	U/min	32 - 43	21 - 25	17 - 28
Perforated screen Ø	mm	15 - 40	15 - 100	30 - 100
Belt drive		yes	yes	yes
Weight	kg	2.600 - 3.200	4.000 - 5.300	9.000 - 12.000

All dimensions in mm.

RS50/RS60*/RS100**

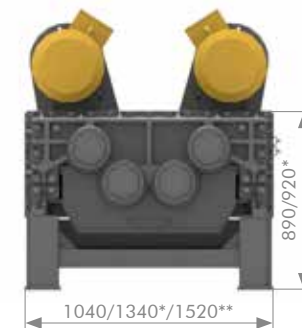
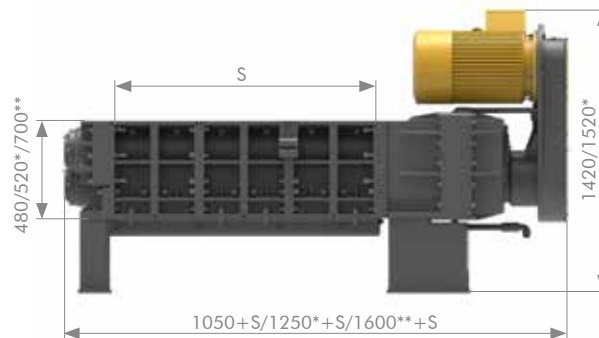

40 years of expertise.
More than 9,000 shredders in daily operation!



UNTHA

shredding technology

The reliable brand!



UNTHA shredding technology

Kellau 141
A-5431 Kuchl / Salzburg, Austria
Tel +43 6244 7016 0
Fax +43 6244 7016 1
info@untha.com
www.untha.com

Authorised partner of UNTHA

