

↓ TECHNOLOGY FOR YOU

Enjoy The Experience



ECOPRES AUTOMATIC

Steel Belt Conveyor Feeding

Auto-Tie Horizontal Channel Baler

CE

FLEXIBLE SOLUTIONS FOR

Low capacity Bailing needs

Low Cost Investment

HIGH EFFICIENCY

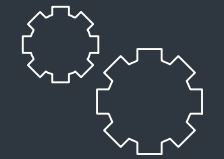

CUSTOMER SOLUTIONS

It's very important for us to response our customers demand for cost-effective solution.



BUSINESS SOLUTIONS

Create functionality without departing from the solutions, the primary target to increase the efficiency of the workplace.



SOME APPLICATIONS

- SOLID WASTE PLANTS
- PET PLASTIC RECYCLING
- FIBER TEXTILE WASTE
- PAPER CARDBOARD RECYCLING

- Nylon, paper and like this other waste materials bale weight up to 650Kg.
- Robust body structure for maximum compression.
- With Large and wide-mouthed loading chamber.
- Secure bale removal
- Loading height reduced "Appropriate for bulk materials"



TECHNICAL SPECIFICATIONS

- BALE SIZE : 110 X 75 X 100-150 CM
- MOTOR POWER : 15 KW
- FEEDING HOPPER : 145 X 105 CM
- RAM PRESSURE : 75 TONS
- CAPACITY : 4-5 TONS / HOUR
- AUTO BINDING : 4 LINE HORIZONTAL
- CONVEYOR : STEEL CHAIN ANGLE TYPE
- AUTOMATION SYSTEM : BY PLC
- HYDRAULIC SYSTEM : HYDROLOGICAL BLOCK
- HYDRAULIC PUMP : VARIABLE DISPLACEMENT PISTON PUMP

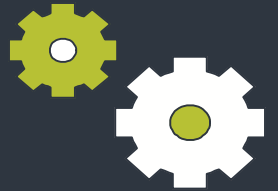

QUALITY

When we design machine we pay attention to safety, functionality, durability & aesthetics with the cost effective way.



SPARE PARTS

Hydraulic, electric and other parts we use are from the best brands in the world so parts are available everywhere.

40 Years of Expertise

More Than 2500 Machines in Daily Operations

TEKNİK ÇİZİM

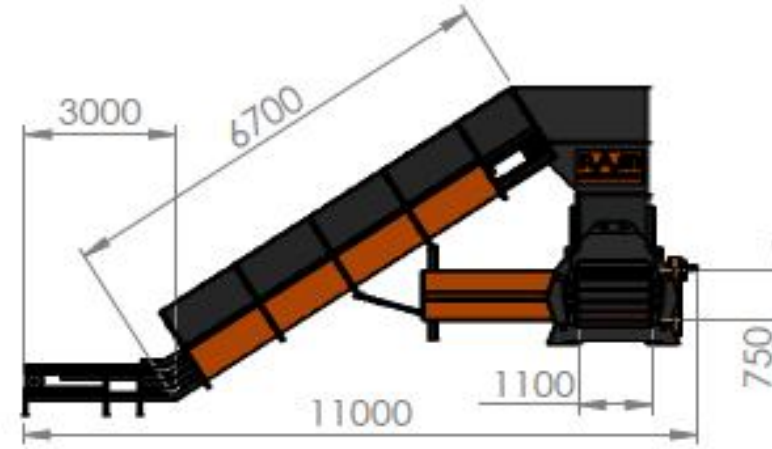
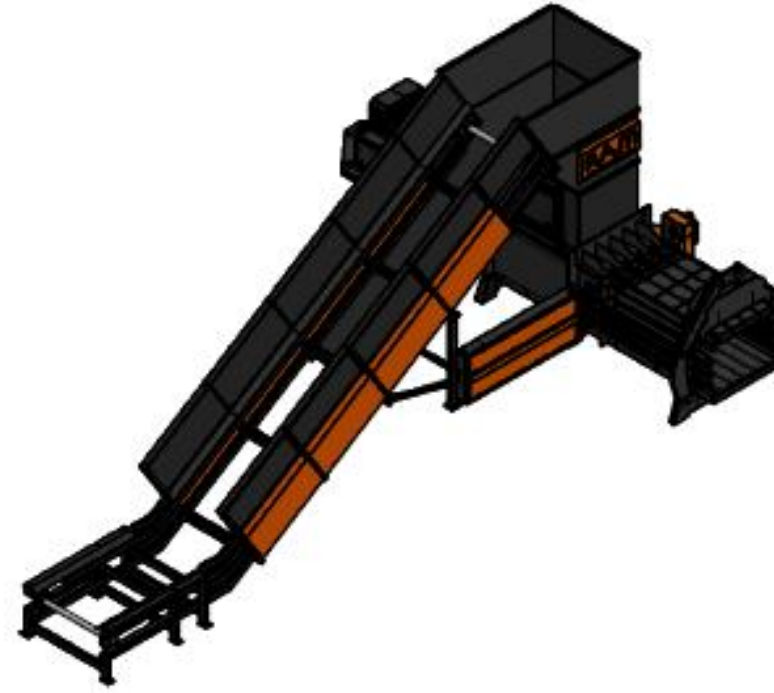
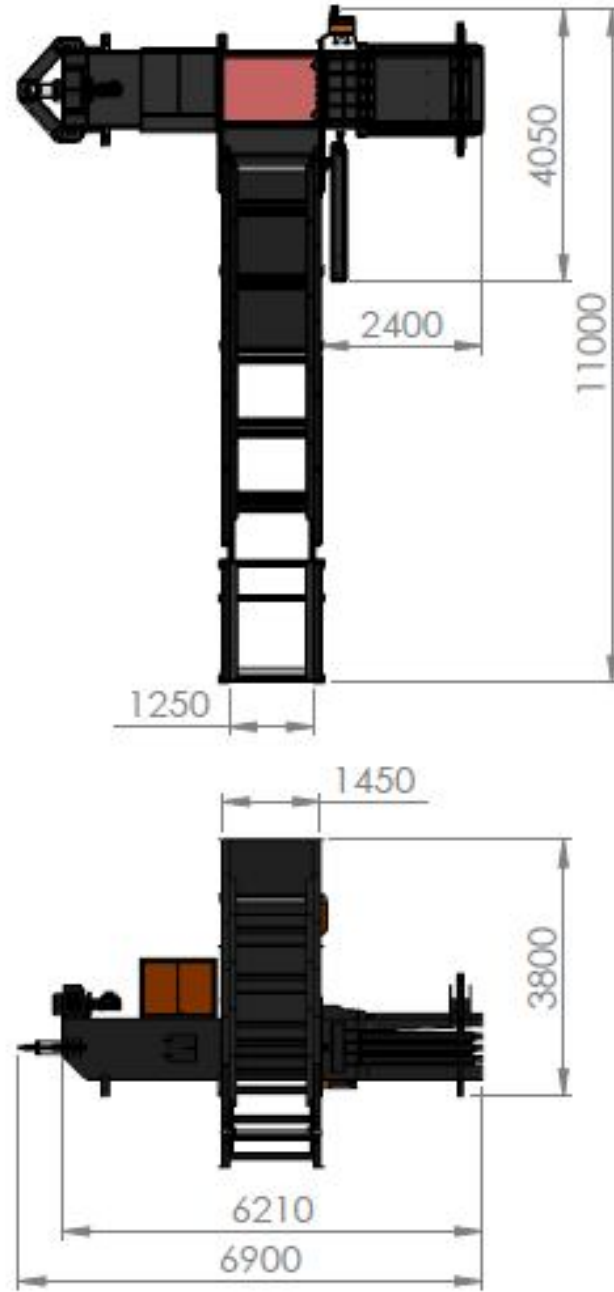

	PLAN MAKİNA San.Tic.Ltd.Şti. www.planmakina.com.tr	Name of project / İlin adı
Name / İsim	Date / Tarih	Material / Malzeme
		SPR-75ES



ACTUAL TECHNOLOGY
PROVIDES THE
PRODUCTIVITY

INDUSTRIAL
SOLUTIONS

LATEST
TECHNOLOGY

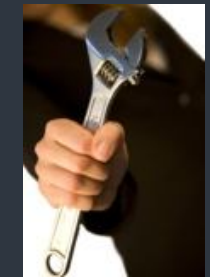

SERVICE

The most important
need for our
customers is fast
service.
We response for our
machine promptly
within 24 hours.

BUSINESS SOLUTIONS PARTNERS



PLAN MAKİNA SAN. VE TİC.LTD.ŞTİ.
SAZYOLU CAD.NO:8 YAZIBAŞI TORBALI İZMİR TÜRKİYE
T: +90(232)8539623 F: +90(232)8539626
info@planmakina.com.tr www.planmakina.com.tr