

NP40-II, the silent-running electro-mechanical baler, is fast, easy and safe to work with.

Open the feed door and load the waste, close the door and the waste is compacted automatically.

When the bale is ready to be ejected the indicator lamp is lit. The bale ejection strap makes it easy to eject the bale.

New technique and design that adds functions and simplifies operation:

Plug'n Press - the modern control system surveys starting-up and operation.

Stay'n hold - the press ram stops in compaction mode (with full press power), giving more compact bales. Suitable for materials that raise up. During 'Stay'n hold' no electricity is needed.

Autostart - the baler starts compacting automatically when the feed door is closed.

Both 'Autostart' and 'Stay'n Hold' can be switched on/off.

- ▶ Compacts most material: paper, cardboard, soft and hard plastic etc.
- ▶ Easily located on a minimum of floor space (ca 0.75 m²)
- ▶ Convenient operating height
- ▶ Total height below 1,80 m!
- ▶ Very reliable, proven long-lasting performance, even out-doors
- ▶ No hydraulic oil



Thanks to its low height, the NP40-II can be placed near the source and can easily be relocated with a pallet truck by changing needs.

Distinctness



The NP40-II has the same control system as the larger balers. It can easily provide additional features for customized solutions.

Efficiency



Efficient sorting near the source. The NP40-II is silent-running and provides a good work environment.

Capacity



High capacity thanks to low loading height and generous feed volume.

Volume reduction



A volume reduction of up to 95%! The built-in ejection device simplifies the ejection of bale.

NP40-II baler

- no waste of space -

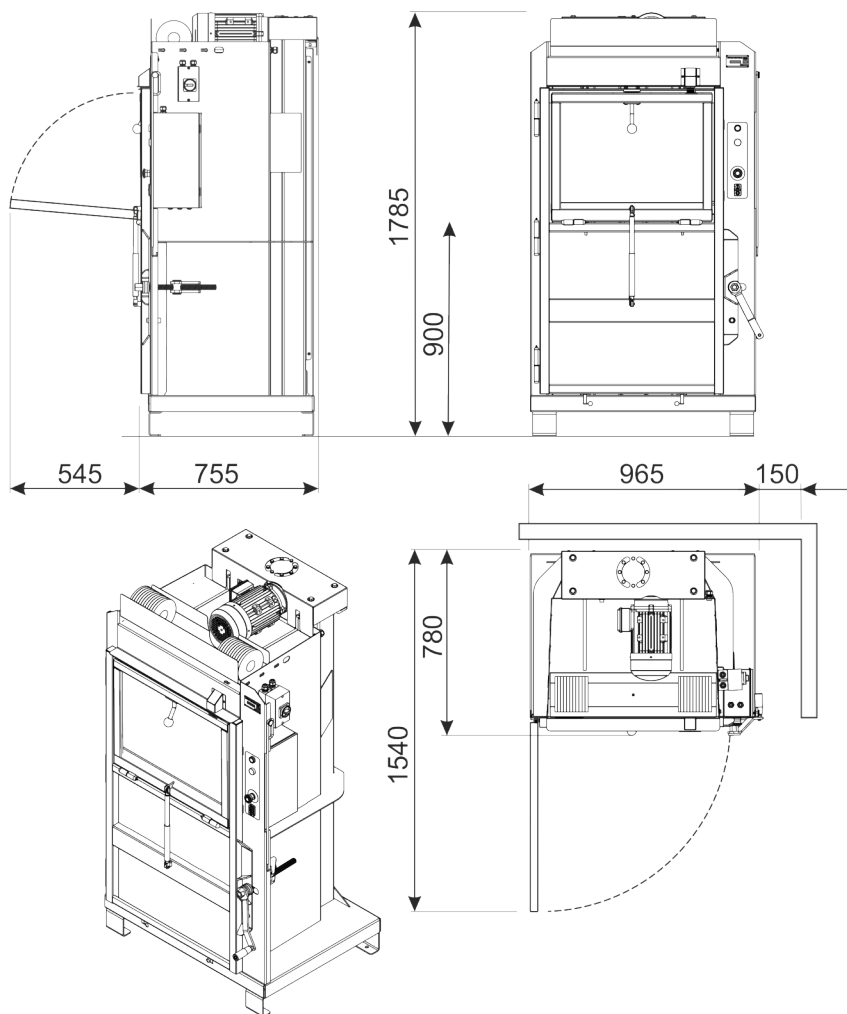

The feed door opens 90° as standard, but can be opened all the way down 180° for customized needs.

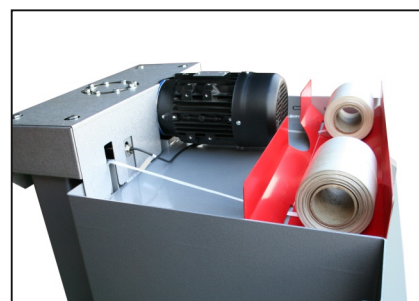

The bale strapping rolls are easily reached at the top. Each roll can be replaced separately.



Since the mid-sixties more than 15,000 NVA balers have been delivered all over the world.



Our continuous development in close co-operation with users world wide gives us a unique knowledge of compacting and recycling.

The result is an outstanding range of products representing good design with excellent performance.

All compactors from NVA carry the CE-mark.



Model	Pressure kN	Weight kg	Feed opening mm	Bale size mm			Bale weight kg	dB(A)
				Length	Width	Height		
NP40-II	60	370	700 x 500	500	700	700-800	40 - 80	57

Voltage: 3-phase 400 V, 50 Hz in standard version. Other voltages available.

NP40-II is one of the balers in our range - please contact us for more information of other products!

We reserve the right to introduce technical alterations.

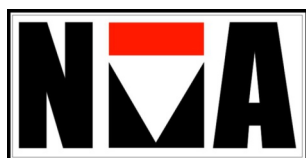

NÄTTRABY VERKTYGS AB
 Angelskogsvägen 8, SE - 372 38 RONNEBY
 Tel. +46 457 19220
 www.nva.se - info@nva.se
 SWEDEN

