

LP 85 VH2 Prepress Technology Baler



The baler

- Robust design with highest possible reliability.
- User and service friendly.
- Optimized bale size and big feed opening.
- Unique pressure control of friction channel by means of two heavy duty pulling cylinders.
- All exposed zones in high-tensile steel.
- Press chamber floor in 20 mm high-tensile steel.
- Exchangeable high-tensile steel plates in press chamber and friction channel (option).
- Friction channel in compact design for reduced wastage.
- Main press top and bottom with cam design for better sealing.
- Main press rolling on four heavy-duty wheels guided on wear rails.
- Main press with sturdy wear blocks on sides and top.
- Heavy duty bearings for the pre-press shaft.
- Detection system of the pre-press position during operation to secure a safe interlock of inspection hatches and protection covers.

The pre-press technology

- Ensures that the material always produces a constant counter pressure in the main press chamber.
- Up to 50 % lower energy consumption compared to a baler without prepress.
- No knives on the main ram, no risk for material jamming between knives and press plate.
- All of the press force utilized for material compaction.
- Increased volume capacity of the machine; the number of pre-pressing operations may be determined depending on the material to be baled.
- Guarantees an even density throughout the bale = square bales.
- Makes it possible to bale big size material without using a shredder.
- Makes it possible to bale most recyclables to dense, square bales.
- Low service and maintenance costs.

The hydraulics

- Main drive motors 2 * 45 kW with a double hydraulic pump system.
- Oil level control system
- Oil temperature transmitter - oil temperature indicated on control panel screen
- Oil cooler
- Oil heater (optional)

The strapping

- Strapping system with five vertical needles.
- Simple and reliable twisting unit with an eccentric drive, service friendly, easy access.
- The number of twistings and twisting force adjustable for an optimized relation between wire consumption and stability of the ready bale.
- Very short pigtails (wire ends) - no waste of wire.
- Wire guiding system for big wire coils.
- An additional strapping unit with three horizontal wires for maximum bale weight when baling PET bottles and other expandable materials (option).

The control system

- PREMI 2.0 HMI Interface system with a fixed Internet connection for operation control and monitoring, presetting of 20 baling programmes.
- Easy operation with a 12" colour Touch Screen
- Quick couplings for quick and safe installation
- A photocell system for baler and conveyor control

LP 85 VH2 Dimensions

Presona[®]

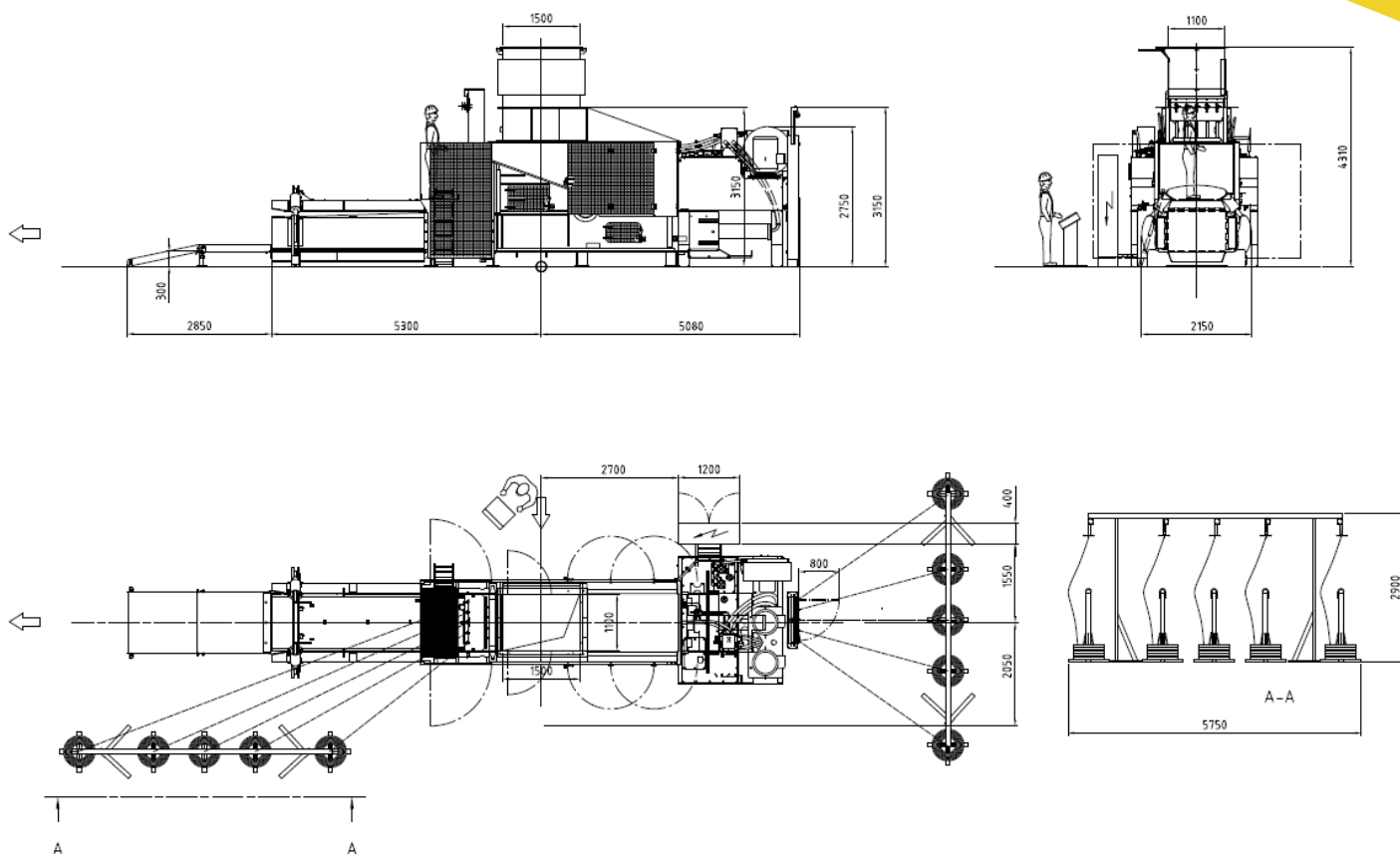

Subject to alterations / Änderungen vorbehalten

Technical Data		LP 85 VHI	LP 85 VH2
Theoretical volume capacity	m ³ /h	930	1200
Max volume capacity	m ³ /h	410	560
Weight capacity*	t/h	9 - 25	13 - 30
Feed opening L x W	mm	1500 x 1100	1500 x 1100
Bale size H x W (Length variable)	mm	750 x 1100	750 x 1100
Bale weight	kg/m ³	450 - 650	450 - 650
No. of vertical strapping wires		5	5
Press force pre-press	t	28	28
Press force main press	t	85	85
Specific pressure	N/cm ²	100	100
Max oil pressure	Bar	270	270
Oil tank capacity	Litres	1000	2000
Electric motor	kW	55	2 x 45
Oil cooler	kW	1 x 3,0 + 0,37	1 x 3,0 + 1,5
Machine weight	t	~ 25	~ 27

* At a material pre-bale density of 30 - 100 Kg/m³

Performance rates and bale densities are subject to moisture, material pre-bale densities, feed rate and other variables when baling.

As part of our continuous product development, specifications are subject to change without notice.