

WastePac 200 Multi Baler



BALER DIMENSIONS

Height	2.469 m
Width	3.032 m
Depth	1.269 m
Weight	1400 kg
Transportation Height	2.469 m
Power Supply	240V 1 Phase
Motor	2.2kW 16A
Pressing Force	Up to 16T
Noise Level	74 dB
Cycle Time	34 Seconds

BALE DIMENSIONS

Height	1.000 m
Width	1.074 m
Depth	0.800 m
Weight	Up to 200kg

LOADING APERTURE SIZES

Depth	0.800 m
Width	1.074 m



200 Multi BALER FEATURES

- Save handling time with multiple chambers
- Multiple chambers offer an efficient way of separating different materials
- Roller guided head for ease of movement
- Retainer claws to prevent spring back of material
- Top loading baler
- Suitable for height restricted areas
- Fully automated bale ejector

OPTIONAL EXTRAS

- Up to six additional chambers may be added
- Available in either 110/380/400 volts power supply
- PLC panel with automatic compaction cycles and bale full light



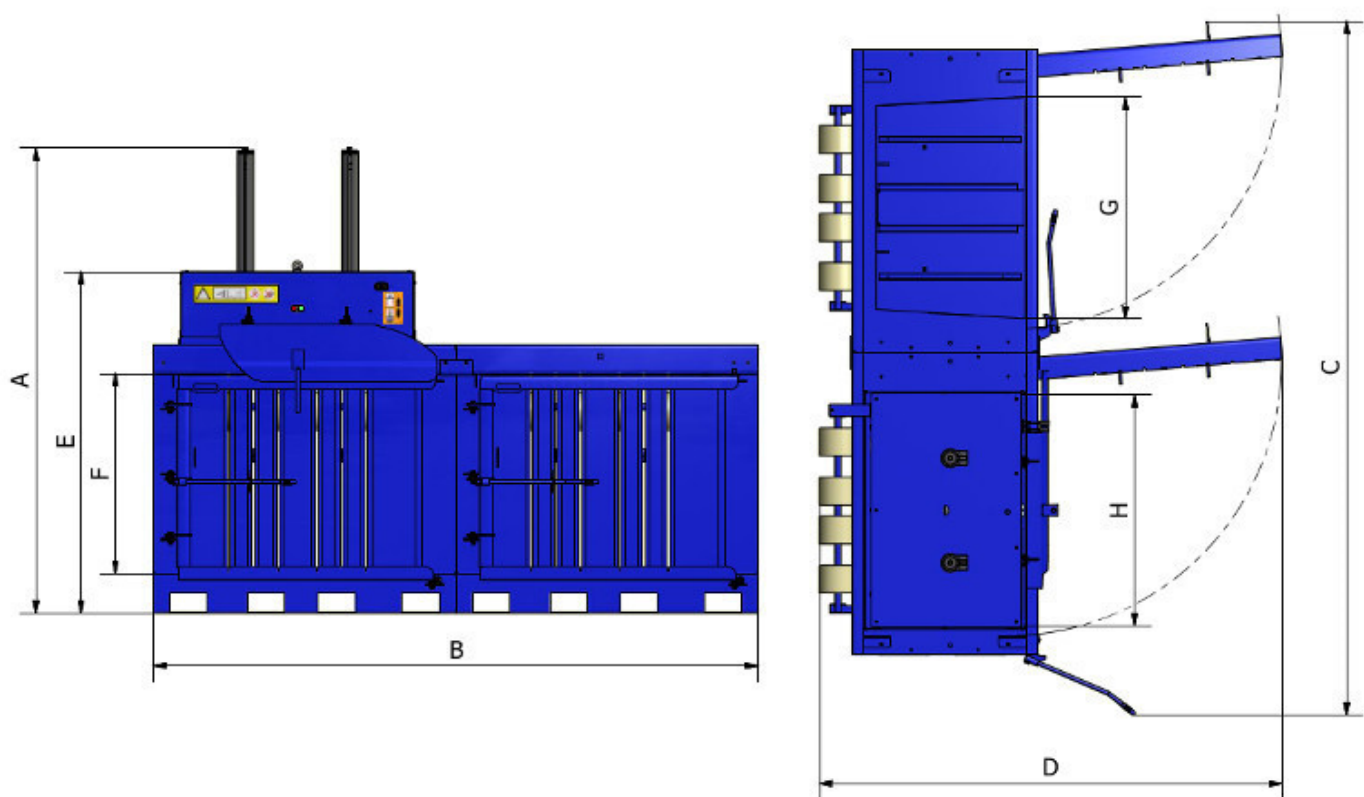

A 2.469 m

B 3.032 m

C 3.740 m

D 2.493 m

E 2.469 m

F 1.078 m

G 1.194 m

H 1.244 m

I 1.630 m