

Horizontal Baler

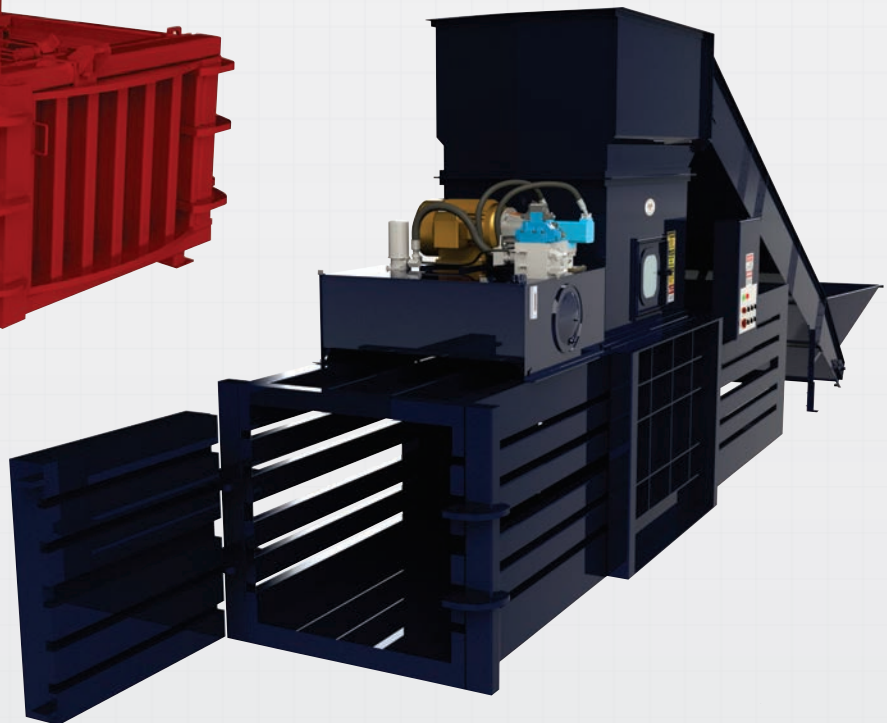

CRAM-A-LOT®
J.V. Manufacturing, Inc.
Solid Waste & Recycling Equipment

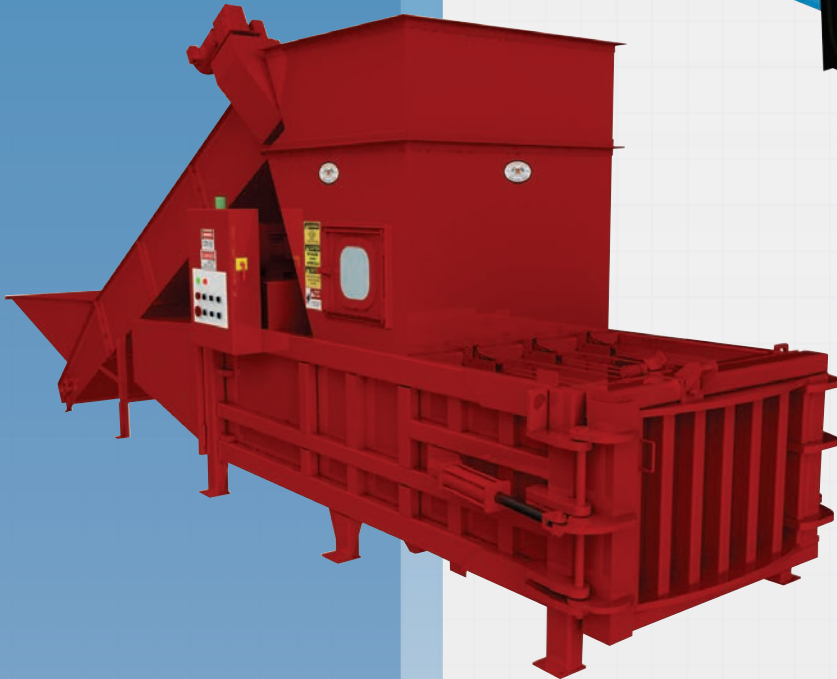
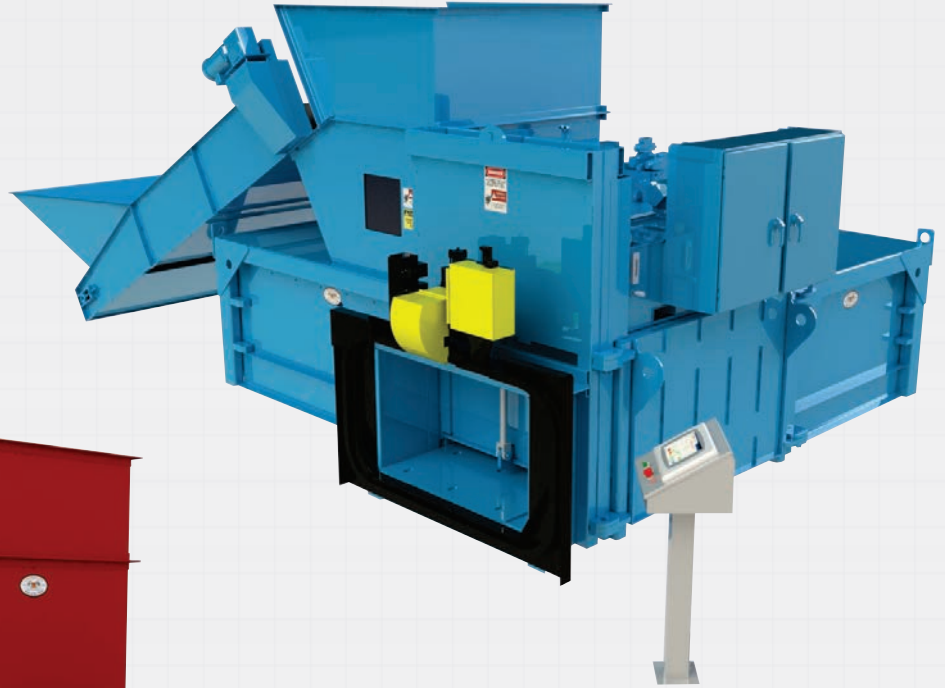

“Equipping The World For A Better Environment”

Features

Our range of Horizontal Balers are high performance machines designed to process a variety of recyclable materials into high density bales.

THESE POWERFUL UNITS ARE IDEAL FOR:

- Recycling Centers
- Distribution Centers
- Factories & Industry
- High Volume Material Generators
- Material Recovery Facilities

DESIGNED FOR:

- Baling a Variety of Materials
- High Volume Processing
- High Density Bales
- Safe & Efficient Operation

HX SERIES CLOSED END

The HX series closed end balers are superbly suited to Distribution Centers and Industrial applications where large volumes of single material types are being processed, including cardboard, shrink wrap, newsprint, and cloth.

HE-60 "BIG MOUTH"

This full penetration, wide mouth baler is ideal for recycling centers that are processing a variety of material types, including OCC, PET, aluminum cans, and shrinkwrap. This baler produces a 60" x 30" x 48" mill-ready bale, and can produce undersized bales if required.

H2R-60 AUTO TIE

NEW!!

The H2R-60 is the flagship of the Cram-A-Lot range of horizontal balers. This two ram, auto tie baler is designed for Material Recovery Facilities, Recycling Centers, and Distribution Centers that need to process high volumes of recyclables daily. The auto tie feature reduces labor costs and increases throughput.

MATERIAL HANDLING SOLUTIONS

We offer a variety of custom engineered material handling solutions to feed your horizontal baler easily and efficiently, including standard conveyors, pit conveyors, tippers, and custom designed carts.

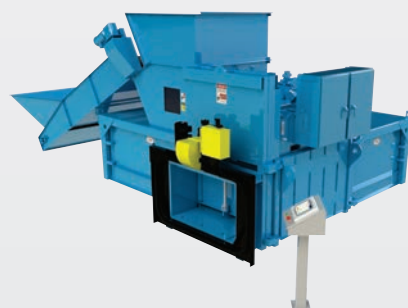
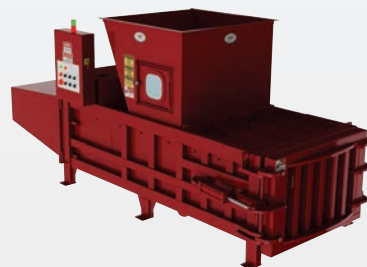
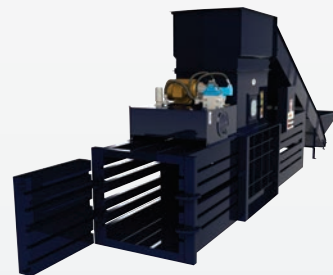

Installed Applications



CRAM-A-LOT[®]
J.V. Manufacturing, Inc. 
Solid Waste & Recycling Equipment

HE-60 with Walk-on Dock Mount



H2R-60 with Conveyor



HX-72 with Over the Back Conveyor

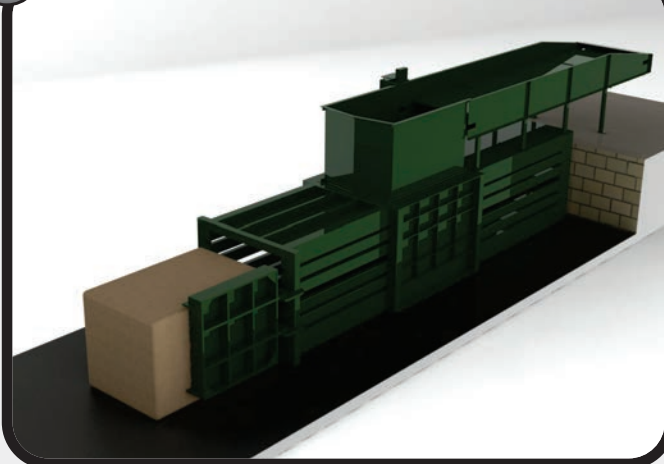

Walk-on Platform & Remote Power Unit



HE-60 with Sorting Conveyor

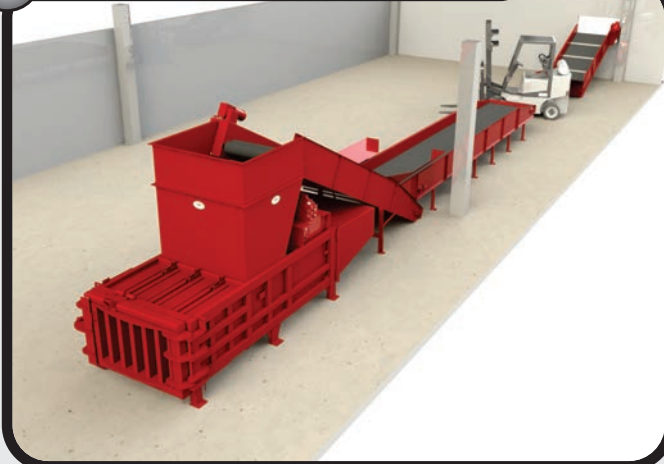

HX-72 with Left Hand Open Hopper

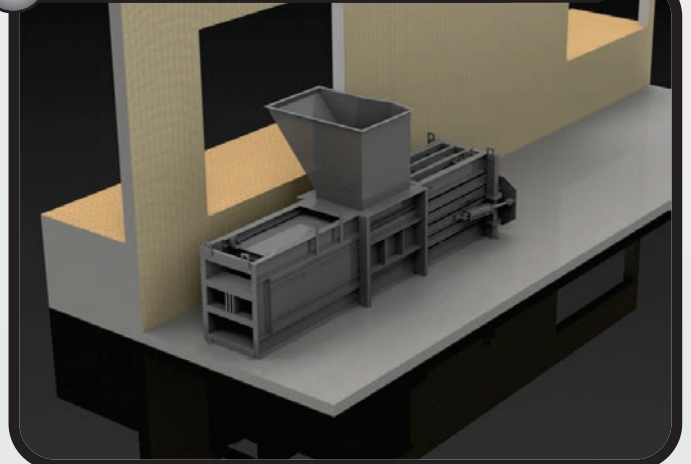

HX Series Closed End Balers

Our HX Series balers have withstood the test of time and represent an excellent value, reliability, durability, and high performance at a fair price!

FEATURES

- UL/CUL listed Control Panel
- WASTECC Rated
- Programmable Controller
- Adjustable Hardened Shear Blade
- Automatic Bale Sizing System
- Full-bale and Advance Warning Indicators
- Automatic Bale Ejection System
- Auto-cycle with Photocell
- Start-up Alarm & Light
- Name Brand Electrical & Hydraulic Components
- Custom Hoppers Available

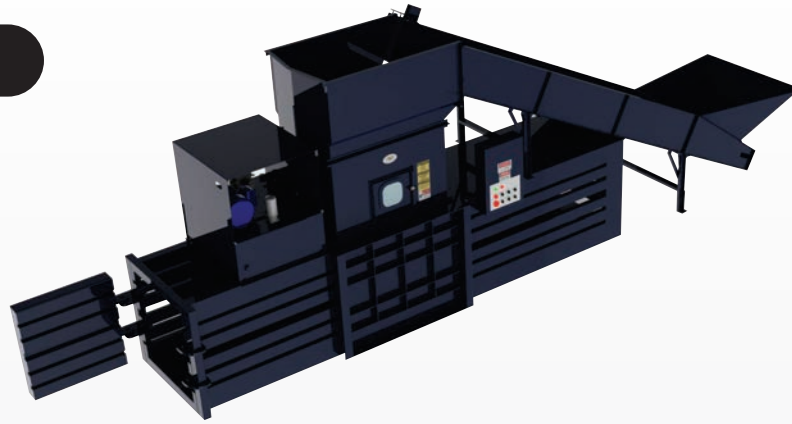

Cram-A-Lot HX Series Balers are designed for ease of installation, operation, & maintenance. These balers can process a wide variety of materials including OCC, newsprint, office paper, aluminum cans, PET bottles, shrink wrap, and cloth.

DESIGN FEATURES

- Heavy Duty construction provides long service life
- Automatic Cycle feature controlled by Photocell
- Power Source IHM (Integrated Hydraulic Manifold) system reduces the number of hydraulic hoses & fittings, providing a cleaner, more reliable and more durable hydraulic system.
- Hydraulic Door Latch
- Conveyor Feed Controls with Photocell
- Conforms to all current ANSI Z 245.5 safety standards
- WASTECC Rated

OPTIONAL FEATURES

- Remote Power Unit
- Oil Cooler
- Oil Heater
- Biodegradable Oil
- Custom Hopper Solutions
- Standard or Pit Conveyor Systems





CRAM-A-LOT®
 J.V. Manufacturing, Inc. 
 Solid Waste & Recycling Equipment

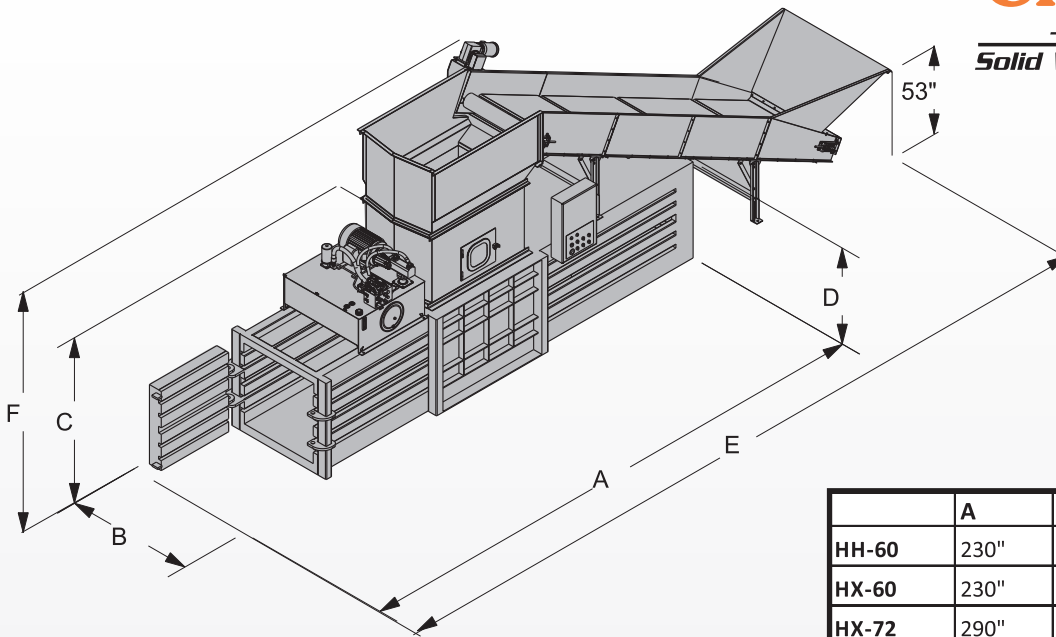

	A	B	C	D	E	F
HH-60	230"	46"	91"	49"	378-1/2"	121"
HX-60	230"	46"	91"	49"	378-1/2"	121"
HX-72	290"	60"	100"	58"	449-1/2"	143"
HX-72-W	314"	66"	100"	58"	461-1/2"	145-1/2"

Specifications

Model		HH-60	HX-60	HX-72	HX-72-W
Nominal Bale Size	L	60"	60"	72"	72"
	W	30"	30"	42"	48"
	H	40"	40"	48"	48"
Bale Weight Up to	(OCC)	1,100 lbs	1,400 lbs	2,200 lbs	2,400 lbs
Throughput	(OCC)	2.5 bales per hr	2.5 bales per hr	2.5 bales per hr	2.5 bales per hr
Main Cylinder	B	7"	7"	8"	8"
	S	54"	54"	70"	82"
	R	4"	4"	5"	5"
Door Cylinder	B	4"	4"	4"	4"
	S	12"	12"	12"	12"
	R	1-3/4"	1-3/4"	1-3/4"	1-3/4"
Motor		20 hp	25 hp	30 hp	30 hp
Pump @ 1800 rpm		37.5 Gpm	37.5 Gpm	63 Gpm	63 Gpm
System Pressure	Normal	2,000 psi	2,800 psi	2,000 psi	2,000 psi
	Maximum	2,400 psi	3,100 psi	2,400 psi	2,400 psi
Platen Force	Normal	76,900 lbs	107,700 lbs	100,500 lbs	100,500 lbs
	Maximum	92,300 lbs	119,300 lbs	120,600 lbs	120,600 lbs
Platen Face Pressure	Normal	65.2 psi	91.3 psi	50.5 psi	44.1 psi
	Maximum	78.2 psi	101.1 psi	60.5 psi	52.9 psi
Cycle Time no load		24 sec	24 sec	23.5 sec	27.5 sec
Unit Weight		13,000 lbs	13,500 lbs	15,900 lbs	16,500 lbs
WASTEC Rated Size		1.11 yd ³	1.11 yd ³	2.42 yd ³	3.36 yd ³

Special modifications quoted upon request

All information is subject to engineering and/or other changes without notice

Conveyors

We offer several conveyor systems to meet your unique material handling needs. Available in 30", 36", 48", & 60" width and lengths from 10ft to 32ft. Conveyors come equipped with 1 1/2 or 2hp motors, 30:1 gear reducer, and PVC-120 roughtop belts. Cleated or uncleated belts are available.

Sorting Conveyor

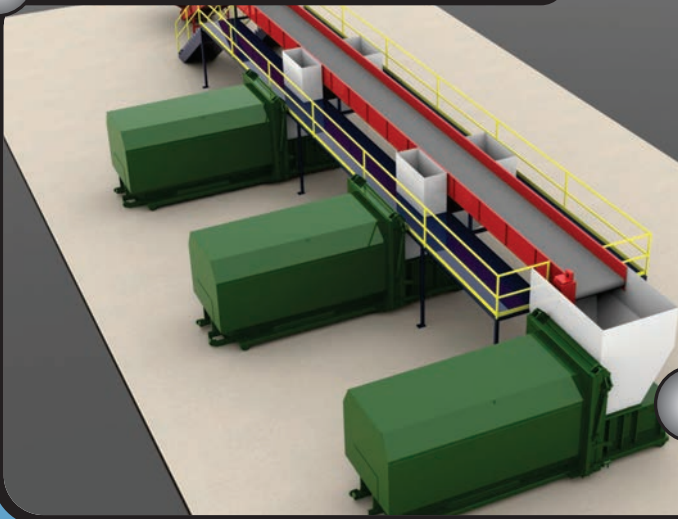

HX with Dual Conveyor

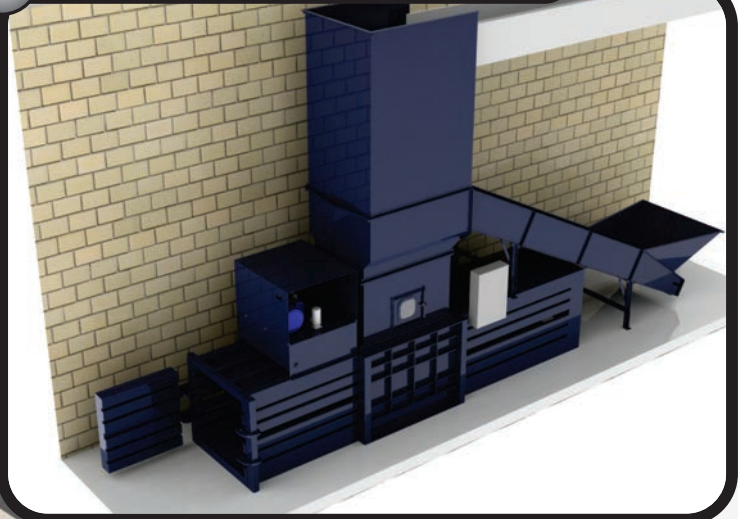

Sorting Conveyor

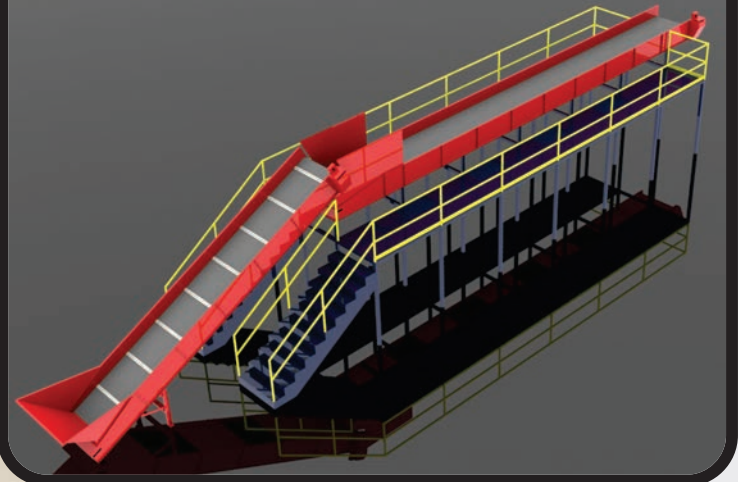

HE-60 with Pit Conveyor

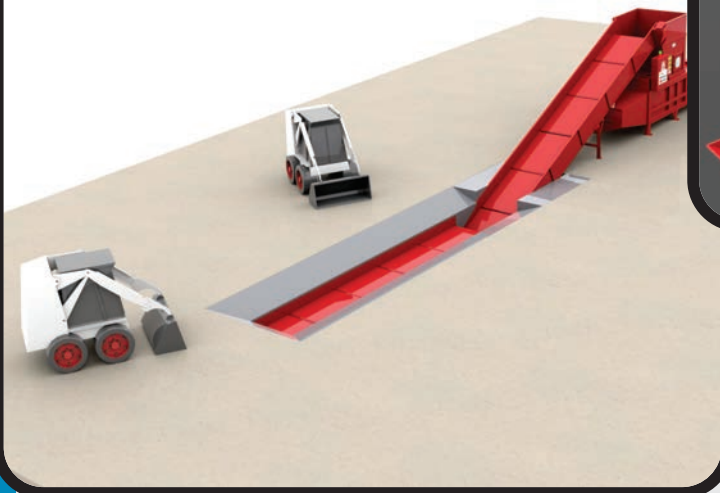

Specialty Applications



CRAM-A-LOT®
J.V. Manufacturing, Inc.
Solid Waste & Recycling Equipment

HX with Walk-on Platform

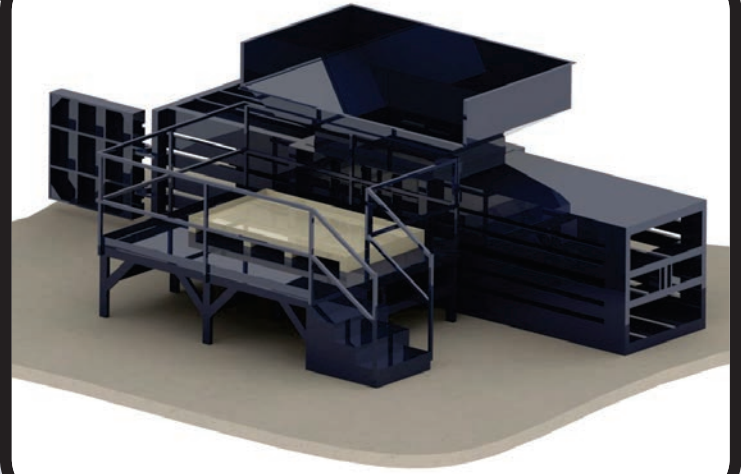

HE with Rear Conveyor & Tipper



HX with Rear Conveyor & Tipper

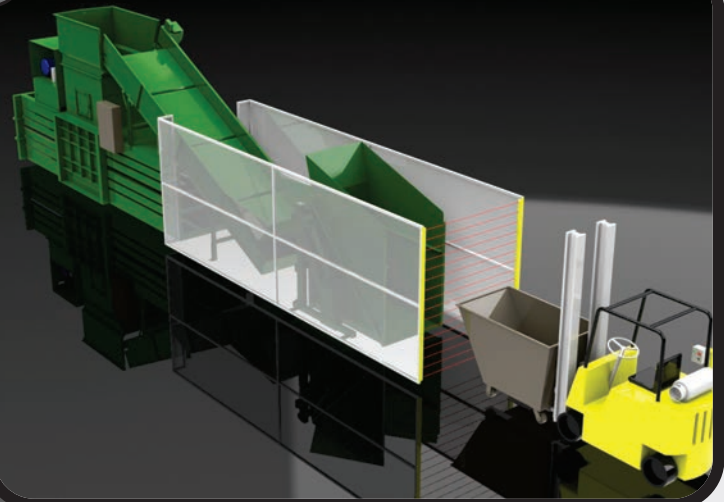

HX with Side Conveyor & Tipper

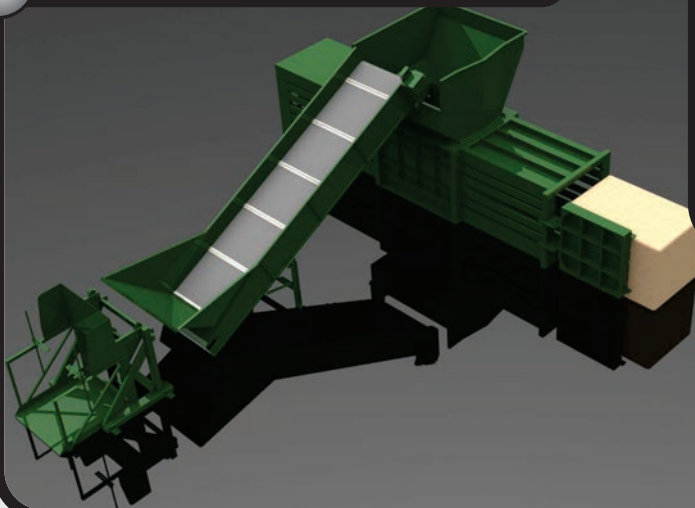



CRAM-A-LOT®

J.V. Manufacturing, Inc.

Solid Waste & Recycling Equipment

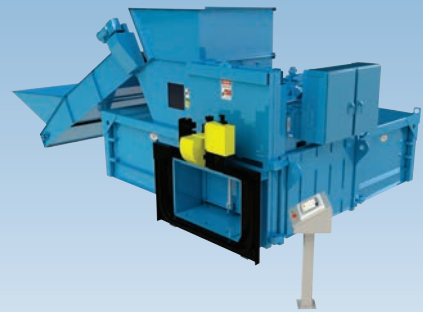
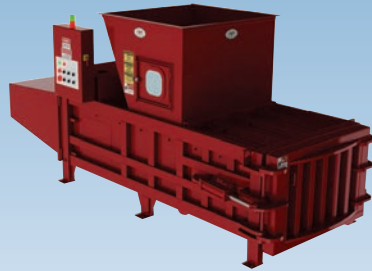
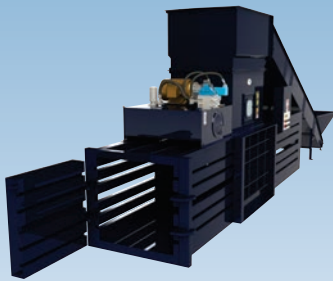

Leasing and Rental Programs Available

**Compactor Units can be custom designed
and factory installed to suit your special applications**

Cram-A-Lot® 1-2-3 Warranty

J.V. Manufacturing will furnish without charge:

- 1) All parts and labor expenses through the first year of ownership to remedy any faults proven to be the result of defective materials or workmanship.
- 2) All parts through the second year of ownership to remedy any faults proven to be the result of defective materials or workmanship.
- 3) All labor expenses through the third year of ownership to remedy any structural faults proven to be the result of defective materials or workmanship.

This warranty does not apply to any damage caused by negligence, misuse, modifications, alterations, or accidents by purchaser or third parties.
Refer to operation manual for specific warranty coverage.

CORPORATE OFFICE

P.O. Box 229
701 Butterfield Coach Road
Springdale, AR 72765

1-800-678-7320
479-751-7320
479-751-7774 (fax)

DISTRIBUTED BY:

www.cram-a-lot.com

05-13